

GeneDireX, Inc.

PRODUCT CATALOG

2023



Distributor in INDIA



Blook™ **GeneDireX®** **Simply®**

Benchtop Device

Protein Analysis

Plastic Consumables

Molecular Biology

Cell Culture

Custom Service

www.genedirex.com

INTRODUCTION

Three Major Brands Introduction



Small Bench-Top Devices

Blook series are designed bench-top devices to be space-saving, portable, easy to use and maintain, for gel visualization, and gel running. In addition, the multi-functional features allowing users to perform multiple tasks with a single equipment. This versatility provides users an economical choice, reducing the need to purchase multiple pieces of equipment.



Molecular Biology Reagents

Our molecular biology related product range are comprehensive, including high-quality nucleic acid purification kits, PCR and qPCR reagents, ladders, agarose, and safety stains for gel electrophoresis. With our commitment to quality and innovation, the products are processed with rigorous quality control to ensure consistent performance and reliability.



Cell Culture Media

Our cell culture media are carefully formulated to support the growth and maintenance of a wide variety of cell types. We offer a wide range of options for basal media, specialty media, supplements, and custom formulations, with finest materials and manufacturing processes to meet the specific needs of cell culture demands.

Global Quality Certifications for GeneDireX Products

We pleased and excited to announce that all of the products supplied by GeneDireX are in full compliance with the ISO 9001:2008 regulation and rules in 2012. In order to pursue better service and quality, GeneDireX completed ISO 13485 audit and received ISO13485:2012 certification in 2016.

The outstanding quality and performance of the GeneDireX, Inc. products have been substantiated by the publications in several leading international scientific journals over the past few years.



Production

At GeneDireX, Inc. We produce molecular biology reagents of highest quality. Our principal products include DNA and Protein Ladders, Gel Staining Reagents, Nucleic Acid Purification Systems, Molecular Biology Reagents, Lab Consumables, and Custom Services with exceptional stability at the ambient temperature.

Aliquoting

Precise aliquoting of our products is performed by skilled professionals in sterile conditions with the state-of-the-art equipment.

Packaging

Products are packaged into different vial sizes according to the customer's needs and convenience. Only high quality screw-cap tubes are used. Light sensitive reagents are packaged into amber vials to avoid damage.

Quality control

Every product goes through strict quality control procedures according to our ISO9001:2008-complined management systems in order to guarantee superior and consistent performance of our products.

Distribution

GeneDireX, Inc. has a growing worldwide network of dedicated distributors. Our distributors share our high standards in service and technical support.

Logistics

All GeneDireX, Inc. products are shipped at the ambient temperature – a very environment-friendly approach when compared to shipping on dry ice. Product orders are sent out within three to five business days, using the courier services most suitable for the client.

Environment and Transportation-Friendly

Ambient temperature stability not only eliminates the degradation concern during transportation but also reduces shipping and disposal costs of expensive insulation packagings, making the product friendly to the environment and user's budget.

CONTENTS

Benchtop Device 04

- BLook™ LED Transilluminator
- p*BLook™ LED Transilluminator
- μ*BLook™ LED Transilluminator
- gelBLook Electrophoresis System

Molecular Biology 08

- DNA Ladders
- DNA Gel Prep. & Stains
- RT, PCR & qPCR Reagents
- Nucleic Acid Purification System

Protein Analysis 54

- Protein Ladders
- Protein Gel Prep. & Stains
- Protein Labeling

Cell Culture 64

- Transfection Reagents
- Serum Reduced Formulation
- Specialty Media
- Basal Media
- Balanced Salt
- Antibiotics
- Cell Dissociation Reagents
- Supplements
- Water
- Human Recombinant Proteins

Plastic Consumables 86

- Centrifuge Tube
- PCR Tube
- Cryogenic Vial
- Cell Strainers
- Cell Culture Dish
- Glass Bottom Culture Dish
- Petri Dishes
- Cell Culture Flask
- ELISA Plate
- Cell Culture Plate
- Serological Pipet
- Filter
- Cell Scrape

Custom Service 112

- Dual Labeled Probe
- PRIME Gene Synthesis & Subcloning
- Custom Peptide Synthesis
- Custom Antibody Production Service
- Acro miR Vector System
- Acro miR mimics & inhibitor System
- Acro shRNA System
- Acro siRNA System

BENCHTOP DEVICE

LED Transilluminator

Product Name	Cat. No.	Size	Page
BLoK™ LED Transilluminator	BK001	1 Set	5
pBLoK™ LED Transilluminator	BK002	1 Set	6
μBLoK™ LED Transilluminator	BK003	1 Set	7
gelBLoK Electrophoresis System	BK008	1 Set	8

LED TRANSILLUMINATOR

BLoOK™

Cat No.	Size
BK001	1 each

Features

- Ergonomic fusion-Patented 4° ergonomic viewing angle ("Golden Angle").
- Optimized for use with the nucleic acid and protein fluorescent dyes.
- Blue light source good for 30,000 hours.
- No risk of UV damage for high quality work experience.
- Smart power-saving function – Automatic power shut-off option at 5 minutes.
- Gel-cutting knife – Cut out the target from the gel for further experiment.
- A mini darkroom for viewing gel or placing the photographic equipment.



Description

BLoOK™ is an extraordinary blue light LED transilluminator for the detection of nucleic acids or protein under non-UV conditions. The wavelength of the special blue LED lights is 470 nm (Fig 1), hence no damage to your nucleic acids or protein. Since UV is not used, there is no need for any special personal eye or skin protection. The blue LED lights are arranged under the viewing area (200 × 120 mm). An amber filter, on hinges, is lowered into position once your gel is mounted. The stained gel is now ready for observation. This instrument has a specially designed ergonomic 4° angle, so users can easily sit on a chair to see the experiment results. BLoOK™ is designed to inspect the gel after electrophoresis and stained with the Novel Juice, Novel Green, Novel Green *Plus*. Further, it is perfectly designed for OnePCR™, OnePCR™ HiFi, OnePCR™ HotStar, OnePCR™ Plus, OneMARK B, and OneMARK 100, which contains the fluorescent stain compatible with the blue light wavelength. However, BLoOK™ is not suitable for ethidium bromide staining.

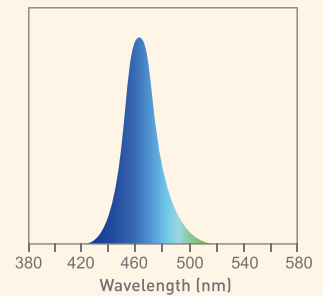

Fig.1. Emission spectrum for the BLoOK™ LED transilluminator



LED TRANSILLUMINATOR

pBLooK™

Cat No.	Color	Size	Cat No.	Color	Size
BA002-00BA	Black	1 each	BA002-00PL	Purple	1 each
BK002-00BG	Tiffany Blue	1 each	BK002-00RD	Red	1 each
BK002-00BU	Navy Blue	1 each	BK002-00WT	White	1 each
BK002-00PK	Pink	1 each	BK002-00YL	Yellow	1 each

Features

- PCR products for pre-checking before gel electrophoresis.
- Portable pocket size for checking PCR results without space constraints.

Description

pBLooK™ is a remarkable blue light LED transilluminator (Fig. 1) for nucleic acid detection with non-UV excitation conditions, hence, no damage to your DNA fragments. The excitation wavelength of the device is 470 nm, the best excitation condition suitable for most of all commercial fluorescent DNA staining dye. The special designed can inspect the amplification result in tube after PCR reaction. User can observe the signal simultaneously through the amber filter on cover frame. Accordingly, amaR OnePCR systems would be recommended to use from the initiation step, for the best detection condition.

* Please be noted that pBLooK™ is not suitable for ethidium bromide.

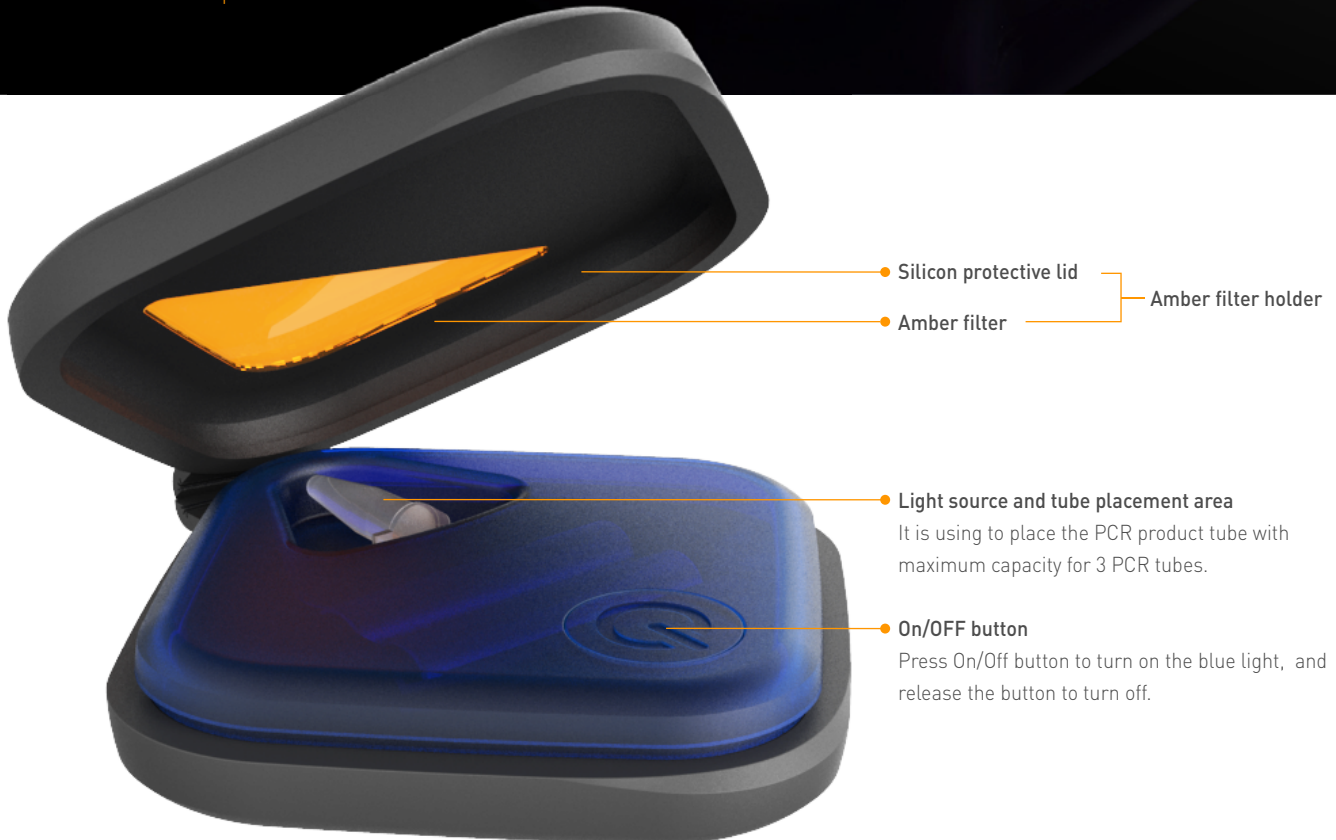

Fig. 1. pBLooK™ LED transilluminator.



LED TRANSILLUMINATOR

μ Blook™

Cat No.	Color	Size
BK003-000W	White	1 each
BK003-000B	Black	1 each

Features

- Optimize for use with the nucleic acid and protein fluorescent dyes.
- Blue light source is good for 30,000 hours.
- No risk of UV damage for high quality work experience.
- The rotating bracket is used for standing the instruments when switching down, easy to view the gel from the amber filter.

Description

μ Blook™ is a remarkable blue light LED transilluminator for the detection of nucleic acids or protein under non-UV excitation conditions. The wavelength of the special blue LED lights is 470 nm (Fig. 1), hence no damage to your nucleic acids or protein. Also, since UV is not used, there is no need for any special personal eye or skin protection. An amber filter, on hinges, is lowered into position once your gel is mounted. The stained gel is now ready for observation. μ Blook™ is designed to inspect the gel, stained with the Novel Juice, Novel Green, Novel Green *Plus* after electrophoresis. Further, it is perfectly designed for OnePCR™, OnePCR™ HiFi, OnePCR™ HotStar, which contains the fluorescent stain compatible with the blue light wavelength. However, μ Blook™ is not suitable for ethidium bromide.

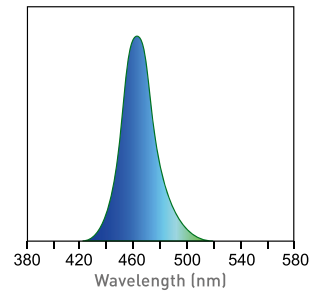

Fig.1. Emission spectrum for the μ Blook™ LED transilluminator



Amber filter

The upper panel is the amber filter used to observe the gel upon being lowered in position.

Tray

The tray is used to place the stained gel.

Auto switch button

Auto switch button is used for turn on/ off when the tray is put in or left the light source window.

Rotating bracket

The rotating bracket is used for standing the instruments when switching down

Power inlet

Power inlet is used for connecting the power cord.

Light source

The light source is located below and projects upward from the bottom. Please first lower the amber filter in position when in use for preventing the strong light from harming the eyes

Manual switch button

Manual switch button is used for switching on and off the power when press the button.

LED TRANSILLUMINATOR

gelBLook Electrophoresis System

Cat No.	Size
BK008-000B	1 each

Features

- Combining gel electrophoresis with blue LED light transilluminator.
- Amber filter with defogging design for real-time nucleic acid migration observation.
- Fulfilled gel cutting purposes upon electrophoresis tank (bottom is made of tempered glass).
- Integrated power supply for easily controlling the power of gel electrophoresis and light box.
- The visible area is 115 mm (L) x 95 mm (W), which supports loading on common gel sizes.
- Support two-stage voltage electrophoresis (50 V and 100 V).
- 50% buffer volume (160 mL) saved (Max volume: 320 mL).

Description

gelBLook is an instrument that combines the gel electrophoresis system with the blue LED transilluminator, designed for nucleic acid electrophoresis experiments. The special LED can emit blue light with a wavelength of 470 nm, which can reduce damage to the observed nucleic acid samples and ensure the quality of experiments and the safety of experimenters and the environment. The electrophoresis tank provides a visible area of 115 mm x 95 mm, which can fit all of the general gel sizes. The bottom of the electrophoresis tank is made of tempered glass, which can meet the needs of gel cutting. The gelBLook is suitable for commercially available safe fluorescent dyes with excitation wavelengths around 470 nm. Meanwhile, the defogging design on the amber filter enables the realtime observation of the gel electrophoresis for users to quickly interpret experimental results. This instrument is recommended for basic scientific research or nucleic acid investigation in other molecular biology-related fields.

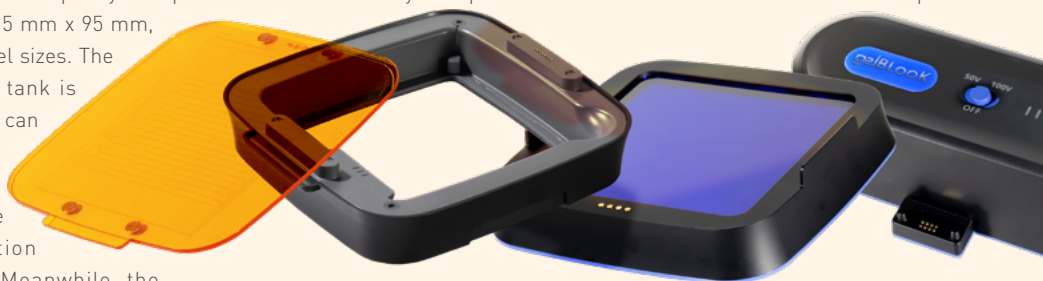

MOLECULAR BIOLOGY

DNA Ladders

Product Name	Cat. No.	Size	Page
100bp DNA Ladder RTU (Ready-to-Use)	DM001-R500 / SD001-R500	500 µl	11
100bp DNA Ladder H3 RTU (Ready-to-Use)	DM003-R500 / SD003-R500	500 µl	11
1Kb DNA Ladder RTU (Ready-to-Use)	DM010-R500 / SD010-R500	500 µl	12
Kplus DNA Ladder RTU (Ready-to-Use)	DM011-R500 / SD011-R500	500 µl	12
50bp DNA Ladder RTU (Ready-to-Use)	DM012-R500 / SD012-R500	500 µl	13
XLarge DNA Ladder RTU (Ready-to-Use)	DM013-R500 / SD013-R500	500 µl	13
OneMARK 100	DM101-0100 / SD101-0100	600 µl	14
OneMARK B	DM110-0100 / SD110-0100	600 µl	14

DNA Gel Prep. & Stains

Product Name	Cat. No.	Size	Page
Novel Juice (Supplied in 6X Loading Buffer)	LD001-1000 / SL001-1000	1 ml	15
Novel Green (10,000X)	LD002-0500 / SL002-0500	500 µl	16
Novel Green <i>Plus</i> (20,000X)	LD003-0500 / SL003-0500	500 µl	17
Novel Juice <i>PLUS</i>	SL007-1000	1 ml	18
Agarose-Molecular Biology Grade	MB755-0100 / SM755-0100	100 g	18
Agarose-Electrophoresis Grade	SA002-0100	100 g / 500 g	19

RT, PCR & qPCR Reagents

Product Name	Cat. No.	Size	Page
25 mM dNTP Mix, PCR Grade	DN100-1000 / ST100-1000	1 ml	20
2.5 mM dNTP Mix	DN025-1000 / ST025-1000	1 ml	20
10 mM dNTP Mix	DN021-1000 / ST021-1000	1 ml	21
100 mM dNTP Set	DN040-4000 / ST040-4000	1 ml x 4	21
100 mM dNTP Set	DN046-1000 / ST046-1000	250 µl x 4	21
<i>Taq</i> DNA Polymerase	MB101-0500 / SM101-0500	500 units	22
HotStar DNA Polymerase	MB102-0500 / SM102-0500	500 units	22
PCR SuperMix	MB200-0100 / SM200-0100	100 rxns	23
HotStar PCR Supermix	MB201-0100 / SM201-0100	100 rxns	23
OnePCR™	MB203-0100 / SM203-0100	100 rxns	24
OnePCR™ HiFi	MB205-0100 / SM205-0100	100 rxns	25
OnePCR™ HotStar	MB206-0100 / SM206-0100	100 rxns	26
OnePCR™ Plus	MB207-0100 / SM207-1000	100 rxns	27
2xPCR Mix	MB208-0100 / SM208-0100	100 rxns	28
BlooDireX PCR™ System	MB211-0100 / SM211-0100	100 rxns	28
One-Step RT-PCR System	MB300-0050 / SM300-0050	50 rxns	29
GScript RTase	MB303-0050 / SM303-0050	50 rxns	30
GScript First-Strand Synthesis Kit	MB305-0050 / SM305-0050	50 rxns	30
GScript One RT-PCR Kit	MB306-0050 / SM306-0050	50 rxns	30
QStrip One-Step RT-qPCR Mix	MB309-0008 / MB309-0048	8 rxns / 48 rxns	31
GScript <i>ULTRA</i> First-Strand Synthesis Kit (Random primer)	MB310-H100 / SM310-H100	100 rxns	31
GScript <i>ULTRA</i> First-Strand Synthesis Kit (Oligo-dT)	MB310-T100 / SM310-T100	100 rxns	32
GDP-HiFi DNA Polymerase	MB601-0100 / SM301-0100	100 units	32
Oligo (dT) ₂₀ Primer	MB701-0050 / SM701-0050	50 µM	33
Random Hexamers Primer	MB702-0100 / SM702-0100	50 µM	33
RiboIN RNase Inhibitor	RI001-2500 / SR001-2500	2500 U	33
amaR OnePCR™	SM213-0250	250 rxns	34

MOLECULAR BIOLOGY

RT, PCR & qPCR Reagents

Product Name	Cat. No.	Size	Page
amaR OnePCR™ HiFi	SM215-0250	250 rxns	35
amaR OnePCR™ HotStar	SM216-0250	250 rxns	36
One-Step qRT-PCR Kit	SM307-0100 / SM307-1000	100 rxns / 1000 rxns	38
SimplyGreen qPCR Master Mix, Rox	SQ101-0100	100 rxns	39
SimplyGreen qPCR Master Mix, Low Rox	SQ102-0100	100 rxns	39
SimplyGreen qPCR Master Mix, Rox-Free	SQ103-0100	100 rxns	40

Nucleic Acid Purification System

	Product Name	Cat. No.	Size	Page
RNA Isolation				
Reagent Based	Extract Reagent (Total RNA Isolation Reagent)	NA003-0100 / SN003-0100	100 ml	41
	PR Reagent (Plant Total RNA Isolation Reagent)	NA007-0100 / SN007-0100	100 ml	41
Spin Column Based	Total RNA Isolation Kit	NA017-0100 / SN017-0100	100 rxns	42
	Total RNA Isolation Kit (Plant)	NA020-0100 / SN020-0100	100 rxns	42
	Total RNA Isolation Kit (Tissue)	NA021-0100 / SN021-0100	100 rxns	43
DNA Isolation				
Reagent Based	Extract Reagent (Genomic DNA Isolation Reagent)	NA001-0100 / SN001-0100	100 ml	43
	PG Reagent (Plant Genomic DNA Isolation Reagent)	NA002-0100 / SN002-0100	100 ml	44
	Genomic DNA Isolation Reagent Kit (Blood/ Cultured Cell/ Tissue)	NA022-0100 / SN022-0100	100 rxns	44
Spin Column Based	Dual Genomic DNA Isolation Kit (Plant)	NA018-0100 / SN018-0100	100 rxns	45
	Genomic DNA Isolation Kit (Plant)	NA025-0100 / SN025-0100	100 rxns	45
	Dual Genomic DNA Isolation Kit (Tissue)	NA019-0100 / SN019-0100	100 rxns	46
	Genomic DNA Isolation Kit (Tissue)	NA026-0100 / SN026-0100	100 rxns	46
	Genomic DNA Isolation Kit (Paraffin-embedded tissue)	NA027-0100 / SN027-0100	100 rxns	47
	Dual Genomic DNA Isolation Kit (Blood/Cultured Cell/Fungus)	NA015-0100 / SN015-0100	100 rxns	47
	Genomic DNA Isolation Kit (Blood/Cultured Cell/ Fungus)	NA023-0100 / SN023-0100	100 rxns	48
	Genomic DNA Isolation Kit (Blood/ Cultured Cell)	NA028-0100 / SN028-0100	100 rxns	48
Magnetic Based	Mbead Buffy Coat Genomic DNA Kit	NA008-0100 / SN008-0100	100 rxns	49
	Mbead Tissue Genomic DNA Kit	NA009-0100 / SN009-0100	100 rxns	49
	Mbead Bacteria Genomic DNA Kit	NA010-0100 / SN010-0100	100 rxns	50
	Mbead Plant Genomic DNA Kit	NA012-0100 / SN012-0100	100 rxns	50
	Mbead Blood/Cell Genomic DNA Kit	NA013-0100 / SN013-0100	100 rxns	51
Virus Nucleic Acid Isolation				
Spin Column Based	Virus Nucleic Acid Isolation Kit	NA016-0100 / SN016-0100	100 rxns	51
Magnetic Based	Mbead Virus Genomic Nucleic Acid Kit	NA011-0100 / SN011-0100	100 rxns	52
Plasmid DNA Isolation				
Spin Column Based	Plasmid miniPREP Kit	NA005-0100 / SN005-0100	100 rxns	52
	Plasmid midiPREP Kit	NA205-0020 / SN205-0020	20 rxns	53
	Plasmid maxiPREP Kit	NA305-0010 / SN305-0010	10 rxns	53
DNA Purification				
Spin Column Based	PCR Clean-Up & Gel Extraction Kit	NA006-0100 / SN006-0100	100 rxns	54

DNA LADDERS

100bp DNA Ladder RTU

Cat No.	Size
DM001-R500	50 µg / 500 µl
SD001-R500	50 µg / 500 µl

Description

A unique combination of PCR products and a number of proprietary plasmids digested with appropriate restriction enzymes to yield 11 fragments, suitable for use as molecular weight standards for agarose gel electrophoresis. The DNA includes fragments ranging from 100-1,500 base pairs. The 500 and 1,500 base pair bands have increased intensity to serve as reference points. The approximate mass of DNA in each band is provided (0.5 µg a load) for approximating the mass of DNA in comparably intense samples of similar size.

Source

PCR products and double-stranded DNA digested with appropriate restriction enzymes, are phenol extracted and equilibrated to 10 mM Tris-HCl (pH 8.0) and 10mM EDTA.

Range: 100-1,500 base pairs **Number of Bands:** 11

Package: 50 µg / 500 µl **Concentration:** 100 µg / ml

Recommended Load: 5 µl / well

Containing orange G & xylene cyanol FF as tracking dyes.

Storage

Store at 25°C for 6 months

Store at 4°C for 12 months

Store at -20°C for 24 months

100bp DNA Ladder H3 RTU

Cat No.	Size
DM003-R500	54 µg / 500 µl
SD003-R500	54 µg / 500 µl

Description

A unique combination of PCR products and a number of proprietary plasmids digested with appropriate restriction enzymes to yield 12 fragments, suitable for use as molecular weight standards for agarose gel electrophoresis. The DNA includes fragments ranging from 100-3,000 base pairs. The 500 and 1,500 base pair bands have increased intensity to serve as reference points. The approximate mass of DNA in each band is provided (0.54 µg a load) for approximating the mass of DNA in comparably intense samples of similar size.

Source

PCR products and double-stranded DNA digested with appropriate restriction enzymes, are phenol extracted and equilibrated to 10 mM Tris-HCl (pH 8.0) and 10 mM EDTA.

Range: 100-3,000 base pairs **Number of Bands:** 12

Package: 54 µg / 500 µl **Concentration:** 108 µg / ml

Recommended Load: 5 µl / well

Containing orange G & xylene cyanol FF as tracking dyes.

Storage

Store at 25°C for 6 months

Store at 4°C for 12 months

Store at -20°C for 24 months

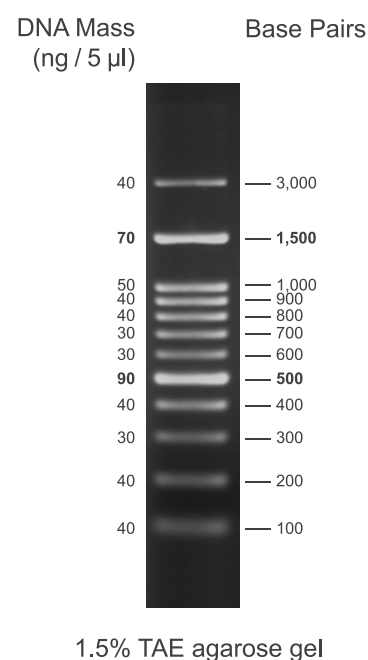
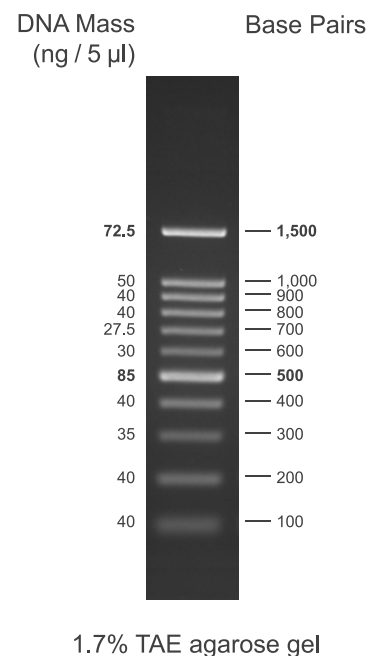

DNA LADDERS

1Kb DNA Ladder RTU

Cat No.	Size
DM010-R500	50 µg / 500 µl
SD010-R500	50 µg / 500 µl

Description

A unique combination of a number of proprietary plasmids digested with appropriate restriction enzymes and PCR products to yield 13 fragments, suitable for use as molecular weight standards for agarose gel electrophoresis. The DNA includes fragments ranging from 250- 10,000 base pairs. The 1K and 3K bands have increased intensity to serve as reference points. The approximate mass of DNA in each band is provided (0.5 µg a load) for approximating the mass of DNA in comparably intense samples of similar size.

Source

PCR products and double-stranded DNA digested with appropriate restriction enzymes, are phenol extracted and equilibrated to 10 mM Tris-HCl (pH 8.0) and 10 mM EDTA.

Range: 250-10,000 base pairs **Number of Bands:** 13

Package: 50 µg / 500 µl **Concentration:** 100 µg / ml

Recommended Load: 5 µl / well

Containing bromophenol blue & xylene cyanol FF as tracking dyes.

Storage

Store at 25°C for 6 months

Store at 4°C for 12 months

Store at -20°C for 24 months

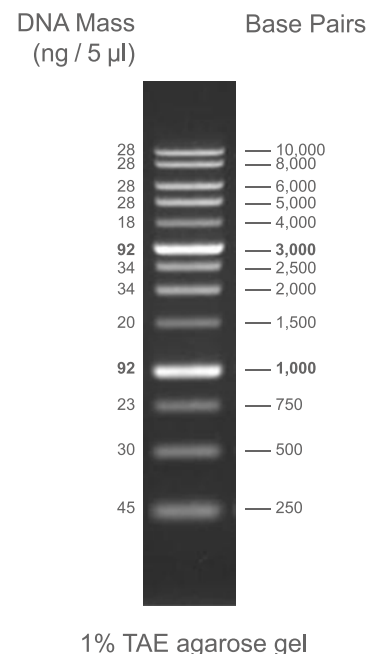

Kplus DNA Ladder RTU

Cat No.	Size
DM011-R500	86 µg / 500 µl
SD011-R500	86 µg / 500 µl

Description

A unique combination of a number of proprietary plasmids digested with appropriate restriction enzymes and PCR products to yield 19 fragments, suitable for use as molecular weight standards for agarose gel electrophoresis. The DNA includes fragments ranging from 100-10,000 base pairs. The 500, 1.5K and 3K bands have increased intensity to serve as reference points. The approximate mass of DNA in each band is provided (0.86 µg a load) for approximating the mass of DNA in comparably intense samples of similar size.

Source

PCR products and double-stranded DNA digested with appropriate restriction enzymes, are phenol extracted and equilibrated to 10 mM Tris-HCl (pH 8.0) and 10 mM EDTA.

Range: 100-10K base pairs **Number of Bands:** 19

Package: 86 µg / 500 µl **Concentration:** 172 µg / ml

Recommended Load: 5 µl / well

Containing orange G, xylene cyanol FF and bromophenol blue as tracking dyes

Storage

Store at 25°C for 6 months

Store at 4°C for 12 months

Store at -20°C for 24 months

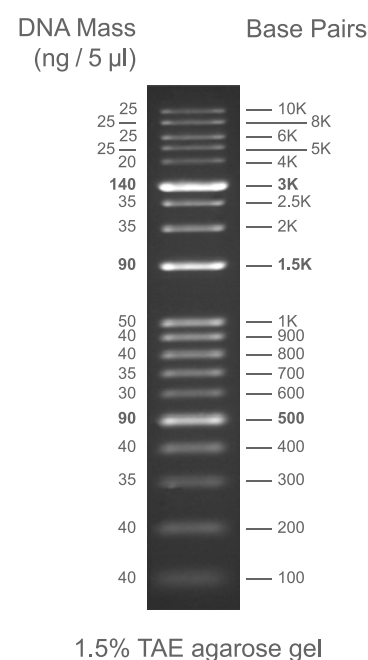

DNA LADDERS

50bp DNA Ladder RTU

Cat No.	Size
DM012-R500	56 µg / 500 µl
SD012-R500	56 µg / 500 µl

Description

A unique combination of PCR products and a number of proprietary plasmids digested with appropriate restriction enzymes to yield 17 fragments, suitable for use as molecular weight standards for agarose gel electrophoresis. The DNA includes fragments ranging from 50-1,500 base pairs. The 200, 500 and 1200 base pair bands have increased intensity to serve as reference points. The approximate mass of DNA in each band is provided (0.56 µg a load) for approximating the mass of DNA in comparably intense samples of similar size.

Source

PCR products and double-stranded DNA digested with appropriate restriction enzymes, are phenol extracted and equilibrated to 10 mM Tris-HCl (pH 8.0) and 10mM EDTA.

Range: 50-1,500 base pairs **Number of Bands:** 17

Package: 56 µg / 500 µl **Concentration:** 112 µg / ml

Recommended Load: 5 µl / well
Containing orange G as tracking dyes.

Storage

Store at 4°C for 12 months
Store at -20°C for 24 months

XLarge DNA Ladder RTU

Cat No.	Size
DM013-R500	52 µg / 500 µl
SD013-R500	52 µg / 500 µl

Description

A unique combination of a number of proprietary plasmids digested with appropriate restriction enzymes and PCR products to yield 14 fragments, suitable for use as molecular weight standards for agarose gel electrophoresis. The DNA includes fragments ranging from 250-25K base pairs. The 1K and 3K bands have increased intensity to serve as reference points. The approximate mass of DNA in each band is provided (0.52 µg a load) for approximating the mass of DNA in comparably intense samples of similar size.

Source

PCR products and double-stranded DNA digested with appropriate restriction enzymes, are phenol extracted and equilibrated to 10 mM Tris-HCl (pH 8.0) and 10mM EDTA.

Range: 250-25K base pairs **Number of Bands:** 14

Package: 52 µg / 500 µl **Concentration:** 104 µg / ml

Recommended Load: 5 µl / well
Containing bromophenol blue and xylene cyanol FF as tracking dyes.

Storage

Store at 25°C for 6 months
Store at 4°C for 12 months
Store at -20°C for 24 months

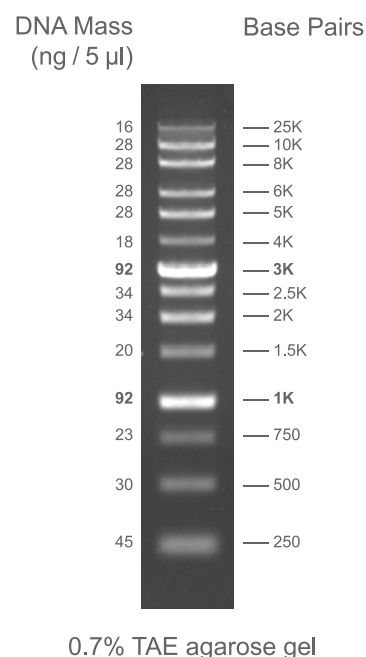
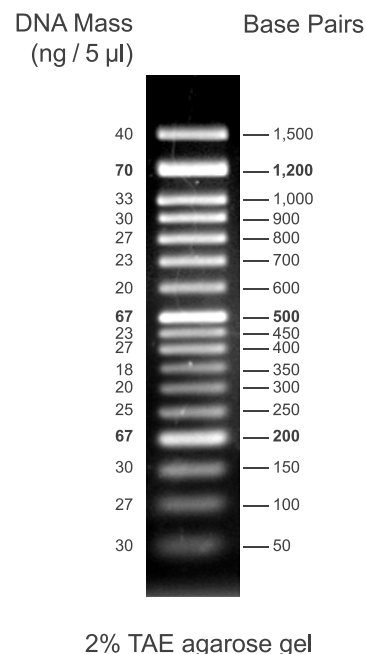

DNA LADDERS

OneMARK 100

Cat No.	Size
DM101-0100	600 µl
SD101-0100	600 µl

Description

OneMARK 100 with the Novel Green was designed to show virtually uniform spacing over a wide fragment range. The ladder is supplied in a ready-to-use format containing the fluorescent DNA stain and tracking dyes. High quantum yield and excellent stability make the fluorescence dye the ideal fluorophore for DNA staining applications and a superior replacement for the widely used dyes, ethidium bromide or SYBR® Green I. The OneMARK 100 with the Novel Green was optimized for direct loading onto unstained agarose gels. The ladders provide highest level of convenience during the routine handling and avoid commonly used gel staining procedures with ethidium bromide or SYBR® Green I. The OneMARK 100 includes fragments ranging from 100-3,000 base pairs. The 500 and 1,500 base pair bands have increased intensity to serve as reference points. The approximate mass of DNA in each band is provided (0.54 µg per loading) for approximating the mass of DNA in comparably intense samples of similar size.

Applications

- No-post-staining procession
- Direct loading onto your agarose gel for analysis

Source

PCR products and double-stranded DNA digested with appropriate restriction enzymes are phenol-extracted and equilibrated to 10 mM Tris-HCl (pH 8.0) and 1 mM EDTA.

Note: OneMARK 100 is light sensitive and should be stored and protected from light.

Range: 100-3,000 base pairs

Number of Bands: 12

Package: 54 µg / 600 µl

Concentration: 90 µg / ml

Recommended Load: 6 µl / well

Containing orange G & xylene cyanol FF as the tracking dyes.

Storage

Store at RT and 4°C up to 6 months.
Store at -20°C up to 1 year.

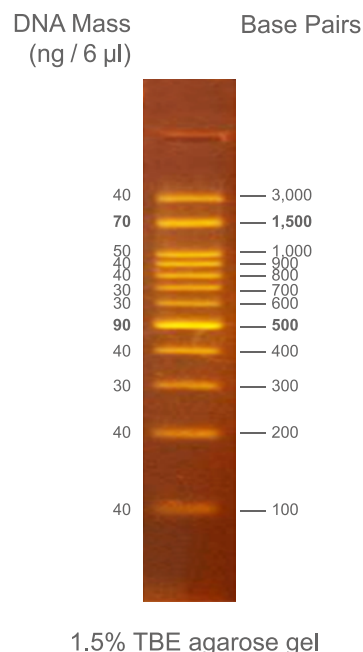

OneMARK B

Cat No.	Size
DM110-0100	600 µl
SD110-0100	600 µl

Description

OneMARK B with the Novel Green was designed to show virtually uniform spacing over a wide fragment range. The ladder is supplied in a ready-to-use format containing the fluorescent DNA stain and tracking dyes. High quantum yield and excellent stability make the fluorescence dye the ideal fluorophore for DNA staining applications and a superior replacement for the widely used dyes, ethidium bromide or SYBR® Green I. The OneMARK B with the Novel Green was optimized for direct loading onto unstained agarose gels. The ladders provide the highest level of convenience during the routine handling and avoid commonly used gel staining procedures with the ethidium bromide or SYBR® Green I. The OneMARK B includes fragments ranging from 250-10,000 base pairs. The 1K and 3K bands have increased intensity to serve as reference points. The approximate mass of DNA in each band is provided (0.5 µg per loading) for approximating the mass of DNA in comparably intense samples of similar size.

Applications

- No-post-staining procession
- Direct loading onto your agarose gel for analysis

Source

PCR products and double-stranded DNA digested with appropriate restriction enzymes are phenol-extracted and equilibrated to 10 mM Tris-HCl (pH 8.0) and 1 mM EDTA.

Note: OneMARK B is light sensitive and should be stored and protected from light.

Range: 250-10,000 base pairs

Number of Bands: 13

Package: 50 µg / 600 µl

Concentration: 83.3 µg / ml

Recommended Load: 6 µl / well

Containing bromophenol blue and xylene cyanol FF as the tracking dyes.

Storage

Store at RT and 4°C up to 6 months.
Store at -20°C up to 1 year.

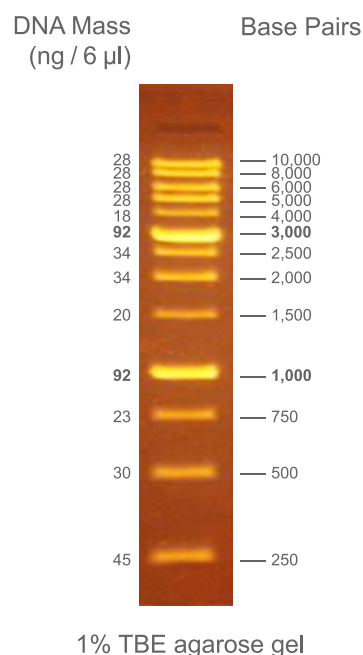

DNA GEL PREP. & STAINS

Novel Juice Supplied in 6X Loading Buffer

Cat No.	Size
LD001-1000	1 ml
SL001-1000	1 ml

Description

Novel Juice is a non-mutagenic fluorescent reagent that produces instant visualization of DNA bands upon Blue Light or UV illumination of agarose gels. Supplied in Simply's 6X DNA Loading Buffer, Novel Juice is used to prepare DNA markers and samples for loading on agarose or polyacrylamide gels. Novel Juice is the most sensitive stain available for detecting the double-stranded DNA (dsDNA). It contains three tracking dyes (Bromophenol Blue, Xylene Cyanol FF, and Orange G) for visually tracking the DNA migration during the electrophoresis process. It is ideal for the environment requiring a safe, non-hazardous alternative to Ethidium Bromide. Approximate fluorescence excitation/emission maxima: 300, 495/537 nm, bound to nucleic acid.

Fluorescence Ex/Em spectra of Novel Juice nucleic acid gel stain bound to DNA

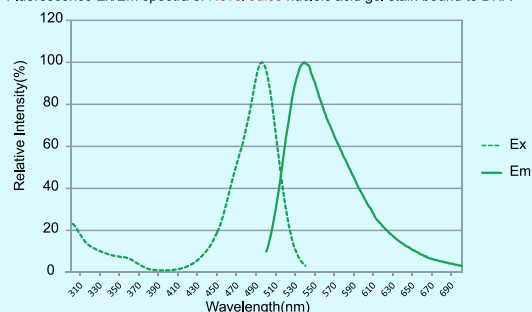

Tracking Dyes

Bromophenol Blue, Xylene Cyanol FF, and Orange G.

Quality Control

The quality of the Novel Juice is tested on a lot-to-lot basis to ensure consistent product quality.

Storage

Store at 4°C up to 12 months. For longer periods, store at -20°C. Novel Juice Dye is light sensitive and should be stored protected from light.

Recommendations for Loading

1. Vortex Novel Juice for 10 seconds prior to use.
2. Dilute 1 part Novel Juice with 5 parts DNA sample and mix.
Note: Novel Juice must be added to DNA markers in order to visualize the ladder bands simultaneously with the sample after electrophoresis.
3. Load sample and run according to standard procedures.
4. After the electrophoresis, remove gel and place on UV or a visible-light transilluminator to immediately visualize bands.
5. Gels can be post-stained with Ethidium Bromide if desired.

Novel Juice keeps your lab safe

Safe – Absence of mutagenity and low toxicity (LC>5000 mg/kg) as compared to Ethium Bromide.
 Low Environmental Impact – Compliance with the Clean Water Act standards. No water pollution concern.
 Sensitivity – High degree of sensitivity as Ethium Bromide.
 Convenience – Ready to Use; Same application procedures as the 6X Loading Dye.
 Speed – No de-staining requirement, low background value, and image displayed after coupling with the nucleic acid.
 Compatibility – Use the Blue Light or UV to detect the signal; Broad compatibility range.
 Economic – Non-hazardous product; No expenses required for the waste management.

Less DNA damage, improved cloning efficiency

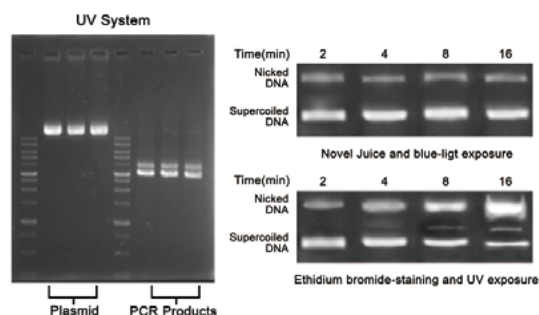

Slower migrating species are indicative of a linear or relaxed circular vector resulting from DNA nicking or strand breaks.

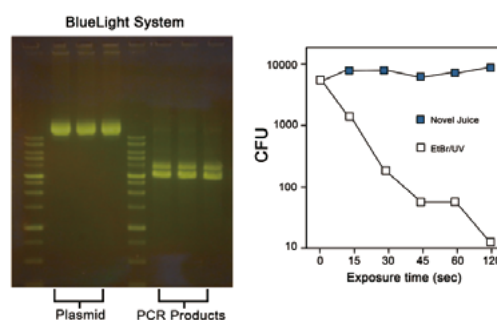

PCR fragments separated on agarose gels containing ethidium bromide or novel juice were exposed to UV or blue light for specific amounts of time, then used for subcloning. Even brief ethidium bromide/UV treatment yielded significantly fewer CFUs.

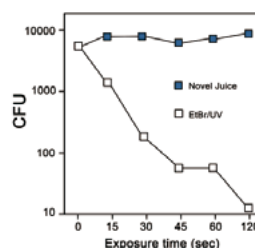

DNA GEL PREP. & STAINS

Novel Green (10,000X)

Cat No.	Size
LD002-0500	500 µl
SL002-0500	500 µl

Working Reagent Preparation: 1:10,000 dilution in TE, TAE or TBE buffer
 Storage: Stable for up to 1 year at -20°C.

Features

- Easy disposal.
- Simple to use.
- Ultra sensitive.
- Perfect compatibility with a blue light.
- Flexible for different procedures.

Description

The Novel Green provides an easy 2-step method to stain the DNA band from DNA electrophoresis. This unique reagent ensures the DNA to be stained with a high sensitivity and good quality. Novel Green is a next-generation DNA-binding dye ideal for use in quantitative real-time PCR (qPCR) and many other applications. We designed the dye by taking into consideration several essential dye properties relevant to PCR, including PCR inhibition, safety, and stability and fluorescence spectra of the dye. Ethidium bromide (EtBr), which presents sensitivity for detecting 1-5 ng double-stranded DNA (dsDNA) in the agarose gel analysis, has been the most common dye for nucleic acid gel staining. However, several drawbacks of EtBr have been understood, including that EtBr is a mutagen/carcinogen and presents a high risk of inducing cancer. Furthermore, the ultraviolet (UV) light used to illuminate EtBr-DNA compounds probably results in skin or eye damage to the user if misconduct. It's also noted that exposure to the UV light might cause chemical modifications of the DNA samples in the gel, such as the formation of TT dimmers, leading to challenge with the subsequent DNA manipulations. The Novel Green shows a high sensitivity bound with DNA (Fig.1), it also brings a more reliable and safer experience of use, since the stained gel can be visualized with the blue-light transilluminator, thus avoiding the risk of skin/eye damage as well as reducing the side effects of DNA modification caused by the UV light.

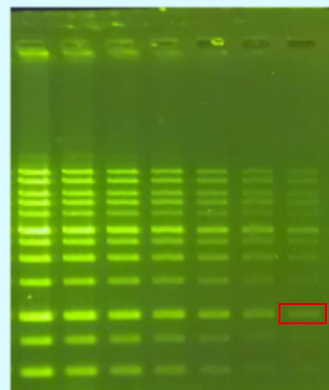

Fig. 1

Fig. 1 The 1Kb DNA Ladder (250-10,000 base pairs, Cat. No. DM010-R500, GeneDireX) was 2X serial diluted (from 2 to 128 dilution, and the concentration of the red mark is 0.72 ng/ 5ul) and loaded in the 1% agarose gel. After electrophoresis, the gel was stained with Novel Green for 10 minutes. The gel was observed the blue-light transilluminator.

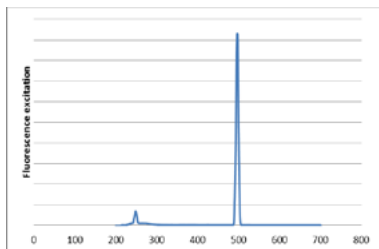

Fig. 2a Fluorescence excitation spectra of the Novel Green.

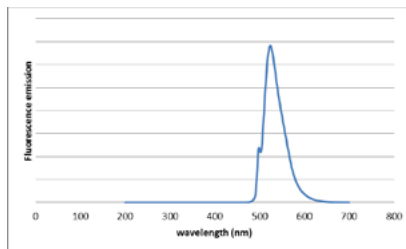

Fig. 2b Fluorescence emission spectra of the Novel Green bound to dsDNA.

Novel Green is excited at 497 nm but also shows a secondary excitation peak at 248 nm (Fig. 2a). After bound to DNA, the fluorescent emission of the Novel Green is centered at 524 nm (Fig. 2b). These spectral characteristics enable this fluorescent dye to be compatible with a wide variety of gel reading facilities.

Application

- DNA Staining.

Quality Control

The quality of the Novel Green is tested on a lot-to-lot basis to ensure consistent product quality.

Required Materials

- Electrophoresis equipments.
- DNA Markers (optional).
- Blue-light transilluminator.

Buffer Preparation

- 1 to 10,000 dilution in TE, TAE or TBE buffer, mix

Storage

Storage: Stable for up to 1 year at -20°C.

DNA GEL PREP. & STAINS

Novel Green Plus (20,000X)

Cat No.	Size
LD003-0500	500 µl
SL003-0500	500 µl

Features

- Easy disposal.
- Perfect compatibility with a blue light.
- Ultra sensitive.
- Simple to use.
- Flexible for different procedures.

Description

The Novel Green Plus provides an easy 2-step method to stain the DNA band from DNA electrophoresis. This unique reagent ensures the DNA to be stained with a high sensitivity and good quality. Novel Green Plus is a next-generation DNA-binding dye ideal for use in quantitative real-time PCR (qPCR) and many other applications. We designed the dye by taking into consideration several essential dye properties relevant to PCR, including PCR inhibition, safety, and stability and fluorescence spectra of the dye. Ethidium Bromide (EtBr), which presents sensitivity for detecting 1-5 ng doublestranded DNA (dsDNA) in the agarose gel analysis, has been the most common dye for nucleic acid gel staining. However, several drawbacks of EtBr have been understood, including that EtBr is a mutagen / carcinogen and presents a high risk of inducing cancer. Furthermore, the ultraviolet (UV) light used to illuminate EtBr-DNA compounds probably results in skin or eye damage to the user if misused. It's also noted that exposure to the UV light might cause chemical modifications of the DNA samples in the gel, such as the formation of TT dimers, leading to challenge with the subsequent DNA manipulations. The Novel Green Plus shows a high sensitivity bound with DNA (Fig.1), it also brings a more reliable and safer experience of use, since the stained gel can be visualized with the blue-light transilluminator, thus avoiding the risk of skin/eye damage as well as reducing the side effects of DNA modification caused by the UV light.

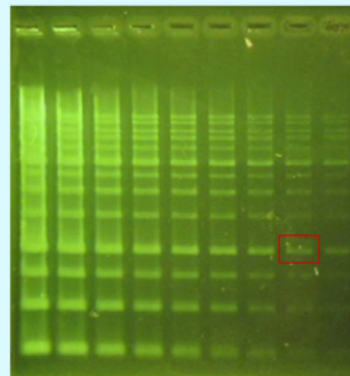

Fig.1a

Fig.1a The 1Kb DNA Ladder (250-10,000 base pairs, Cat. No. DM010-R500, GeneDireX) was 2X serial diluted (from 1 to 128 dilution), and the concentration of the red mark is 0.72 ng/5ul and loaded in the 1% agarose gel. After electrophoresis, the gel was stained with Novel Green Plus for 10 minutes. The gel was observed the blue-light transilluminator

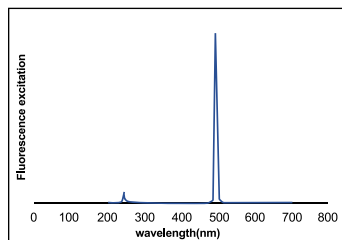

Fig. 2a Fluorescence excitation spectra of the Novel Green Plus

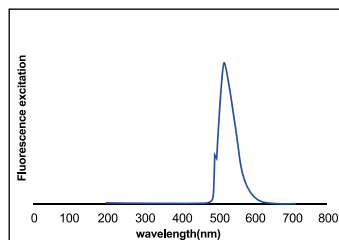

Fig. 2b Fluorescence emission spectra of the Novel Green Plus bound to dsDNA.

Novel Green Plus is excited at 497 nm but also shows a secondary excitation peak at 248 nm (Fig.2a).

After bound to DNA, the fluorescent emission of the Novel Green Plus is centered at 524 nm (Fig. 2b).

These spectral characteristics enable this fluorescent dye to be compatible with a wide variety of gel reading facilities.

Application

- DNA Staining.

Quality Control

The quality of the Novel Green Plus is tested on a lot-to-lot basis to ensure consistent product quality.

Required Materials

- Electrophoresis equipments.
- DNA Markers (optional).
- Blue-light transilluminator.

Buffer Preparation

- 1 to 20,000 dilution in TE, TAE or TBE buffer

Storage

Storage: Stable for up to 1 year at -20°C.

DNA GEL PREP. & STAINS

Novel Juice *PLUS*

Cat No.	Size
SL007-1000	1 ml

Features

- Sensitivity – High degree of sensitivity as Ethidium Bromide.
- Convenience – Ready to Use; Same application procedures as the 6X Loading Dye.
- Time efficiency – No de-staining requirement, low background value, and image displayed after coupling with the nucleic acid.
- Compatibility – Use the blue light or UV to detect the signal
- Economic – No expenses required for the waste management.

Description

Novel Juice *PLUS* is a fluorescent reagent that produces instant visualization of DNA bands upon blue light (e.g. BLook™, Cat. No. BK001) or UV illumination of agarose gels. Supplied in 6X DNA Loading Buffer, Novel Juice *PLUS* is used to prepare DNA markers or samples for loading on agarose or polyacrylamide gels. Novel Juice *PLUS* is the sensitive staining reagent available for detecting the double-stranded DNA (dsDNA). It contains three tracking dyes (bromophenol blue, xylene cyanol FF, and orange G) for visually tracking the DNA migration during the electrophoresis. It is ideal alternative to Ethidium Bromide (EtBr). Approximate fluorescence excitation / emission: 300, 495 / 537 nm, bound to nucleic acid.

Application

- DNA Sample Staining.

Tracking Dyes

- Bromophenol Blue, Xylene Cyanol FF, and Orange G

Quality Control

The quality of the Novel Juice *PLUS* Supplied in 6X Loading Buffer is tested on a lot-to-lot basis to ensure consistent product quality.

Required Materials

- Electrophoresis equipments.
- DNA Markers (optional).
- UV or blue light transilluminator.

Storage

For long periods, store at -20°C. When store at 4°C up to 12 months.

Note: Novel Juice *PLUS* Dye is light sensitive and should be stored protected from light.

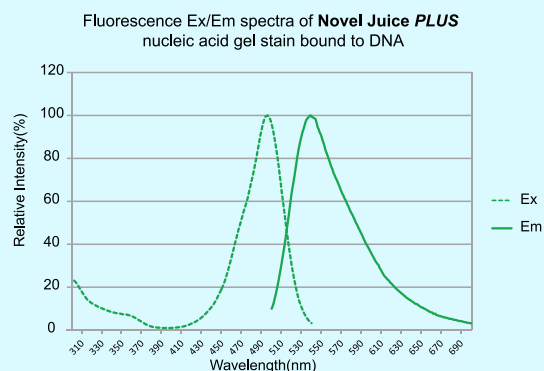

Agarose – Molecular Biology Grade

Cat No.	Size
MB755-0100	100 g
SM755-0100	100 g

Features

- DNase/RNase-free
- Gels as low as 0.5% are feasible
- Fast and convenient
- Safer and cleaner to use than conventional agarose powder
- Greater gel-to-gel consistency

Description

Agarose- Molecular Biology Grade (DNase/RNase free) are designed to provide a cleaner, safer, no-mess environment. Simply add powders to electrophoresis buffers, heat the solution, and then prepare your gel.

Application

- Ideal for separating nucleic acids of a wide range of sizes

Storage Conditions: Cool, dry place

Troubleshooting

Refer to the table below to troubleshooting problems that you may encounter when did culture cells with the supplement.

Problem	Cause	Solution
Hard to solidify	Incorrect concentration	Optimum concentration

Analytical Specifications:

Appearance	White powder
Gel strength of 1% (w/v) gel	>1280 g /cm ²
Melting point of 1.5% (w/v) gel	88-90°C
Gelling temperature	37-39°C
Sulfate	>0.1%
RNAase and RNAse	absent

DNA GEL PREP. & STAINS

Agarose - electrophoresis grade

Cat No.	Size
SA002-0100	100 g
SA002-0500	500 g

Store at ambient temperature

Features

- DNase/RNase-free
- Gels as low as 0.5% are feasible
- Fast and convenient
- Safer and cleaner to use than conventional agarose powder
- Greater gel-to-gel consistency

Description

Agarose - electrophoresis grade (DNase/RNase free) are designed to provide a cleaner, safer, no-mess environment. Simply add powders to electrophoresis buffers, heat the solution, and then prepare your gel.

Application

- PCR amplification

Storage Conditions: Cool, dry place

Analytical Specifications:

Appearance	White powder
Gel strength of 1% (w/v) gel	>1200 g /cm ²
Melting point of 1.5% (w/v) gel	87-89°C
Gelling temperature of 1.5% (w/v) gel	35-37°C

Troubleshooting

Refer to the table below to troubleshooting problems that you may encounter when did culture cells with the supplement.

Problem	Cause	Solution
Hard to solidify	Incorrect concentration	Optimum concentration

RT, PCR & QPCR REAGENTS

25 mM dNTP Mix, PCR Grade

Cat No.	Size
DN100-1000	1 ml
ST100-1000	1 ml

Features

- Compatible with almost DNA polymerases in a variety of applications
- ≥ 99% pure as determined by HPLC analysis
- Exceptional stability

Description

25 mM dNTP [2'-deoxynucleoside 5'-triphosphate] Mix consists of a solution of all four nucleotides (dATP, dCTP, dGTP, dTTP), each at a concentration of 25 mM. It is neutralized to pH 8.0 with NaOH, and supplied in purified water. 25 mM dNTP Mix is suitable for use in polymerase chain reaction (PCR), sequencing, fill-in, nick translation, cDNA synthesis, and TdT-tailing reactions.

Application

- PCR amplification

Quality Control

The quality of the 25 mM dNTP Mix, PCR Grade is tested on a lot-to-lot basis to ensure consistent product quality.

Required Materials

- PCR equipments
- PCR tube
- Primer
- PCR grade water

2.5 mM dNTP Mix, PCR Grade

Cat No.	Size
DN025-1000	1 ml
ST025-1000	1 ml

Features

- Compatible with almost DNA polymerases in a variety of applications.
- ≥ 99% pure as determined by HPLC analysis
- Exceptional stability

Description

2.5 mM dNTP [2'-deoxynucleoside 5'-triphosphate] Mix consists of a solution of all four nucleotides (dATP, dCTP, dGTP, dTTP), each at a concentration of 2.5 mM. It is neutralized to pH 8.0 with NaOH, and supplied in purified water. 2.5 mM dNTP Mix is suitable for use in polymerase chain reaction (PCR), sequencing, fill-in, nick translation, cDNA synthesis, and TdT-tailing reactions.

Application

- PCR amplification

Quality Control

The quality of the 2.5 mM dNTP Mix, PCR Grade is tested on a lot-to-lot basis to ensure consistent product quality.

Required Materials

- PCR equipments
- PCR tube
- Primer
- PCR grade water

Protocol

Add recommended volume of dNTP solution into PCR reaction. The following in the below table is recommended:
20 µl Final Reaction Volume

Final dNTP Concentration	dNTP Volume
0.2 mM	0.16 µl
0.5 mM	0.4 µl
1.0 mM	0.8 µl
1.5 mM	1.2 µl

25 µl Final Reaction Volume

Final dNTP Concentration	dNTP Volume
0.2 mM	0.2 µl
0.5 mM	0.5 µl
1.0 mM	1 µl
1.5 mM	1.5 µl

50 µl Final Reaction Volume

Final dNTP Concentration	dNTP Volume
0.2 mM	0.4 µl
0.5 mM	1 µl
1.0 mM	2 µl
1.5 mM	3 µl

Protocol

Add recommended volume of dNTP solution into PCR reaction. The following in the below table is recommended:
20 µl Final Reaction Volume

Final dNTP Concentration	The Volume of dNTP Mixture	Reactions Per Kit
0.2 mM	1.6 µl	625
0.5 mM	4 µl	250
1.0 mM	8 µl	125
1.5 mM	12 µl	83

25 µl Final Reaction Volume

Final dNTP Concentration	The Volume of dNTP Mixture	Reactions Per Kit
0.2 mM	2 µl	500
0.5 mM	5 µl	200
1.0 mM	10 µl	100
1.5 mM	15 µl	66

50 µl Final Reaction Volume

Final dNTP Concentration	The Volume of dNTP Mixture	Reactions Per Kit
0.2 mM	4 µl	250
0.5 mM	10 µl	100
1.0 mM	20 µl	50
1.5 mM	30 µl	33.3

RT, PCR & QPCR REAGENTS

10 mM dNTP Mix

Cat No.	Size
DN021-1000	1 ml
ST021-1000	1 ml

Description

10 mM dNTP (2'-deoxynucleoside 5'-triphosphate) Mix consists of all four nucleotides (dATP, dCTP, dGTP, dTTP), each at a concentration of 10 mM, in a solution of 0.6 mM Tris-HCl (pH 7.5). The 10 mM dNTP Mix is suitable for use in polymerase chain reaction (PCR), sequencing, fill-in, nick translation, cDNA synthesis, and TdT-tailing reactions.

Quality Control

The quality of the 10 mM dNTP Mix is tested on a lot-to-lot basis to ensure consistent product quality.

Required Materials

- PCR equipments
- PCR tube
- Primer
- PCR grade water

100 mM dNTP Set

Cat No.	Size
DN040-4000	4 x 1 ml
DN046-1000	4 x 250 µl
ST040-4000	4 x 1 ml
ST046-1000	4 x 250 µl

Features

- Compatible with almost DNA polymerases in a variety of applications.
- ≥ 99% pure as determined by HPLC analysis
- Exceptional stability

Description

100 mM dNTP (2'-deoxynucleoside 5'-triphosphate) Set consists of all four deoxynucleotides (dATP, dCTP, dGTP, dTTP), each at a concentration of 100 mM. The deoxynucleotides are suitable for use in polymerase chain reaction (PCR), sequencing, fill-in, nick translation, cDNA synthesis, and TdT tailing reactions. The product is supplied as ready-to-use solutions.

Quality Control

The quality of the 100 mM dNTP Set is tested on a lot-to-lot basis to ensure consistent product quality.

Required Materials

- PCR equipments
- PCR tube
- Primer
- PCR grade water

Buffer Preparation

TE Buffer (Tris-EDTA, pH8.0): 10 mM Tris-HCl, pH 8.0 with 0.1mM EDTA

Volumes and Concentrations

20 µl Final Reaction Volume

Final dNTP Conc	dNTP Volume	Reactions per Kit
0.2 mM	0.4 µl	2500
0.5 mM	1 µl	1000
1.0 mM	2 µl	500
1.5 mM	3 µl	333

25 µl Final Reaction Volume

Final dNTP Conc	dNTP Volume	Reactions per Kit
0.2 mM	0.5 µl	2000
0.5 mM	1.25 µl	800
1.0 mM	2.5 µl	400
1.5 mM	3.75 µl	266

Protocol

Add recommended volume of dNTP solution into PCR reaction. The following in the below table is recommended:

20 µl Final Reaction Volume

Final dNTP Concentration	The Volume of dNTP Mixture
0.2 mM	0.16 µl
0.5 mM	0.4 µl
1.0 mM	0.8 µl
1.5 mM	1.2 µl

25 µl Final Reaction Volume

Final dNTP Concentration	The Volume of dNTP Mixture
0.2 mM	0.2 µl
0.5 mM	0.5 µl
1.0 mM	1 µl
1.5 mM	1.5 µl

50 µl Final Reaction Volume

Final dNTP Concentration	The Volume of dNTP Mixture
0.2 mM	0.4 µl
0.5 mM	1 µl
1.0 mM	2 µl
1.5 mM	3 µl

RT, PCR & QPCR REAGENTS

Taq DNA Polymerase

Cat No.	Size
MB101-0500	500 units
SM101-0500	500 units

Features

- Ideal for routine PCR applications.
- Kit includes optimized reagents and enables flexible experiments.

Description

Taq DNA Polymerase is a simple, specificity PCR reaction mixture. Simply add primers, template, dNTPs, and PCR grade water, the reagent will execute primer extensions and other molecular biology applications. *Taq* DNA Polymerase contains two components, include the *Taq* DNA polymerase and 10X PCR buffer. The *Taq* DNA Polymerase is purified from *E. coli.*, expressing a *Thermus aquaticus* DNA polymerase gene. This enzyme has a 5' → 3' DNA polymerase and a 5' → 3' exonuclease activity but lacks a 3' → 5' exonuclease activity. The enzyme consists of a single polypeptide with a molecular weight of approximately 94 kilo Dalton. *Taq* DNA polymerase is heat-stable and will synthesize DNA at elevated temperatures from single-stranded templates in the presence of a primer. The *Taq* DNA Polymerase is recommended for use in routine PCR reactions. The 10X PCR buffer is optimized for high specificity and guarantees minimal by product formation. Usually 1-1.5 unit of *Taq* DNA polymerase is used in 50 µl of reaction mix. Higher *Taq* DNA polymerase concentrations may cause synthesis of nonspecific products. However, if inhibitors exist in the reaction mixture (e.g., if the template DNA used is not highly purified), higher amounts of *Taq* DNA polymerase (2-3 units) may be necessary to obtain a better yield of amplification products.

Kit contents

Contents	Size
<i>Taq</i> DNA Polymerase (5 units/µl)	500 units X 1 vial
10X PCR buffer	1.25 mL X 2 vials

Applications

- Microarray analysis.
- PCR Amplification
- Colony PCR.

Quality Control

The quality of the *Taq* DNA Polymerase is tested on a lot-to-lot basis to ensure consistent product quality

Required Materials

- 10 mM dNTP mix
- PCR grade water
- PCR microcentrifuge tubes
- PCR thermal cycler

Storage Buffer

The enzyme is supplied in a storage buffer consisting of 50 mM Tris-HCl (pH 8.0), 100 mM NaCl, 0.1 mM EDTA, 5 mM DTT, 50% glycerol and 1.0% Triton®X-100.

Unit Definition

One unit is defined as the enzyme catalyzes the incorporation of 10 nanomoles of deoxyribonucleotides into a polynucleotide fraction in 30 minutes at 70°C.

HotStar DNA Polymerase

Cat No.	Size
MB102-0500	500 units
SM102-0500	500 units

Feature

- Ideal for high specificity PCR applications.

Description

The HotStar DNA Polymerase is a recombinant thermo-stable *Taq* DNA polymerase with an aptamer-based inhibitor designed for preventing non-specific DNA amplification in PCR reactions. This product contains two components, include HotStar DNA Polymerase and 10X HS PCR buffer. The activity of polymerase is inactivated by a reversible binding of the aptamer to the polymerase at temperatures below 45°C. The aptamer-based inhibition does not require an additional heat activation step required by antibody-based or chemically modified hot start polymerases. The aptamer inhibitor releases the enzyme during normal PCR cycling, allowing reactions to be set up at room temperature. The HotStar DNA Polymerase is suitable for high PCR specificity and yield. The HotStar DNA Polymerase is purified from an *E. coli.* strain, expressing a *Thermus aquaticus* DNA polymerase gene. This enzyme possesses a 5' → 3' polymerase activity and a 5' → 3' exonuclease activity (but lacks a 3' → 5' exonuclease activity), and a terminal transferase activity that adds a single deoxyadenosine (dA) to the 3' ends of PCR products. The HotStar DNA Polymerase can be used for high-specificity PCR, multiplex PCR, routine PCR, and generation of PCR products for TA cloning. 1.25-2.5 units of HotStar DNA Polymerase is recommended for use in 50 µl of PCR reactions.

Applications

- Microarray Analysis.
- Colony PCR.
- PCR Amplification

Required Materials

- 10 mM dNTP mix
- PCR grade water
- PCR microcentrifuge tubes
- PCR thermal cycler

Quality Control

The quality of the HotStar DNA Polymerase is tested on a lot-to-lot basis to ensure consistent product quality

Storage Buffer

The enzyme is supplied in a storage buffer consisting of 50 mM Tris-HCl (pH 8.0), 50 mM KCl, 0.1 mM EDTA, 1 mM DTT, stabilizer and 50% glycerol.

RT, PCR & QPCR REAGENTS

PCR SuperMix

Cat No.	Size
MB200-0100	100 Reactions
SM200-0100	100 Reactions

Description

PCR SuperMix provides qualified reagents for the amplification of nucleic acid templates by the polymerase chain reaction (PCR). PCR SuperMix contains Mg^{++} , dNTPs, and recombinant *Taq* DNA Polymerase at concentrations sufficient to allow amplification during PCR. PCR SuperMix is supplied at 1.1X concentration to allow approximately 10% of the final reaction volume to be used for the addition of primer and template solutions. Reagents sufficient for 100 amplification reactions of 50 μ l each are provided. PCR SuperMix may be stored at either $-20^{\circ}C$ or $4^{\circ}C$. Storage at $4^{\circ}C$ avoids the necessity of thawing the mix before assembling the PCR. No detectable reduction of PCR performance or enzyme activity is observed after storage of PCR SuperMix for 12 months at $4^{\circ}C$. Repeated freeze-thaw cycles do not reduce performance or activity.

Components

22 mM Tris-HCl (pH 8.4), 55 mM KCl, 1.65 mM $MgCl_2$, 220 μ M dGTP, 220 μ M dATP, 220 μ M dTTP, 220 μ M dCTP, and stabilizers. This product is distributed for laboratory research only. CAUTION: Not for diagnostic use. The safety and efficacy of this product in diagnostic or other clinical uses has not been established.

Quality Control

PCR SuperMix is evaluated in a DNA polymerization activity assay that measures the percent of *Taq* DNA polymerase inhibition versus an uninhibited control. A functional assay is also performed. Components of PCR SuperMix are tested for the absence of DNase, RNase and exonuclease activities. Recombinant *Taq* DNA polymerase is tested for the absence of exonuclease, and double- and single-stranded endonuclease activities. The enzyme is \rightarrow 90% homogeneous as determined by SDSpolyacrylamide gel electrophoresis.

Guidelines and Recommendations

Since PCR is a powerful technique capable of amplifying trace amounts of DNA, all appropriate precautions should be taken to avoid crosscontamination. Ideally, amplification reactions should be assembled in a DNA-free environment. Use of aerosol-resistant barrier tips is recommended. Take care to avoid contamination of PCR SuperMix with the primers or template DNA used in individual reactions. PCR products should be analyzed in an area separate from the reaction assembly area. A standard 50 μ l reaction uses 45 μ l of PCR SuperMix and 5 μ l of primer and template solutions. For the primer sets used in the development of PCR SuperMix, no decrease in product yield was observed if the amount of template and primer solution added is between a fraction of a microliter and 20 μ l. Lower yield occurs as the Mg^{++} concentration drops to a suboptimal level. If the final Mg^{++} concentration is adjusted to 1.5 mM, the volume of primer and template solution that can be added to 45 μ l of PCR SuperMix can exceed 50 μ l.

HotStar PCR SuperMix

Cat No.	Size
MB201-0100	100 Reactions (2 \times 1.25 ml)
SM201-0100	100 Reactions (2 \times 1.25 ml)

Description

HotStar PCR SuperMix provides qualified reagents for the amplification of nucleic acid templates by polymerase chain reaction (PCR). The mixture contains anti-*Taq* DNA polymerase antibody, Mg^{++} , dNTPs, and recombinant *Taq* DNA polymerase at concentrations sufficient to allow amplification during PCR. HotStar PCR SuperMix is supplied at 2X concentration to allow approximately 50% of the final reaction volume to be used for the addition of primer and template solutions. Reagents sufficient for 100 amplification reactions of 50 μ l each are provided. Anti-*Taq* DNA polymerase antibody inhibits polymerase activity providing an automatic hot start and permits ambient temperature setup. Antibody-mediated hot starts improve PCR specificity and yield. Due to specific binding of the antibody, HotStar PCR SuperMix is present in an inactive form and is reactivated after a denaturation step in PCR cycling at $94^{\circ}C$. HotStar PCR SuperMix may be stored at either $-20^{\circ}C$ or $4^{\circ}C$. Storage at $4^{\circ}C$ avoids the necessity of thawing the mix before assembling the PCR. Repeated freeze-thaw cycles might reduce performance or activity.

Quality Control

HotStar PCR SuperMix is evaluated in a DNA polymerization activity assay that measures the percent of *Taq* DNA polymerase inhibition versus an uninhibited control. A functional assay is also performed. Components of HotStar PCR SuperMix are tested for the absence of DNase, RNase and exonuclease activities. Recombinant *Taq* DNA polymerase is tested for the absence of exonuclease, and double- and single-stranded endonuclease activities.

Guidelines and Recommendations

Since PCR is a powerful technique capable of amplifying trace amounts of DNA, all appropriate precautions should be taken to avoid cross contamination. Ideally, amplification reactions should be assembled in a DNA-free environment. Use of aerosol-resistant barrier tips is recommended. Take care to avoid contamination of HotStar PCR SuperMix with the primers or template DNA used in individual reactions. PCR products should be analyzed in an area separate from the reaction assembly area. A standard 50 μ l reaction uses 25 μ l of HotStar PCR SuperMix and 25 μ l of primer and template solutions. For the primer sets used in the development of HotStar PCR SuperMix, no decrease in product yield was observed if the amount of template and primer solution added is between a fraction of a microliter and 25 μ l. Lower yield occurs as the Mg^{++} concentration drops to a suboptimal level. If the final Mg^{++} concentration is adjusted to 1.5 mM, the volume of primer and template solution that can be added to 25 μ l of HotStar PCR SuperMix can exceed 50 μ l.

RT, PCR & QPCR REAGENTS

OnePCR™

Cat No.	Size
MB203-0100	100 Reactions (2 X 1.25 ml)
SM203-0100	100 Reactions (2 X 1.25 ml)

Features

- No post-staining processing of DNA required.
- Direct loading onto your agarose gel for analysis.
- Speed – No destaining requirement.
- No need to prepare PCR Reagents.
- Sensitivity – High degree of sensitivity as the ethium bromide.
- Compatibility – Use the blue light or UV to detect the signal.

Description

OnePCR™ is a ready-to-use PCR reaction mixture. Simply add primers, template, and water, the reagent will execute primer extensions and other molecular biology applications. OnePCR™ is a pre-mixed solution containing *Taq* DNA polymerase, PCR Buffer, dNTP, gel loading dyes, and fluorescence dye. OnePCR™ which contains the *Taq* DNA polymerase, is purified from the *E. coli*, and expressing the *Thermus aquaticus* DNA polymerase gene. This enzyme has a 5' → 3' DNA polymerase and the 5' → 3' exonuclease activity but lacks the 3' → 5' exonuclease activity. OnePCR™, which contains the fluorescence dye, is directly detected on BLook™ LED transilluminator (Cat. No. BK001) or UV epi-illuminator after the DNA electrophoresis. OnePCR™ mixture is supplied at the 2X concentration to allow approximately 50% of the final reaction volume to be used for the addition of primer and template solutions. Reagents are provided with the sufficient amplification reactions of 50 µl each.

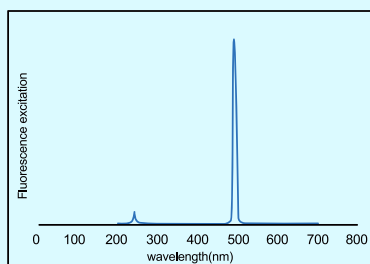

Fig. 1a. Fluorescence excitation spectra of the fluorescence dye

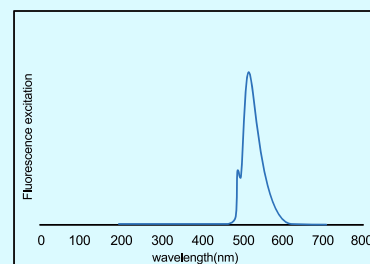

Fig. 1b Fluorescence emission spectra of the fluorescence dye

Tracking Dyes

- Bromophenol Blue, Xylene Cyanol FF.

Protocol

Standard PCR with OnePCR™:

- For each 50 µl reaction, assemble the following components in a 0.2 ml PCR tube on ice just prior to use:

Component	Volume [µl]
OnePCR™	25
Forward primer, 5~10 µM	1
Reverse primer, 5~10 µM	1
DNA template	1
Add ddH ₂ O to	50

- Mix gently. If necessary, centrifuge briefly. Cap tubes and place in the thermal cycler.
- Process in the thermal cycler for 25~35 cycles as follows:

Initial Denaturation	2~5 minutes at 94°C	} 30 cycles
Denaturation	20~40 seconds at 94°C	
Annealing	1 minute at the proper annealing temperature	
Extension	2 mins at 72°C	
Final extension	5 mins at 72°C	

Note: Optimal conditions for amplification will vary depending on the primers and thermal cycler used. It may be necessary to optimize the system for individual primers, template, and thermal cycler.

- After the PCR reaction, DNA electrophoresis will detect the PCR product.

- Use the UV or blue-light transilluminator or UV epi-illuminator to photograph the gel.

Note: When the DNA concentration is less than 4pg, it may cause the migratory shift when performing the electrophoresis. To remedy this observation, we recommend to conduct the following steps (please refer to the experimental procedures), or use the PCR Clean-Up & Gel Extraction Kit (see Cat. No. NA006-0100) to remove the fluorescence dye prior to post-staining with the Novel Green (Cat. No. LD002-0500) or Novel Green *plus* (Cat. No. LD003-0500) again for restoring the DNA molecular weight in the original position.

Removal of Fluorescence Dye

- Immerse the PCR product containing the fluorescence dye into the 100 mM NaCl and add 2.5 volumes of absolute or 95% ethanol.
- Incubate on ice for 20 minutes.
- Centrifuge the mixture at 4°C for at least 10 minutes.
- Remove the suspension of ethanol and wash the pellet with 1ml of 70% ethanol.
- Dry the residual ethanol and resuspend the double-stranded DNA in the TE buffer.

Storage

Store at RT up to 3 month.

Store at 4°C up to 6 month.

Store at -20°C up to 1 year.

Shipping Temperature: 4°C

Note: OnePCR™ is light sensitive and should be stored and protected from light.

RT, PCR & QPCR REAGENTS

OnePCR™ HiFi

Cat No.	Size
MB205-0100	100 Reactions (2 X 1.25 ml)
SM205-0100	100 Reactions (2 X 1.25 ml)

Features

- No post-staining procession.
- Direct loading onto your agarose gel for analysis.
- Time Efficiency- No destaining requirement.
- Effective for the amplification of GC-rich targets.
- No need to prepare PCR reagents.
- Sensitivity- High degree of sensitivity as the ethium bromide.
- Compatibility - Use the Blue Light or UV to detect the signal.
- Exhibits strong 3'→5' exonuclease activity.

Description

OnePCR™ HiFi is a ready-to-use PCR reaction mixture. Simply adding primers and template, the reagent will execute primer extensions and other molecular biology applications. OnePCR™ HiFi is a pre-mixed solution containing GDP-HiFi DNA polymerase, PCR buffer, dNTPs, gel loading dyes, enhancer, and fluorescence dye. It contains the fluorescence dye, which is directly detected on the blue-light transilluminator or UV epi-illuminator after the DNA electrophoresis. The OnePCR™ HiFi mixture is supplied at the 2X concentration to allow approximately 50% of the final reaction volume to be used for the addition of the primer and template solutions. Reagents are provided with sufficient amplification reactions of 50 µl each. OnePCR™ HiFi exhibits strong proof-reading activity. The GDP-HiFi DNA polymerase exhibits excellent processivity and elongation capability. The elongation rate of this enzyme is approximately 2 times higher than that of *Taq* DNA polymerase. OnePCR™ HiFi has an extension rate of 106 to 138 nucleotides per second. OnePCR™ HiFi produces blunt end PCR products.

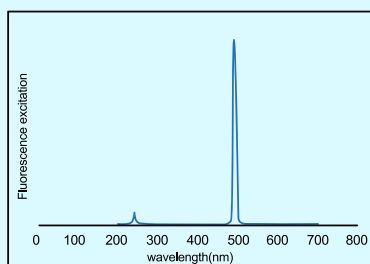

Fig. 1a. Fluorescence excitation spectra of the fluorescence dye

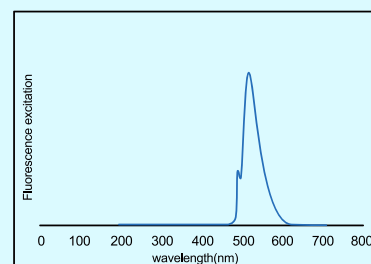

Fig. 1b Fluorescence emission spectra of the fluorescence dye

Tracking Dyes

- Bromophenol Blue, Xylene Cyanol FF.

Protocol

Standard PCR with OnePCR™ HiFi:

1. For each 50 µl reaction, assemble the following components in a 0.2 ml PCR tube on ice just prior to use:

Component	Volume (µl)
OnePCR™ HiFi	25
Forward primer, 5~10 µM	Variable
Reverse primer, 5~10 µM	Variable
DNA template	Variable
Total	50

2. Mix gently. If necessary, centrifuge briefly. Cap tubes and place in the thermal cycler.

3. Process in the thermal cycler for 25-35 cycles as follows:

Initial Denaturation	2~5 minutes at 94°C	} 30 cycles
Denaturation	20~40 seconds at 94°C	
Annealing	1 minute at the proper annealing temperature	
Extension	2 mins at 72°C	
Final extension	5 mins at 72°C	

Note: Optimal conditions for amplification will vary depending on the primers and thermal cycler used. It may be necessary to optimize the system for individual primers, template, and thermal cycler.

4. After the PCR reaction, DNA electrophoresis will detect the PCR product.

5. Use the UV or blue-light transilluminator or UV epi-illuminator to photograph the gel.

Note: When the DNA concentration is less than 4pg, it may cause the migratory shift when performing the electrophoresis. To remedy this observation, we recommend to conduct the following steps (please refer to the experimental procedures), or use the PCR Clean-Up & Gel Extraction Kit [see Cat. No. NA006-0100] to remove the fluorescence dye prior to post-staining with the Novel Green (Cat. No. LD002-0500) or Novel Green *plus* (Cat. No. LD003-0500) again for restoring the DNA molecular weight in the original position.

Removal of Fluorescence Dye

1. Immerse the PCR product containing the fluorescence dye into the 100 mM NaCl and add 2.5 volumes of absolute or 95% ethanol.
2. Incubate on ice for 20 minutes.
3. Centrifuge the mixture at 4°C for at least 10 minutes.
4. Remove the suspension of ethanol and wash the pellet with 1ml of 70% ethanol.
5. Dry the residual ethanol and resuspend the double-stranded DNA in the TE buffer.

Storage

Store at RT up to 3 month.

Store at 4°C up to 6 month.

Store at -20°C up to 1 year.

Shipping Temperature: 4°C

Note: OnePCR™ HiFi is light sensitive and should be stored and protected from light.

RT, PCR & QPCR REAGENTS

OnePCR™ HotStar

Cat No.	Size
MB206-0100	100 Reactions (2 X 1.25 ml)
SM206-0100	100 Reactions (2 X 1.25 ml)

Features

- No post-staining processing of DNA required.
- Direct loading onto your agarose gel for analysis.
- Speed – No destaining requirement.
- Specificity – Reduce the non-specific amplification products, thus significantly improving the specificity of PCR reactions.
- No need to prepare PCR Reagents.
- Sensitivity – High degree of sensitivity as the ethium bromide.
- Compatibility – Use the Blue Light or UV to detect the signal.

Description

OnePCR™ HotStar is a ready-to-use PCR reaction mixture. Simply add primers, template, and water, the reagent will execute primer extensions and other molecular biology applications. OnePCR™ HotStar is a pre-mixed solution containing Hot start *Taq* DNA polymerase, PCR buffer, dNTPs, gel loading dyes, enhancer, and fluorescence dye. OnePCR™ HotStar, which contains the fluorescence dye, is directly detected on BLook LED transilluminator or UV epi-illuminator after the DNA electrophoresis. Hot start *Taq* DNA polymerase has a non-template-dependent terminal transferase activity that adds a 3' deoxyadenosine to product ends, and has a 5'→3' exonuclease activity (but not 3'→5' exonuclease activity). OnePCR™ HotStar mixture is supplied at the 2X concentration to allow 50% of the final reaction volume to be used for the addition of primer and template solutions. The enzyme s contains a proprietary antibody that blocks polymerase activity at ambient temperatures. Activity is restored after the initial denaturation step in PCR cycling at 94°C, thereby providing an automatic "hot start" for *Taq* DNA polymerase in PCR.

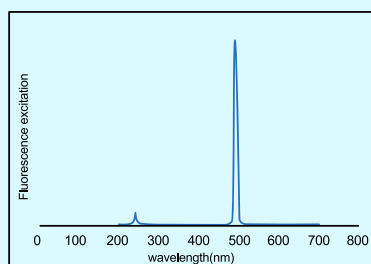

Fig. 1a. Fluorescence excitation spectra of the fluorescence dye

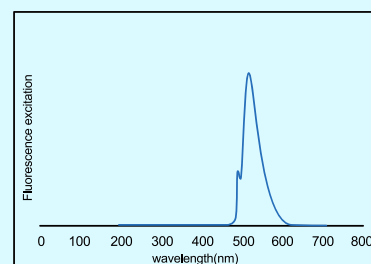

Fig. 1b Fluorescence emission spectra of the fluorescence dye

Tracking Dyes

- Bromophenol Blue, Xylene Cyanol FF.

Protocol

Standard PCR with OnePCR™ HotStar:

1. For each 50 µl reaction, assemble the following components in a 0.2 ml PCR tube on ice just prior to use:

Component	Volume (µl)
OnePCR™ HotStar	25
Forward primer, 5~10 µM	1
Reverse primer, 5~10 µM	1
DNA template	Variable
Add ddH ₂ O to	50

2. Mix gently. If necessary, centrifuge briefly. Cap tubes and place in the thermal cycler.

3. Process in the thermal cycler for 25-35 cycles as follows:

Initial Denaturation	2-5 minutes at 94°C	} 30 cycles
Denaturation	20-40 seconds at 94°C	
Annealing	1 minute at the proper annealing temperature	
Extension	2 mins at 72°C	
Final extension	5 mins at 72°C	

Note: Optimal conditions for amplification will vary depending on the primers and thermal cycler used. It may be necessary to optimize the system for individual primers, template, and thermal cycler.

4. After the PCR reaction, DNA electrophoresis will detect the PCR product.

5. Use the UV or blue-light transilluminator or UV epi-illuminator to photograph the gel.

Note: When the DNA concentration is less than 4pg, it may cause the migratory shift when performing the electrophoresis. To remedy this observation, we recommend to conduct the following steps (please refer to the experimental procedures), or use the PCR Clean-Up & Gel Extraction Kit [see Cat. No. NA006-0100] to remove the fluorescence dye prior to post-staining with the Novel Green [Cat. No. LD002-0500] or Novel Green *plus* [Cat. No. LD003-0500] again for restoring the DNA molecular weight in the original position.

Removal of Fluorescence Dye

1. Immerse the PCR product containing the fluorescence dye into the 100 mM NaCl and add 2.5 volumes of absolute or 95% ethanol.
2. Incubate on ice for 20 minutes.
3. Centrifuge the mixture at 4°C for at least 10 minutes.
4. Remove the suspension of ethanol and wash the pellet with 1ml of 70% ethanol.
5. Dry the residual ethanol and resuspend the double-stranded DNA in the TE buffer.

Storage

Store at RT up to 3 month.

Store at 4°C up to 6 month.

Store at -20°C up to 1 year.

Shipping Temperature: 4°C

Note: OnePCR™ HotStar is light sensitive and should be stored and protected from light.

RT, PCR & QPCR REAGENTS

OnePCR™ Plus

Cat No.	Size
MB207-0100	100 Reactions (2 X 1.25 ml)
SM207-0100	100 Reactions (2 X 1.25 ml)

Features

- No post-staining processing of DNA required.
- Direct loading onto your agarose gel.
- Time efficiency – No destaining requirement.
- No need to prepare PCR Reagents.
- Sensitivity – High degree of sensitivity as the ethidium bromide.
- Compatibility – Use the UV light or blue light to detect the signal.

Description

OnePCR™ Plus is a ready-to-use PCR reaction mixture. Simply add primers, template, and water, the reagent will execute primer extensions and other molecular biology applications. OnePCR™ Plus is a pre-mixed solution containing *Taq* DNA polymerase, PCR reaction buffers, dNTPs, gel loading dyes, and fluorescence dye. OnePCR™ Plus contains the *Taq* DNA polymerase, which is purified from the *E. coli*. and exhibits the *Thermus aquaticus* DNA polymerase gene. This enzyme has a 5'→3' DNA polymerase and the 5'→3' exonuclease activity but lacks the 3'→5' exonuclease activity.

OnePCR™ Plus also contains the fluorescence dye, which is directly detected on BLoK™ LED Transilluminator (Cat. No. BK001) or UV epi-illuminator after the DNA electrophoresis. OnePCR™ Plus mixture is supplied at the 2X concentration to allow 50% of the final reaction volume to be used for the addition of primer and template solutions. Reagents are provided with the sufficient amplification reactions of 50 µl each.

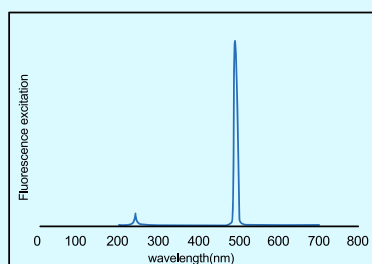

Fig. 1a. Fluorescence excitation spectra of the fluorescence dye

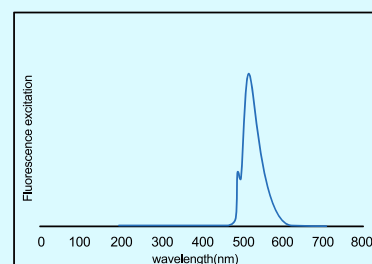

Fig. 1b Fluorescence emission spectra of the fluorescence dye

Application

- PCR Amplification

Tracking Dyes

- Bromophenol Blue, Xylene Cyanol FF.

Required Materials

- Electrophoresis equipments.
- DNA Markers (optional).
- BLoK LED Transilluminator or UV epi-illuminator

Buffer Preparation

- TE buffer, pH8.0 [Selective]: 10 mM Tris-HCl, pH 8.0 with 1 mM EDTA

OnePCR™ Plus Protocol

Standard PCR with OnePCR™ Plus

- For each 50 µl reaction, assemble the following components in a 0.2 ml PCR tube on ice before the experiment:

Component	Volume (µl)	Final Concentration
OnePCR™ Plus	25	1X
Forward primer (5-10 µM)	1	0.1-0.2 µM
Reverse primer (5-10 µM)	1	0.1-0.2 µM
DNA template	Variable	-
Add ddH ₂ O to	50	

- Mix gently. If necessary, centrifuge briefly. Cap the tube and place it in the thermal cycler.
- To process in the thermal cycler for 25-35 cycles as follows:

Process	Temperature [°C]	Time	Cycles
Initial Denaturation	94	5 minutes	1
Denaturation	94	20-40 seconds	25-35
Annealing	the proper annealing temperature	1 minute	
Extension	72	2 minutes	
Final extension	72	5 minutes	1

Note: Optimal conditions for amplification will vary depending on the primers and thermal cycler used. It may be necessary to optimize the system.

- After the PCR reaction, DNA electrophoresis will detect the PCR product.
- Use the BLoK LED Transilluminator (Cat. No. BK001) or UV epi-illuminator to photograph the gel.

Removal of fluorescence dye

- Immerse the PCR product containing the fluorescence dye into the 100 mM NaCl and add 2.5 volumes of absolute or 95% ethanol.
- Incubate on ice for 20 minutes.
- Centrifuge the mixture at 4°C for at least 10 minutes.
- Remove the suspension of ethanol and wash the pellet with 1ml of 70% ethanol.
- Dry the residual ethanol and resuspend the double-stranded DNA in the TE buffer.

Storage

Store at room temperature up to 3 months.
Store at -20°C up to 1 year.

Store at 4°C up to 6 months
Shipping temperature: 4°C

RT, PCR & QPCR REAGENTS

2x PCR mix

Cat No.	Size
MB208-0100	100 Reactions (2 × 1.25 ml)
SM208-0100	100 Reactions (2 × 1.25 ml)

Feature

- No need to prepare PCR Reagents.

Description

2x PCR mix is a ready-to-use PCR reaction mixture. Simply add primers, template, the reagent will execute primer extensions and other molecular biology applications. 2x PCR mix is a pre-mixed solution containing *Taq* DNA polymerase, PCR reaction buffers, and dNTPs. 2x PCR mix contains the *Taq* DNA polymerase, is purified from the *E. coli.*, and expressing the *Thermus aquaticus* DNA polymerase gene. This enzyme has a 5'→3' DNA polymerase and the 5'→3' exonuclease activity but lacks the 3'→5' exonuclease activity. 2x PCR mix mixture is supplied at the 2X concentration to allow 50% of the final reaction volume to be used for the addition of primer and template solutions. Reagents are provided with the sufficient amplification reactions of 50 µl each.

Application

- PCR Amplification

Buffer Preparation

- TE buffer, pH8.0 (Selective): 10 mM Tris-HCl, pH 8.0 with 1 mM EDTA

Quality Control

The quality of the 2x PCR mix is tested on a lot-to-lot basis to ensure consistent product quality.

Required Materials

- Electrophoresis equipments.
- DNA Markers.
- BLook LED transilluminator or UV epi-illuminator.

Storage

Store at room temperature up to 3 months
 Store at 4°C up to 6 months
 Store at -20°C up to 1 year
 Shipping temperature: 4°C

BlooDireX PCR™ System

Cat No.	Size
SM211-0100	100 Reactions

Features

- Sample is added directly to PCR reaction, therefore there is no need for time-consuming and expensive DNA purification steps.
- Amplify fragment size: up to 5 kilo base.
- High speed: 15-30 seconds/ kilo base.
- Master Mix format with premixed gel loading dye minimizes possibility of cross-contamination, reduces sample handling time and allows directly loading to gel.

Description

The BlooDireX PCR™ System is designed for amplification of DNA from whole blood. It contains BlooDireX PCR™ and Novel Juice, suitable for PCR from blood sample directly. BlooDireX PCR™ is performed PCR directly from sample with no prior DNA extraction or sample preparation. For blood, stored at 4°C or frozen, and preserved with EDTA, citrate or heparin are all suitable for this master mix. BlooDireX PCR™ is a premixed ready-to-use solution containing reaction buffers, dNTPs, loading dye, glycerol, PCR enhancers, and hot-start DNA polymerase. The hot-start *taq* prevents non-specific amplification due to mispriming and/or formation of primer dimers before thermal cycling, and it also exhibits 2X faster elongation rate than conventional *Taq*. The modified hot-start DNA polymerase is resistant to most PCR inhibitors and retains its activity in the PCR reaction. BlooDireX PCR™ is supplied at the 2X concentration to allow approximately 50% of the final reaction volume to be used for the addition of primer and template solutions. Reagents are provided with the sufficient amplification reactions of 20 µl each. Novel Juice is a non-mutagenic fluorescent reagent that produces instant visualization of DNA bands upon blue light (e.g. BLook™, Cat. No. zzzzzBK001) or UV illumination of agarose gels. Supplied in 6X DNA Loading Buffer, Novel Juice is used to prepare DNA markers or samples for loading on agarose or polyacrylamide gels. Novel Juice is the most sensitive staining reagent available for detecting the double-stranded DNA (dsDNA). It contains three tracking dyes (bromophenol blue, xylene cyanol FF, and orange G) for visually tracking the DNA migration during the electrophoresis process. It is ideal for the environment requiring a safe, non-hazardous alternative to Ethidium Bromide (EtBr). Approximate fluorescence excitation / emission: 300, 495 / 537 nm, bound to nucleic acid.

Applications

- Genotyping.
- Transgenic detection.
- Gene knockout analysis.

Quality Control

The quality of the BlooDireX PCR™ is tested on a lot-to-lot basis to ensure consistent product quality.

Kit Contents

Contents	Size
BlooDireX PCR™	1000 µl
Novel Juice	1000 µl

Required Materials

Blood samples
 PCR tubes
 PCR thermal cycler
 Electrophoresis equipment

RT, PCR & QPCR REAGENTS

One-Step RT-PCR Kit

Cat No.	Size
MB300-0050	50 Reactions
SM300-0050	50 Reactions

Description

The One-Step RT-PCR with HotStar *Taq* System is designed for the convenient, sensitive, and reproducible detection and analysis of RNA molecules by RT-PCR. Components for both cDNA synthesis and PCR are combined in a single tube, using gene-specific primers and target RNAs from either total RNA or mRNA. Reverse transcription automatically follows PCR cycling without additional steps. The kit consists of two major components: RT/HotStar *Taq* Mix and 2X Reaction Mix. The RT/HotStar *Taq* Mix contains a mixture of Reverse Transcriptase and HotStar *Taq* DNA Polymerase for optimal cDNA synthesis and PCR amplification. Reverse transcriptase is a modified version of Moloney Murine Leukemia Virus (M-MLV) RT, engineered to reduce RNase H activity and increase thermal stability. HotStar *Taq* DNA polymerase is *Taq* DNA polymerase complexed with a proprietary antibody that inhibits polymerase activity at ambient temperatures. The antibody is denatured and polymerase activity is restored during the denaturation step in PCR cycling at 94°C. This provides an automatic "hot start" in PCR, increasing sensitivity, specificity, and yield. The 2X Reaction Mix consists of a proprietary buffer system optimized for reverse transcription and PCR amplification, Mg²⁺ optimized for universal use, deoxyribonucleotide triphosphates, and stabilizers. This convenient 2X format allows further addition of template and primer at any desired concentration. One addition tube of MgSO₄ (50 mM) is included in the kit. Reagents are provided with the sufficient amplification reactions of 50 µl each.

Kit Contents

Component	Size
RT/ HotStar <i>Taq</i> Mix	50 µl
2X Reaction Mix	1.25 ml
50 mM Magnesium Sulfate	200 µl

Important Parameters

RNA

- High quality intact RNA is essential for successful full-length cDNA synthesis.
- RNA should be devoid of any RNase contamination and aseptic conditions should be maintained.

Primers

- Gene specific primers (GSP) are recommended. Use of oligo(dT) or random primers are not recommended as they result in generation of non-specific products in the one-step procedure and the amount of RT-PCR product may be reduced.
- A final primer concentration of 0.2 µM for each primer is generally optimal. However, for best results, a primer titration using 0.15–0.5 µM is recommended.
- Design primers that anneal to sequence in exons on both sides of an intron or exon/exon boundary of the mRNA to allow differentiation between amplification of cDNA and potential contaminating genomic DNA.
- Primers should not be self-complementary or complementary to each other at the 3' ends.

Magnesium Concentration

- The 2X Reaction Mix includes magnesium at a final concentration of 3 mM. This works well for most targets; however, the optimal concentration may range from 3 to 6 mM. If necessary, use the separate tube of 50-mM magnesium sulfate to increase the magnesium concentration. Use the following table to determine the amount of MgSO₄ to add to achieve the specified concentration (in a 50-µl PCR with 25 µl of 2X Reaction Mix)

Volume of 50-mM MgSO ₄ (per 50-µl Rxn)	Final MgSO ₄ Conc.
1 µl	4.0 mM
2 µl	5.0 mM
3 µl	6.0 mM

Decrease the amount of water in the reaction accordingly

dNTPs

- 200 µM dNTP concentration is optimal for most RT-PCR reactions.

Recommendations and Tips

- Keep all components, reaction mixes, and samples on ice. After preparation of the samples, transfer them to a pre-heated thermal cycler (45–55°C, depending on the cDNA step temperature) and immediately start the RT-PCR amplification program.
- Efficient cDNA synthesis can be accomplished in a 15–30 minutes incubation at 45–55°C.
- The reverse transcriptase is inactivated, HotStar *Taq* DNA polymerase is reactivated and the RNA/cDNA hybrid is denatured during the 2 minutes incubation at 94°C.
- The annealing temperature should be 10°C below the melting temperature of the primers used.
- The extension time varies with the size of the amplicon [approximately 1 minutes per 1 kb of amplicon].
- For all targets up to 3 kb, 1 µl of RT/ HotStar *Taq* Mix is sufficient.

Quality Control

The product is tested functionally using 10 pg of total HeLa RNA as the template for amplification of a 353-bp segment of β-actin mRNA (40 cycles). A minimum of 25 ng of the RT-PCR product was obtained under these conditions. primers used.

RT, PCR & QPCR REAGENTS

GScript RTase

Cat No.	Size
MB303-0050	50 Reactions
SM303-0050	50 Reactions

Description

The GScript RTase is recombinant M-MLV RTase expressed in *E. coli* and purified to homogeneity. It has lower RNase H activity and high thermal stability. The enzyme is widely used to synthesize first-strand cDNA at temperatures up to 55°C with increased specificity, higher yields of cDNA, and more full-length product than other reverse transcriptases. It can generate cDNA from 100 bp to 12 Kb.

Quality Control

The quality of the GScript RTase is tested on a lot-to-lot basis to ensure consistent product quality.

Kit Contents

Contents	Size
GScript RTase (200 units/μl)	50 μl
5X RT Buffer	250 μl
0.1 M DTT	100 μl

GScript First-Strand Synthesis Kit

Cat No.	Size
MB305-0050	50 Reactions
SM305-0050	50 Reactions

Description

The GScript First-Strand Synthesis Kit is a recombinant M-MLV RTase expressed in *E. coli* and purified to homogeneity. It has a lower RNase H activity and a high thermal stability. The enzyme is widely used to synthesize first-strand cDNA at temperatures up to 55°C with increased specificity, higher yields of cDNA, and more full-length product than other reverse transcriptases. It can generate cDNA from 100 bp to 12 Kb. The GScript RTase has a special activity with its secondary structure, rendering stabilization during the reverse transcription reaction.

Required Materials

- Microcentrifuge tubes
- RiboIN™ RNase inhibitor
- Water bath/Dry bath
- Nuclease-free H₂O

Quality Control

The quality of the GScript RTase is tested on a lot-to-lot basis to ensure consistent product quality.

Kit Contents

Contents	Size
Oligo(dT) ₂₀ (50 μM)	50 μl
5X 1st strand buffer	250 μl
DTT (0.1 M)	100 μl
dNTP mix (10 mM)	50 μl
GScript RTase (200 U/ μl)	50 μl

GScript One-Step RT-PCR Kit

Cat No.	Size
MB306-0050	50 Reactions
SM306-0050	50 Reactions

Description

The GScript One-Step RT-PCR Kit contains all necessary reagents for both reverse transcription and PCR amplification to occur in a single reaction tube. Components for both cDNA synthesis and PCR are combined in a single tube, using gene-specific primers and target RNAs from either total RNA or mRNA. Reverse transcription automatically follows PCR cycling without additional steps. The GScript One-Step RT-PCR Kit consists of two major components: GScript Enzyme Mix and 5X Reaction Mix, provided a convenient format for highly sensitive and specific RT-PCR using any RNA template. Our proprietary RT-PCR buffer contains enhancer that optimizes the two reactions in a "single step". Together with a specially formulated RT-PCR buffer, this GScript One-Step RT-PCR kit offers the end-users an efficient, easy to use and reliable alternative to conventional. The GScript Enzyme Mix is for optimal cDNA synthesis and PCR amplification. The enzyme mix uses a mixture of M-MLV Reverse Transcriptase and Hotstart *Taq* DNA polymerase in an optimized reaction buffer. The 5X Reaction Mix consists of a proprietary buffer system optimized for reverse transcription and PCR amplification, Mg²⁺ optimized for universal use, deoxyribonucleotide triphosphates, and stabilizers. This convenient 5X format allows further addition of template and primer at any desired concentration. Sufficient reagents are provided for 50 amplification reactions of 50 μl each.

Quality Control

The quality of the GeneDireX GScript One-Step RT-PCR Kit is tested on a lot-to-lot basis to ensure consistent product quality.

Kit Contents

Contents	Size
GScript Enzyme Mix	100 μl
5X Reaction Mix	550 μl

RT, PCR & QPCR REAGENTS

QStrip One-Step RT-qPCR Mix

Cat No.	Size	Package
MB309-0008	8 Reactions	0.1 mL 8-Tubes Strip X 1
MB309-0048	48 Reactions	0.1 mL 8-Tubes Strip X 6

Features

- Lyophilized beads form – stable in room temperature.
- Premix components to ensure greater reproducibility between reactions, minimize pipetting steps, and reduce the potential for pipetting errors and contamination.
- Time efficiency – included most reagents for RT-qPCR reaction.
- Thermal flexible- the temperature of reverse transcription can be raised to 61°C.

Description

The QStrip One-Step RT-qPCR Mix has been freeze-dried to a bead format. Beads are stable at room temperature and designed to perform a fast and easy methods for one-step reverse transcription real-time PCR (RT-qPCR). The QStrip One-Step RT-qPCR Mix is provided in 0.1 ml tubes containing one lyophilized bead for one reaction. The lyophilized bead contains reverse transcriptase, DNA polymerases, dNTPs and buffer components at optimal concentrations. The additional reagents required are water, primers, and template RNA. The supermix is applicable for TaqMan probes system. The reverse transcriptase is modified from that be able to tolerate high temperature to 61°C, which is helpful for reverse transcription of RNA templates to unravel the complex RNA secondary structures. The specific DNA polymerase allows for high specificity and reproducible amplification.

Applications

- Detection of expressed genes.
- Examination of transcript variants.

Required Materials

- qPCR thermal cycling instrument
- RNase-free water
- Gene-specific primers and fluorogenic probe.
- ROX reference dye (optional)
- RNase inhibitor (optional)

Quality Control

Each lot of QStrip One-Step RT-qPCR Mix is functional test to ensure lot-to-lot reproducibility

GScriptULTRA First-Strand Synthesis Kit (Random primer)

Cat No.	Size
MB310-H100	100 Reactions
SM310-H100	100 Reactions

Feature

- Time efficiency – included most reagents for reverse transcription reaction.

Description

The GScriptULTRA First-Strand Synthesis Kit (Random primer) provides a convenient and sensitive of cDNA synthesis from RNA molecules by reverse transcription (RT). The kit consists of five major components: GScriptULTRA RTase, 5X 1st strand buffer, 0.1 M DTT, 50 μM Random Hexamers primer, and 10 mM dNTP (Deoxyribonucleotide triphosphates) mix. The GScriptULTRA RTase is a recombinant Moloney Murine Leukemia Virus (M-MLV) transcription polymerase expressed in *E. coli* and purified to homogeneity. It has lower RNase H activity and high thermal stability. The enzyme is widely used to synthesize first-strand cDNA at temperatures up to 55°C with increased specificity, higher yields of cDNA, and more full-length product than other reverse transcriptases. It can generate cDNA from 100 base pairs (bps) to 12 Kilo base pairs (kb). The 5X Reaction Mix buffer is optimized for reverse transcription. The DTT breaks the disulfide bonds, loosen the secondary structure of RNA, and helps in initiation for cDNA synthesis. Random Hexamers are short oligodeoxyribonucleotides of random sequences [d(N)₆] that anneal to random complementary sites on a target RNA. The dNTP solution consists all four nucleotides (dATP, dCTP, dGTP, dTTP), suitable for use in cDNA synthesis.

Application

Downstream application for PCR to detection of expressed genes, examination of transcript variants, or generation of cDNA templates for cloning and sequencing.

Required Materials

- Microcentrifuge tubes
- PCR instrument or water / Dry bath
- RNase-free H₂O
- RNase Inhibitor (10 U/μl)

Quality Control

The quality of the GScriptULTRA First-Strand Synthesis Kit (Random primer) is tested on a lot-to-lot basis to ensure consistent product quality.

Kit Contents

Contents	Size
Random Hexamers (50 μM)	100 μl
5X 1st strand buffer	500 μl
DTT (0.1 M)	100 μl
dNTP mix (10 mM)	100 μl
GScriptULTRA RTase	40 μl

RT, PCR & QPCR REAGENTS

GScript^{ULTRA} First-Strand Synthesis Kit (Oligo-dT)

Cat No.	Size
MB310-T100	100 Reactions
SM310-T100	100 Reactions

Feature

- Time efficiency – included most reagents for reverse transcription reaction.

Description

The GScript^{ULTRA} First-Strand Synthesis Kit (Oligo-dT) provides a convenient and sensitive of cDNA synthesis from RNA molecules by reverse transcription (RT). The kit consists of five major components: GScript^{ULTRA} RTase, 5X 1st strand buffer, 0.1 M DTT, 50 μM Oligo(dT)₂₀, and Random Hexamers primer, and 10 mM dNTP (Deoxyribonucleotide triphosphates) mix. The GScript^{ULTRA} RTase is a recombinant Moloney Murine Leukemia Virus (M-MLV) transcription polymerase expressed in *E. coli* and purified to homogeneity. It has lower RNase H activity and high thermal stability. The enzyme is widely used to synthesize first-strand cDNA at temperatures up to 55°C with increased specificity, higher yields of cDNA, and more full-length product than other reverse transcriptases. It can generate cDNA from 100 base pairs (bps) to 12 Kilo base pairs (kb). The 5X Reaction Mix buffer is optimized for reverse transcription. The DTT breaks the disulfide bonds, loosen the secondary structure of RNA, and helps in initiation for cDNA synthesis. The Oligo(dT)₂₀ consist of a stretch of 20 deoxythymidines that anneal to poly(A) tails of eukaryotic mRNAs. The primers are optimized for constructing cDNA libraries. The dNTP solution consists all four nucleotides (dATP, dCTP, dGTP, dTTP), suitable for use in cDNA synthesis.

Application

Downstream application for PCR to detection of expressed genes, examination of transcript variants, or generation of cDNA templates for cloning and sequencing.

Required Materials

- Microcentrifuge tubes
- RNase-free H₂O
- PCR instrument or water / Dry bath
- RNase Inhibitor (10 U/μl)

Quality Control

The quality of the GScript^{ULTRA} First-Strand Synthesis Kit (Oligo-dT) is tested on a lot-to-lot basis to ensure consistent product quality.

GScript First-Strand Synthesis Kit

Cat No.	Size
MB601-0100	100 Reactions
SM601-0100	100 Reactions

Features

- 5'→3' DNA polymerase activity
- High reaction rate: 10 seconds/kb.
- Generates blunt end amplicon.
- 3'→5' exonuclease (proofreading) activity.
- High fidelity: 70 times higher than *Taq* polymerase.

Description

GDP-HiFi is a new recombinant enzyme with genetic modification for its amino acid sequence, which results 70 times better fidelity than *Taq* DNA polymerase and an extremely fast elongation rate (as fast as 15 seconds per kilo base, kb). GDP-HiFi has higher stability at high temperature, and this property makes GDP-HiFi perform very well for GC-rich PCR. Being highly thermo-stable, GDP-HiFi DNA Polymerase can remain viable even after being subjected to boiling for 2 minutes. This special enzyme has been modified genetically and needs less concentration of magnesium than other polymerases. The suggestion for magnesium ion in the reaction is 0.8 to 1.2 mM. 10X GDP-HiFi PCR buffer contains no magnesium. A tube of 25 mM MgSO₄ is provided. Further optimization can be achieved for different targets of DNAs. Reagents are provided for 100 PCR reactions of 50 μl each.

Kit Contents

Contents	Size
GDP-HiFi DNA Polymerase (1 U/μl)	100 μl
10X GDP-HiFi PCR buffer	1 ml
25 mM Magnesium Sulfate	1 ml
dNTP Mix (2mM each)	1 ml
DMSO	1 ml

Applications

- Clinical diagnosis.
- Knockout analysis.

Quality Control

The quality of the GDP-HiFi DNA Polymerase is tested on a lot-to-lot basis to ensure consistent product quality.

RT, PCR & QPCR REAGENTS

Oligo (dT)₂₀ primer

Cat No.	Size
MB701-0050	50 µl
SM701-0050	50 µl

Concentration: 50 µM

Store at -20°C in a non-frost-free freezer

Guaranteed stable for 6 months when properly stored

Description

Oligo(dT)₂₀ primer is a string of 20 deoxythymidylic acid residues that hybridizes to the poly(A) tail of mRNA and can be used as a primer for the first strand cDNA synthesis with the reverse transcriptase. The primer is supplied in the DEPC water at a concentration of 50 µM.

Application

cDNA synthesis with a reverse transcriptase

Quality control

The quality of the oligo (dT)₂₀ primer is tested on a lot-to-lot basis to ensure consistent product quality.

Required Materials

Equipments for reverse transcription

Random Hexamers primer

Cat No.	Size
MB702-0100	100 µl
SM702-0100	100 µl

Description

Random Hexamers are short oligodeoxyribonucleotides of random sequences [d(N)₆] that anneal to random complementary sites on a target DNA or RNA and serve as primers for DNA synthesis by a DNA polymerase or reverse transcriptase. During cDNA generation, random priming gives random coverage to all regions of the RNA to generate a cDNA pool containing various lengths of cDNA. Random priming is incapable of distinguishing between the mRNA and other RNA species present in the reaction.

Applications

- cDNA synthesis using a Reverse Transcriptase with RNA templates
- DNA synthesis using the Klenow fragment with DNA templates
- DNA probe synthesis for use in Southern, Northern, and in situ hybridization applications

Quality control

This product is qualified in a cDNA reaction.

RiboIN™ RNase Inhibitor

Cat No.	Size
RI001-2500	2500U
SR001-2500	2500U

Description

RiboIN™ RNase Inhibitor is a protein which specifically inhibits ribonucleases. It is used in applications such as *in vitro* translation, cDNA synthesis, RNA *in vitro* synthesis, RNA purifications, etc. RNase inhibitor is easier to use and eliminate than the vanadyl ribonucleosides. It has a high binding affinity for pancreatic-type ribonucleases such as RNase A. RiboIN™ RNase Inhibitor inhibits a broad range of RNases, including RNase A, RNase B, RNase C, but it is not effective against RNase 1, RNase T1, S1 Nuclease, RNase H.

Applications

- RNA purification
- *in vitro* RNA transcription
- cDNA preparation by reverse transcription
- RT-PCR
- *in vitro* protein synthesis
- Separation and identification of specific ribonuclease activities

Quality control

One Unit Definition

One unit is the amount of protein required to inhibit the activity of 5 ng of RNase A by 50%.

Purity

RiboIN™ RNase Inhibitor has been experimented in 12.5% SDS-PAGE electrophoresis.

It's greater than 90% in purity. The specific activity is →80,000 units/mg.

Recommended Use

cDNA Synthesis: 40 units/20 µl of reaction mixture, RiboIN™ RNase Inhibitor protects mRNA and improves total cDNA yields including percent total full length of cDNA.

RT-PCR: 40 units/20 µl of reaction mixture.

In Vitro Transcription: 20-40 units/10 µl of reaction mixture, RiboIN™ RNase Inhibitor has been shown to be useful for the isolation of intact RNA transcripts using T3, T7 and SP6 RNA Polymerases.

RT, PCR & QPCR REAGENTS

amaR OnePCR™

Cat No.	Size
SM213-0250	100 Reactions (2 X 1.25 ml)

Features

- No post-staining processing of DNA required.
- Direct loading onto your agarose gel for analysis.
- Speed – No destaining requirement.
- No need to prepare PCR Reagents.
- Sensitivity – High degree of sensitivity as the ethium bromide.
- Compatibility – Use the blue light or UV to detect the signal.

Description

The amaR OnePCR™ is a ready-to-use PCR reaction mixture. Simply add primers, template, and water, the reagent will execute primer extensions and other molecular biology applications. The amaR OnePCR™ is a pre-mixed solution containing *Taq* DNA polymerase, PCR buffer, dNTPs, gel loading dyes, and fluorescence dye. The amaR OnePCR™ which contains the *Taq* DNA polymerase, is purified from the *E. coli*, and expressing the *Thermus aquaticus* DNA polymerase gene. This enzyme has a 5'→ 3' DNA polymerase and the 5'→ 3' exonuclease activity but lacks the 3'→ 5' exonuclease activity. The amaR OnePCR™, which contains the fluorescence dye, is directly detected on BLook™ LED transilluminator [Cat. No. BK001] or UV epi-illuminator after the DNA electrophoresis. The amaR OnePCR™ contents red tracking dyes, provide a safe, non-toxic and non-mutagenic alternative to ethidium bromide for instantaneous band visualization, that are environmentally friendly containing no hazardous chemicals. The tracking dyes that run at 10 bp on a 1% agarose gel. The amaR OnePCR™ mixture is supplied at the 2X concentration to allow approximately 50% of the final reaction volume to be used for the addition of primer and template solutions. The reagents are provided with the sufficient amplification reactions of 20 µl each.

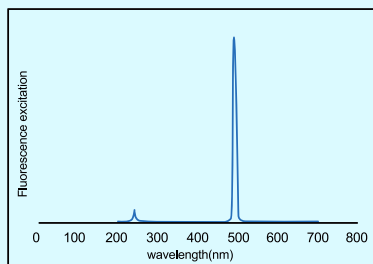

Fig. 1a. Fluorescence excitation spectra of the fluorescence dye

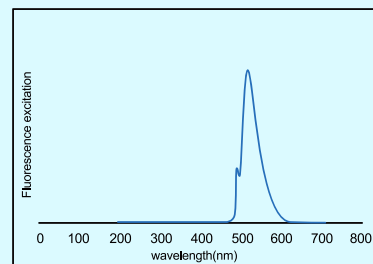

Fig. 1b Fluorescence emission spectra of the fluorescence dye

The amaR OnePCR™, which contains the fluorescence dye, is directly detected on BLook™ LED transilluminator [Cat. No. BK001] or UV epi-illuminator after the DNA electrophoresis. The amaR OnePCR™ contents red tracking dyes, provide a safe, non-toxic and non-mutagenic alternative to ethidium bromide for instantaneous band visualization, that are environmentally friendly containing no hazardous chemicals. The tracking dyes that run at 10 bp on a 1% agarose gel. The amaR OnePCR™ mixture is supplied at the 2X concentration to allow approximately 50% of the final reaction volume to be used for the addition of primer and template solutions. The reagents are provided with the sufficient amplification reactions of 20 µl each.

Tracking Dye

- Bromophenol Blue, Xylene Cyanol FF.

Protocol

Standard PCR with amaR OnePCR™ :

1. For each 20 µl reaction, assemble the following components in a 0.2 ml PCR tube on ice just prior to use:

Component	Volume (µl)	Final Concentration
amaR OnePCR™	10	1X
Forward primer, 5~10 µM	Variable	0.1-0.2 µM
Reverse primer, 5~10 µM	Variable	0.1-0.2 µM
DNA template	Variable	4 pg~500 ng
Add ddH ₂ O to	20	

2. Mix gently. If necessary, centrifuge briefly. Cap tubes and place in the thermal cycler.

3. Process in the thermal cycler for 25~35 cycles as follows:

Initial Denaturation	2~5 minutes at 94°C	} 30 cycles
Denaturation	20~40 seconds at 94°C	
Annealing	1 minute at the proper annealing temperature	
Extension	2 mins at 72°C	
Final extension	5 mins at 72°C	

Note: Optimal conditions for amplification will vary depending on the primers and thermal cycler used. It may be necessary to optimize the system for individual primers, template, and thermal cycler.

4. After the PCR reaction, DNA electrophoresis will detect the PCR product.

5. Use the UV or blue-light transilluminator or UV epi-illuminator to photograph the gel.

Note: When the DNA concentration is less than 4pg, it may cause the migratory shift when performing the electrophoresis. To remedy this observation, we recommend to conduct the following steps (please refer to the experimental procedures), or use the PCR Clean-Up & Gel Extraction Kit [see Cat. No. SN006-0100] to remove the fluorescence dye prior to post-staining with the Novel Green [Cat. No. SL002-0500] or Novel Green Plus [Cat. No. SL003-0500] again for restoring the DNA molecular weight in the original position.

Removal of Fluorescence Dye

1. Immerse the PCR product containing the fluorescence dye into the 100 mM NaCl and add 2.5 volumes of absolute or 95% ethanol.
2. Incubate on ice for 20 minutes.
3. Centrifuge the mixture at 4°C for at least 10 minutes.
4. Remove the suspension of ethanol and wash the pellet with 1ml of 70% ethanol.
5. Dry the residual ethanol and resuspend the double-stranded DNA in the TE buffer.

Storage

Store at RT up to 3 month.

Store at 4°C up to 6 month.

Store at -20°C up to 1 year.

Shipping Temperature: 4°C

Note: amaR OnePCR™ is light sensitive and should be stored and protected from light.

RT, PCR & QPCR REAGENTS

amaR OnePCR™ HiFi

Cat No.	Size
SM215-0250	100 Reactions (2 X 1.25 ml)

Features

- No post-staining procession.
- Direct loading onto your agarose gel for analysis.
- Time Efficiency- No destaining requirement.
- Effective for the amplification of GC-rich targets.
- No need to prepare PCR reagents.
- Sensitivity- High degree of sensitivity as the ethium bromide.
- Compatibility - Use the Blue Light or UV to detect the signal.
- Exhibits strong 3'→5' exonuclease activity

Description

The amaR OnePCR™ HiFi is a ready-to-use PCR reaction mixture. Simply adding primers and template, the reagent will execute primer extensions and other molecular biology applications. The amaR OnePCR™ HiFi is a pre-mixed solution containing GDP-HiFi DNA polymerase, PCR buffer, dNTPs, gel loading dyes, enhancer, and fluorescence dye. It contains the fluorescence dye, which is directly detected on the blue-light transilluminator or UV epilluminator after the DNA electrophoresis. The GDP-HiFi DNA polymerase exhibits excellent processivity, elongation capability, and strong proof-reading activity. The elongation rate of this enzyme is approximately 2 times higher than that of *Taq* DNA polymerase. The elongation rate is 106-138 bases/s. and produces blunt end PCR products. The amaR OnePCR™ HiFi contents red tracking dyes, provide a safe, non-toxic and non-mutagenic alternative to ethidium bromide for instantaneous band visualization, that are environmentally friendly containing no hazardous chemicals. The tracking dyes that run at 10 bp on a 1% agarose gel. The amaR OnePCR™ HiFi mixture is supplied at the 2X concentration to allow approximately 50% of the final reaction volume to be used for the addition of the primer and template solutions. The reagents are provided with sufficient amplification reactions of 20 µl each.

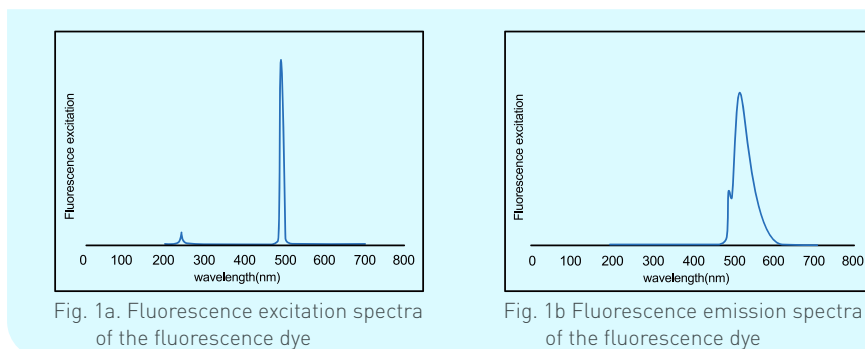

Fig. 1a. Fluorescence excitation spectra of the fluorescence dye

Fig. 1b Fluorescence emission spectra of the fluorescence dye

Tracking Dye

- Amaranth

Protocol

Standard PCR with amaR OnePCR™ HiFi:

1. For each 20 µl reaction, assemble the following components in a 0.2 ml PCR tube on ice just prior to use:

Component	Volume (µl)	Final Concentration
amaR OnePCR™ HiFi	10	1X
Forward primer, 5~10 µM	Variable	0.1-0.2 µM
Reverse primer, 5~10 µM	Variable	0.1-0.2 µM
DNA template	Variable	4 pg~500 ng
Total	20	

2. Mix gently. If necessary, centrifuge briefly. Cap tubes and place in the thermal cycler.

3. Process in the thermal cycler for 25-35 cycles as follows:

Initial Denaturation	2-5 minutes at 94°C	} 30 cycles
Denaturation	20-40 seconds at 94°C	
Annealing	1 minute at the proper annealing temperature	
Extension	2 mins at 72°C	
Final extension	5 mins at 72°C	

Note: Optimal conditions for amplification will vary depending on the primers and thermal cycler used. It may be necessary to optimize the system for individual primers, template, and thermal cycler.

4. After the PCR reaction, DNA electrophoresis will detect the PCR product.
5. Use the UV or blue-light transilluminator or UV epilluminator to photograph the gel.

Note: When the DNA concentration is less than 4 pg, it may cause the migratory shift when performing the electrophoresis. To remedy this observation, we recommend to conduct the following steps (please refer to the experimental procedures), or use the PCR Clean-Up & Gel Extraction Kit (see Cat. No. SN006-0100) to remove the fluorescence dye prior to post-staining with the Novel Green (Cat. No. SL002-0500) or Novel Green Plus (Cat. No. SL003-0500) again for restoring the DNA molecular weight in the original position.

Removal of Fluorescence Dye

1. Immerse the PCR product containing the fluorescence dye into the 100 mM NaCl and add 2.5 volumes of absolute or 95% ethanol.
2. Incubate on ice for 20 minutes.
3. Centrifuge the mixture at 4°C for at least 10 minutes.
4. Remove the suspension of ethanol and wash the pellet with 1ml of 70% ethanol.
5. Dry the residual ethanol and resuspend the double-stranded DNA in the TE.

Storage

Storage: Store at RT up to 1 months.

Store at 4°C up to 6 months.

Store at -20°C up to 1 year.

Note: amaR OnePCR™ HiFi is light sensitive and should be stored and protected from light.

RT, PCR & QPCR REAGENTS

amaR OnePCR™ HotStar

Cat No.	Size
SM216-0250	100 Reactions (2 X 1.25 ml)

Features

- No post-staining processing of DNA required.
- Direct loading onto your agarose gel.
- Time efficiency – No destaining requirement.
- Specificity – Reduce the non-specific amplification products, thus significantly improving the specificity of PCR reactions
- No need to prepare PCR Reagents.
- Sensitivity – High degree of sensitivity as the ethidium bromide.
- Compatibility – Use the UV light or blue light to detect the signal.

Description

AmaR OnePCR™ HotStar is a ready-to-use PCR reaction mixture. Simply add primers, template, and water, the reagent will execute primer extensions and other molecular biology applications. AmaR OnePCR™ HotStar is a pre-mixed solution containing hot-start *Taq* DNA polymerase, PCR reaction buffers, dNTPs, gel loading dyes, enhancer, and fluorescence dye. AmaR OnePCR™ HotStar contains hot-start *Taq* DNA polymerase, which exhibits non-template-dependent terminal transferase activity that adds a 3' deoxyadenosine to product ends, and 5' → 3' exonuclease activity (but not 3' → 5' exonuclease activity). The hot-start *Taq* DNA polymerase is *Taq* DNA polymerase complexes with a proprietary antibody that blocks activity at room temperatures. When heat to 95°C, the enzyme is restored, providing an automatic "hot start" for *Taq* DNA polymerase in PCR, increasing the sensitivity and specificity of PCR reaction. AmaR OnePCR™ HotStar contains a red tracking dye, provide a safe, non-toxic and non-mutagenic alternative to Ethidium Bromide for instantaneous band visualization, the dye is environmentally friendly containing no hazardous chemicals. The AmaR OnePCR™ HotStar contains only a single fast-running tracking dye that migrates at approximately 10 base pair in a 1% agarose gel. AmaR OnePCR™ HotStar also contains the fluorescence dye, which is directly detected on BLook™ LED Transilluminator (Cat. No.BK001) or UV epi-illuminator after the DNA electrophoresis. AmaR OnePCR™ HotStar mixture is supplied at the 2X concentration to allow 50% of the final reaction volume to be used for the addition of primer and template solutions. Reagents are provided with sufficient amplification reactions of 20 µl each.

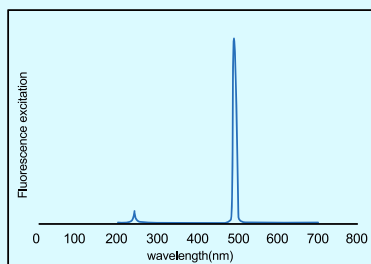

Fig. 1a. Fluorescence excitation spectra of the fluorescence dye

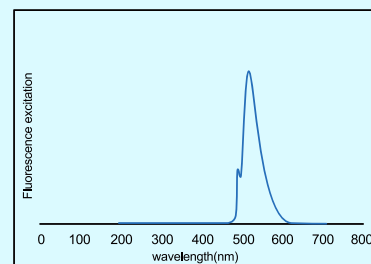

Fig. 1b Fluorescence emission spectra of the fluorescence dye

Tracking Dye

- Amaranth

Application

- PCR Amplification

Quality Control

The quality of the amaR OnePCR™ HotStar is tested on a lot-to-lot basis to ensure consistent product quality.

Required Materials

- Electrophoresis equipments.
- DNA Markers (optional).
- BLook LED Transilluminator or UV epi-illuminator

Buffer Preparation

- TE buffer, pH8.0 (Selective): 10 mM Tris-HCl, pH 8.0 with 1 mM EDTA

AmaR OnePCR™ HotStar Protocol

1. For each 20 µl reaction, assemble the following components in a 0.2 ml PCR tube on ice before the experiment:

Component	Volume (µl)	Final Concentration
amaR OnePCR™ HotStar	10	1X
Forward primer (5-10 µM)	Variable	0.1-0.2 µM
Reverse primer (5-10 µM)	Variable	0.1-0.2 µM
DNA template	Variable	-
Add ddH ₂ O to	20	

2. Mix gently. If necessary, centrifuge briefly. Cap the tube and place it in the thermal cycler.

3. To process in the thermal cycler for 25-35 cycles as follows:

Process	Temperature (°C)	Time	Cycles
Initial Denaturation	94	2-5 minutes	1
Denaturation	94	20-40 seconds	25-35
Annealing	the proper annealing	1 minute	
Extension	temperature	2 minutes	
Final extension	72	5 minutes	1

Note: Optimal conditions for amplification will vary depending on the primers and thermal cycler used. It may be necessary to optimize the system.

continued on next page ►

RT, PCR & QPCR REAGENTS

4. After the PCR reaction, DNA electrophoresis will detect the PCR product.
5. Use the BLook™ LED Transilluminator (Cat. No. BK001) or UV epi-illuminator to photograph the gel.
Note: If the concentration of PCR amplification product is less than 4 µg, it may cause the migratory shift when performing the electrophoresis. To remedy this observation, we recommend to conduct the following Removal of fluorescence dye steps (please refer to the experimental procedures), or use the PCR Clean-Up & Gel Extraction Kit (Cat. No. SN006-0100) to remove the fluorescence dye prior to post-staining with the Novel Green (Cat. No. SL002-0500) or Novel Green Plus (Cat. No. SL003-0500) again for restoring the DNA molecular weight in the original position.

Removal of fluorescence dye

1. Immerse the PCR product containing the fluorescence dye into the 100 mM NaCl and add 2.5 volumes of absolute or 95% ethanol.
2. Incubate on ice for 20 minutes.
3. Centrifuge the mixture at 4°C for at least 10 minutes.
4. Remove the suspension of ethanol and wash the pellet with 1ml of 70% ethanol.
5. Dry the residual ethanol and resuspend the double-stranded DNA in the TE buffer.

RT, PCR & QPCR REAGENTS

One-Step qRT-PCR Kit

Cat No.	Size
SM307-0100	100 Reactions
SM307-1000	1000 Reactions

Feature

- Time efficiency – included most reagents for qRT-PCR reaction.

Description

The One-Step qRT-PCR Kit are compatible with *TaqMan* probes. The Kit provides a convenient, sensitive, and reproducible method to detect and quantify the RNA molecules by quantitative reverse transcription polymerase chain reaction (qRT-PCR). The components for cDNA synthesis, PCR amplification, and quantification are combined in a kit, using gene-specific primers, probes, and target RNAs from either total RNA or mRNA. The kit consists of three major components: RT/HotStar *Taq* Mix, 2X Reaction Mix, and 50 mM Magnesium Sulfate (MgSO₄). The RT/HotStar *Taq* Mix contain a mixture of Reverse Transcriptase (RTase) and HotStar *Taq* DNA polymerase for optimal cDNA synthesis and PCR amplification. The RTase is modified from the Moloney Murine Leukemia Virus (M-MLV) RTase, engineered to reduce RNase H activity and increase thermal stability. The HotStar *Taq* DNA polymerase is *Taq* DNA polymerase complexes with a proprietary antibody that blocks activity at ambient temperatures. Activity is restored after the enzyme activation step at 95°C, thereby providing an automatic "hot-start" for *Taq* DNA polymerase in PCR, increasing the sensitivity and specificity of PCR reaction. The 2X Reaction Mix consists of 6 mM MgSO₄, deoxyribonucleotide triphosphates (dNTPs), and stabilizers provide a proprietary buffer system optimized for reverse transcription and PCR amplification. One addition tube of 50 mM MgSO₄ is included in the kit. For COVID-19 detection, the optimal concentration is 4 mM. An additional 0.5 µl for each reaction is recommended.

Kit Contents

Contents	Size (100 Reactions)	Size (1000 Reactions)
RT/HotStar <i>Taq</i> Mix	50 µl	500 µl
2X Reaction Mix	1.25 ml	12.5 ml
50 mM MgSO ₄	200 µl	1 ml x 2 vials

Applications

- Detection of expressed genes.
- Examination of transcript variants.

Quality Control

The quality of the One-Step qRT-PCR Kit is tested on a lot-to-lot basis to ensure consistent product quality.

Required Materials

- Reaction tubes and caps /qPCR plates and seals
- qPCR thermal cycling instrument
- Gene-specific primers and fluorogenic probe
- RNase inhibitor (optional)
- qPCR thermal cycling instrument
- DEPC- treat water
- ROX reference dye (optional)

Compatible Instruments

Depending on the use of fluorescent PCR instrument, check on the following table, optimal cycling conditions will vary with different instruments:

Product Name	qRT-PCR Thermal Cycling Instrument
One-Step qRT-PCR Kit	Applied Biosystems™ 7000, 7300, 7500, 7700, and 7900HT Real-Time PCR Systems Applied Biosystems™ GeneAmp™ 5700 Bio-Rad™ iCycler™ Agilent™ Mx3000P™, Mx3005P™, and Mx4000™ Corbett Research Rotor-Gene™ MJ Research DNA Engine Opticon™, Opticon™ 2, and Chromo4™ Real-Time Detector Cepheid SmartCycler™ thermal cyclers

RT, PCR & QPCR REAGENTS

SimplyGreen qPCR Master Mix, Rox

Cat No.	Size
SQ101-0100	100 Reactions

Description

A 2X concentrated mix of *Taq* polymerase, dNTPs, MgCl₂, fluorescent dye (detection), reference dye and proprietary buffer components, the SimplyGreen qPCR Master Mix, Rox provides a convenient, reliable and robust set-up for performing quantitative real-time analysis of DNA samples. Designed specifically for the aforementioned niche of application, the components of SimplyGreen qPCR Master Mix, Rox promise topnotch performance with respect to sensitivity, signal-to-noise ratio and elimination of primer dimers. Furthermore, the proprietary chemical modification of the DNA polymerase included in this mastermix allows for hot-start PCR, conferring a significant reduction in non-specific PCR amplification that is otherwise of a common occurrence with regular *Taq* polymerases. Based on the fact that the qPCR instruments can vary from user to user, we suggest that the SimplyGreen qPCR Master Mix, Rox is compatible with qPCR instrument: ABI® 7000, 7300, 7700, 7900, 7900HT StepOnePlus™; StepOne™; OpenArray PRISM™ Sequencing Detection Series.

Required Materials

- Real-time PCR tubes
- Real-time PCR instrument
- RNase-Free H₂O

Applications

- Gene Expression (mRNA) Analysis
- microRNA & Noncoding RNA Analysis
- Genetic Variation Analysis

Real-time PCR Instrument

Product Name	Real-time PCR Instrument
SimplyGreen qPCR Master Mix, Rox	ABI® 7000, 7300, 7700, 7900, 7900HT, StepOnePlus™, StepOne™, OpenArray, Biometra TOptical, PRISM™ Sequencing Detection Series, Fluidigm BioMark™ Wafergene SmartChip System, TianLong TL998 System

Storage Conditions

Upon arrival, the SimplyGreen qPCR Master Mix, Rox should be stored at -20°C and protected from light. After each experiment, the leftover thawed mix can be stored at 4°C if it is to be used within the next 3 months. Avoid repeated freeze-thaw cycles to retain maximum performance. The SimplyGreen qPCR Master Mix, Rox is stable for 1 year from the date of shipping when stored and handled properly.

SimplyGreen qPCR Master Mix, Low Rox

Cat No.	Size
SQ102-0100	100 Reactions

Description

A 2X concentrated mix of *Taq* polymerase, dNTPs, MgCl₂, fluorescent dye (detection), reference dye and proprietary buffer components, the SimplyGreen qPCR Master Mix, Low Rox provides a convenient, reliable and robust set-up for performing quantitative real-time analysis of DNA samples. Designed specifically for the aforementioned niche of application, the components of SimplyGreen qPCR Master Mix, Low Rox promise topnotch performance with respect to sensitivity, signal-to-noise ratio and elimination of primer dimers. Furthermore, the proprietary chemical modification of the DNA polymerase included in this mastermix allows for hot-start PCR, conferring a significant reduction in non-specific PCR amplification that is otherwise of a common occurrence with regular *Taq* polymerases. Based on the fact that the qPCR instruments can vary from user to user, we suggest that the SimplyGreen qPCR Master Mix, Low Rox is compatible with qPCR instrument: ABI® 7500 (Fast); Viia™; QuantStudio; Illumina Eco; Stratagene® Mx3000, Mx3005, Mx4000.

Required Materials

- Real-time PCR tubes
- Real-time PCR instrument
- RNase-Free H₂O

Applications

- Gene Expression (mRNA) Analysis
- microRNA & Noncoding RNA Analysis
- Genetic Variation Analysis

Real-time PCR Instrument

Product Name	Real-time PCR Instrument
SimplyGreen qPCR Master Mix, Low Rox	ABI® 7500, 7500 Fast, Viia™ 7, QuantStudio, QuantStudio 3, QuantStudio 5, BioGene InSyte™ Illumina Eco, Stratagene® Mx3000, Mx3005, Mx4000 Analytikjena qTower Series

Storage Conditions

Upon arrival, the SimplyGreen qPCR Master Mix, Low Rox should be stored at -20°C and protected from light. After each experiment, the leftover thawed mix can be stored at 4°C if it is to be used within the next 3 months. Avoid repeated freeze-thaw cycles to retain maximum performance. The SimplyGreen qPCR Master Mix, Low Rox is stable for 1 year from the date of shipping when stored and handled properly.

RT, PCR & QPCR REAGENTS

SimplyGreen qPCR Master Mix, No Rox

Cat No.	Size
SQ103-0100	100 Reactions

Description

A 2X concentrated mix of *Taq* polymerase, dNTPs, MgCl₂, fluorescent dye (detection), and proprietary buffer components, the SimplyGreen qPCR Master Mix, No Rox provides a convenient, reliable and robust set-up for performing quantitative real-time analysis of DNA samples. Designed specifically for the aforementioned niche of application, the components of SimplyGreen qPCR Master Mix, No Rox promise topnotch performance with respect to sensitivity, signal-to-noise ratio and elimination of primer dimers. Furthermore, the proprietary chemical modification of the DNA polymerase included in this mastermix allows for hot-start PCR, conferring a significant reduction in non-specific PCR amplification that is otherwise of a common occurrence with regular *Taq* polymerases. Based on the fact that the qPCR instruments can vary from user to user, we suggest that the SimplyGreen qPCR Master Mix, No Rox is compatible with qPCR instrument: BioRad® CFX96, CFX384, Chromo4™, CFX Connect™, Opticon 2, MiniOpticon™; Roche LightCycler® [2.0, 1.5, 480, 1536, Nano]; MJ Research Opticon™, Opticon™2, Chromo® 4; Corbett Rotor-gene® (3000, 6200, 62H0, 6500, 65H0, 6600).

Required Materials

- Real-time PCR tubes
- Real-time PCR instrument
- RNase-Free H₂O

Applications

- Gene Expression (mRNA) Analysis
- microRNA & Noncoding RNA Analysis
- Genetic Variation Analysis

Real-time PCR Instrument

Product Name	Real-time PCR Instrument
SimplyGreen qPCR Master Mix, No Rox	BioRad® CFX96, CFX384, Chromo4™, CFX Connect™, Opticon 2, MiniOpticon™, Roche LightCycler® (480, 1536, Nano) MJ Research Opticon™, Opticon™ 2, Chromo® 4, Enigma® ML Eppendorf® Realplex 4, BioGene SynChron™ Corbett Rotor-gene® (3000, 6200, 62H0, 6500, 65H0, 6600) Eppendorf Mastercycler® realplex (s, 4, 4s), Pro (S, 384), Nexus (gradient, eco, flat), Cepheid SmartCycler®, GeneXpert Idaho LightScanner® (24, 32), RapidCycler®2, R.A.P.I.D (LT, LT Food), RAZOR EX, JBAIDS, Qiagen Rotor-Gene™ (Q, 6000), Takara Dice™ Thermo Scientific PikoReal, DNA-Technology DT96, DTlite, DT-322 Bioer LineGene (3310/3320, K FQD-48A, I, II, 9620, 9640, 9660, 9680) Bioneer Exicycler™

Storage Conditions

Upon arrival, the SimplyGreen qPCR Master Mix, No Rox should be stored at -20°C and protected from light. After each experiment, the leftover thawed mix can be stored at 4°C if it is to be used within the next 3 months. Avoid repeated freeze-thaw cycles to retain maximum performance. The SimplyGreen qPCR Master Mix, No Rox is stable for 1 year from the date of shipping when stored and handled properly.

NUCLEIC ACID PURIFICATION SYSTEM

Extract Reagent (Total RNA Isolation Reagent)

Cat No.	Size	Sample:	Format:
NA003-0100	100 ml	Fresh tissues (Up to 50 mg) Cultured animal cells (Up to 5 X 10 ⁶)	Reagent form Operation time: 15-20 minutes
SN003-0100	100 ml	Cultured bacterial cells (Up to 1 X 10 ⁹) Fresh blood/frozen blood (Up to 300 µl) Serum (Up to 100 µl)	Elution volume: 50-200 µl

Features

- Fast procedure and delivering high-quality total RNA.
- Ready-to-use RNA for high performance in any downstream application.
- Consistent RNA yield from the starting material with a small amount.
- Provide sufficient reagents and 3 steps to treat the samples.

Description

The Extract Reagent provides an efficient 3-step method to isolate the total RNA from the tissue, cultured animal and bacterial cells, blood, and serum. This unique reagent system ensures the total RNA with a high yield and good quality from samples of unlimited size. If a larger sample is required, the reagent volume can be scaled proportionally, making this reagent not only very user-friendly but also highly versatile. The RNA phenol extraction is not required, and the entire procedure can be completed in 60 minutes. The total RNA is ready for use in RT-PCR, Northern Blotting, cDNA Synthesis and Mapping.

Kit Contents

Contents	Size
ER Buffer 1	50 ml X 1 bottle
ER Buffer 2	6 ml X 1 bottle

Application

Molecular biology applications, including real-time RT-PCR, microarray analysis, next-generation sequencing (RNA-Seq), northern blotting, and cloning.

Required Materials

- Mortar and pestle
- Isopropanol
- Absolute ethanol for preparing 70% ethanol in H₂O (RNase free)
- Microcentrifuge tubes (RNase-free)
- RNase A (50 mg/ml)
- RNase-free H₂O
- Chloroform
- β-mercaptoethanol
- Water bath/Dry bath

Quality Control

The quality of the Extract Reagent is tested on a lot-to-lot basis to ensure consistent product quality

PR Reagent (Plant Total RNA Isolation Kit)

Cat No.	Size	Sample:	Operation time:
NA007-0100	100 ml	Up to 100 mg of fresh plant tissue Up to 50 mg of dry plant tissue	120 minutes
SN007-0100	100 ml	Format: Reagent form	Release volume: 50-100 µl

Features

- Fast procedure delivering high-quality total RNA.
- Ready-to-use RNA for high performance in any downstream application.
- Consistent RNA yield from the starting material with a small amount Provides sufficient reagents and 3 steps to treat samples.

Description

The PR Reagent provides an easy 3-step method to isolate the total RNA from plant samples. This unique reagent system ensures the total RNA with a high yield and good quality from the most common plant samples as well as samples high in polysaccharides. If a larger sample is required, the kit volume can be scaled up proportionately, making the kit not only user-friendly but also highly versatile. The RNA phenol extraction is not required, and the entire procedure can be completed in 2 hours. The total RNA (up to 80 µg for fresh plant tissue) is ready for use in RT-PCR, Northern Blotting, cDNA Synthesis and Mapping.

Kit Contents

Contents	Size
PR buffer 1	100 ml X 1 bottle
PR buffer 2	10 ml X 1 bottle

Applications

- RT-PCR of RNA.
- Northern blotting.
- Real-time RT-PCR.

Required Materials

- Mortar and pestle
- β-mercaptoethanol
- Isopropanol
- Microcentrifuge tubes (RNase free)
- Chloroform
- Water bath/Dry bath
- RNase-free H₂O
- 70% ethanol in H₂O (RNase free)

Quality Control

The quality of the PR Reagent (Plant Total RNA Isolation Kit) is tested on a lot-to-lot basis to ensure consistent product quality.

NUCLEIC ACID PURIFICATION SYSTEM

Total RNA Isolation Kit (Blood/ Cultured Cell/ Fungus)

Cat No.	Size	Sample: Whole blood (up to 300 µl) Mammalian cells (up to 1 x 10 ⁷) Bacterial cells (up to 1 x 10 ⁹) Fungus Cells (up to 1 x 10 ⁸)	Yield: Up to 30 µg Format: Spin column Operation time: 25-40 minutes Elution volume: 50-200 µl
NA017-0100	100 Reactions		
SN017-0100	100 Reactions		

Features

- Fast procedure and delivering high-quality total RNA.
- Ready-to-use RNA for high performance in any downstream application.
- Consistent RNA yield from a small amount of starting material.

Description

The Total RNA Isolation Kit provides a fast, simple, and cost-effective method for the isolation of total RNA from the whole blood, mammalian cells and bacterial cells. Detergents and chaotropic salt are used to lyse cells and inactivate RNase. The specialized high-salt buffering system allows RNA species bases to bind to the glass fiber matrix of the spin column while contaminants pass through the column. Impurities are efficiently washed away, and the pure RNA is eluted with the RE Buffer without phenol extraction or alcohol precipitation. The RNA purified with the Total RNA Isolation Kit is suitable for a variety of routine applications, including the RT-PCR, cDNA synthesis, Northern Blotting, differential display, primer extension, and mRNA selection. The entire procedure can be completed within 25-40 minutes.

Application

Downstream molecular biology applications, including real-time RT-PCR, microarray analysis, next-generation sequencing (RNA-Seq), northern blotting, and cloning.

Required Materials

- Ethanol (96-100%).
- RNase-free pipet tips and 1.5 ml microcentrifuge tubes.
- 14.3 M β-mercaptoethanol.
- For the optional step (DNA Residue Degradation): Add 2 µl of the DNase I (2 KU/ml) mixed in a reaction buffer (50 mM Tris-HCl (pH 7.5) and 10 mM MnCl₂, 50 µg/ml BSA at 25°C) to the final elution sample. Let it stand for 10 minutes at the room temperature.
- For the Gram-positive bacteria sample: lysozyme buffer (20 mg/ml lysozyme; 20 mM Tris-HCl; 2 mM EDTA; 1% TritonX-100; pH 8.0, prepare the lysozyme buffer immediately prior to use).
- For the fungus sample: lyticase or zymolyase, sorbitol buffer (1.2 M sorbitol; 10 mM CaCl₂; 0.1 M Tris-HCl, pH 7.5; 35 mM β-mercaptoethanol).

Quality Control

The quality of the Total RNA Isolation Kit (Blood/ Cultured Cell/ Fungus) is tested on a lot-to-lot basis to ensure consistent product quality.

Total RNA Isolation Kit (Plant)

Cat No.	Size	Sample: 100 mg of fresh plant tissue or 50 mg of dry plant tissue Format: Spin column	Operation time: Within 60 minutes Elution volume: 50-200 µl Yield: Up to 30 µg
NA020-0100	100 Reactions		
SN020-0100	100 Reactions		

Features

- Delivers high-quality total RNA with the fast procedure, ready-to-use RNA for high performance in any downstream application.
- Consistent RNA yield from a small amount of the starting material.

Description

The Total RNA Isolation Kit provides a fast, simple, and cost-effective method for total RNA isolation from plant samples. Detergents and chaotropic salt are used to lyse cells and inactivate RNase. The specialized high-salt buffering system allows RNA species, longer than 100 bases, to bind to the glass fiber matrix of the spin column. The isolated total RNA is suitable for a variety of routine applications including RT-PCR, Northern Blotting, cDNA Synthesis and Mapping. The entire procedure can be completed within 60 minutes.

Applications

- RT-PCR.
- Northern blotting.
- Real-time RT-PCR.

Required Materials

- Liquid nitrogen
- Water bath/Dry bath
- RNase-free pipet tips and 1.5 ml microcentrifuge tubes
- Absolute ethanol
- 14.3 M β-mercaptoethanol
- Mortar and pestle
- Isopropanol

Quality Control

The quality of the Total RNA Isolation Kit (Plant) is tested on a lot-to-lot basis to ensure consistent product quality.

Kit Contents

Contents	Size
Buffer RL	110 ml X 1 bottle
Buffer RA	45 ml X 1 bottle
Buffer RO	25 ml X 1 bottle
Buffer W1	45 ml X 1 bottle
Buffer W2 (Add ethanol)	15 ml X 1 bottle (60 ml X 1 bottle)
Buffer RE	10 ml X 1 bottle
DR Column	50 pieces X 2 bags
Collection Tube	50 pieces X 2 bags

Kit Contents

Contents	Size
Buffer RP	110 ml X 1 bottle
Buffer W1	45 ml X 1 bottle
Buffer W2 (add ethanol)	15 ml X 1 bottle (60 ml X 1 bottle)
Buffer RE	10 ml X 1 bottle
RP Column	50 pieces X 2 bags
Collection Tube	50 pieces X 2 bags

NUCLEIC ACID PURIFICATION SYSTEM

Total RNA Isolation Kit (Tissue)

Cat No.	Size	Sample: Up to 30 mg of fresh tissue Up to 25 mg of paraffin-embedded tissue Format: Spin column	Operation time: 25-40 minutes Elution volume: 50 µl Yield: Up to 30 µg
NA021-0100	100 Reactions		
SN021-0100	100 Reactions		

Features

- Delivers high-quality total RNA with the fast procedure. Ready-to-use RNA for high performance in any downstream application.
- Consistent RNA yield from the starting material with a small amount.

Description

The Total RNA Isolation Kit (Tissue) provides a fast, simple, and cost-effective method to isolated total RNA from tissue sample. Detergents and chaotropic salt are used to lyse cells and inactivate RNase. The specialized high-salt buffering system allows RNA species to bind to the glass fiber matrix of the spin column while contaminants pass through the column. Impurities are efficiently washed away, and the pure RNA is eluted with Buffer RE without phenol extraction or alcohol precipitation. RNA purified with The Total RNA Isolation Kit is suitable for a variety of routine applications including RT-PCR, cDNA Synthesis, Northern Blotting, Differential display, Primer Extension and mRNA Selection. The entire procedure can be completed within 25-40 minutes.

Applications

- RT-PCR of RNA.
- Northern blotting.
- Real-time RT-PCR.

Required Materials

- Liquid nitrogen
- Ethanol (96-100%)
- Mortar and pestle
- Water bath/Dry bath
- 14.3 M β-mercaptoethanol
- Isopropanol
- RNase-free pipet tips and 1.5 ml microcentrifuge tubes
- For Paraffin-Embedded Tissue: xylene, absolute ethanol

Quality Control

The quality of the Total RNA Isolation Kit (Tissue) is tested on a lot-to-lot basis to ensure consistent product quality.

Kit Contents

Contents	Size
Buffer RR	45 ml X 1 bottle
Buffer W1	45 ml X 1 bottle
Buffer W2 (add Ethanol)	15 ml X 1 bottle (60 ml X 1 bottle)
Buffer RE	10 ml X 1 bottle
RT Column	50 pieces X 2 bags
Collection Tubes	50 pieces X 2 bags

Extract Reagent (Genomic DNA Isolation Reagent)

Cat No.	Size	Sample: 50 mg of fresh tissue, 5 x 10 ⁶ culture animal cells 1 x 10 ⁹ bacterial cells	Format: Reagent form Operation time: 90 minutes Elution volume: 50-100 µ
NA001-0100	100 ml		
SN001-0100	100 ml		

Features

- Fast procedure and delivering high-quality genomic DNA
- Ready-to-use DNA for high performance in any downstream application
- Consistent DNA yields from a small amount of the starting material
- Time flexibility
- Ease of DNA extraction technique or method
- Expense reduction

Description

Extract Reagent (Genomic DNA Isolation Reagent) provides an easy 3-step method to isolate high yields of total DNA (from tissue, cultured animal and bacterial cells, blood and serum). This unique reagent ensures total DNA with a high yield and good quality from samples of unlimited size. If a large sample is required, the reagent volume can be scaled proportionately, making this reagent not only very user-friendly but also highly versatile. The DNA phenol extraction is not required and the entire procedure can be completed in 90 minutes.

Applications

- Quantity of DNA needed
- Purity of DNA required
- Molecular weight and size of DNA
- Downstream applications of DNA

Required Materials

- Homogenizer
- RNase A (50 mg/ml)
- Chloroform
- Isopropanol
- 70% ethanol
- Water Bath/Dry Bath
- Microcentrifuge tubes
- TE (Tris-EDTA, pH8.0) or ddH₂O

Quality Control

The quality of the Extract Reagent (Genomic DNA Isolation Reagent) is tested on a lot-to-lot basis to ensure consistent product quality.

Buffer Preparation

TE Buffer (Tris-EDTA, pH8.0): 10 mM Tris-HCl, pH 8.0 with 1 mM EDTA

NUCLEIC ACID PURIFICATION SYSTEM

PG Reagent (Plant Genomic DNA Isolation Reagent)

Cat No.	Size	Sample: Up to 100 mg of fresh tissue or 50 mg of dry plant tissue	Operation time: 120 minutes Elution volume: 50-200 µl
NA002-0100	100 ml	Format: Reagent form	
SN002-0100	100 ml		

Features

- Consistent DNA yields from a small amount of the starting material.
- Ease of DNA extraction technique or method.
- Time flexibility.
- Expense reduction.

Description

The PG Reagent provides an easy 3-step method to isolate a high yield of total DNA (including genomic, mitochondrial, and chloroplast DNA) from the plant tissue and cells. This unique reagent is able to lyse the most common plant samples as well as samples with high polysaccharides. If a large sample is required, the reagent volume can be scaled up proportionally, making this reagent not only user-friendly but also highly versatile. The DNA phenol extraction is not required, and the entire procedure can be completed in 90 minutes. The extracted total DNA is ready for use in PCR, Real-time PCR, Southern Blotting, Mapping and RFLP.

Applications

- Quantity of DNA needed.
- Purity of DNA required.
- Molecular weight and size of the DNA.
- Downstream DNA applications.

Required Materials

- Homogenizer (mortar and pestle)
- RNase A (50 mg/ml)
- Isopropanol
- 70% ethanol
- Chloroform
- Microcentrifuge tubes

Quality Control

The quality of the PG Reagent is tested on a lot-to-lot basis to ensure consistent product quality.

Buffer Preparation

TE Buffer (Tris-EDTA, pH8.0): 10 mM Tris-HCl, pH 8.0 with 0.1mM EDTA

Genomic DNA Isolation Reagent Kit (Blood/Cultured Cell/Tissue)

Cat No.	Size	Sample: 300 µl of the whole blood 200 µl of the buffy coat Mammalian cells (up to 1×10^7) Bacterial cells (up to 1×10^9) Fungus cells (up to 1×10^9) 30 mg of animal tissues	Format: Reagent Operation time: within 60 minutes
NA022-0100	100 Reactions		
SN022-0100	100 Reactions		

Features

- Fast, reproducible and easy processing by using reagent or spin column system.
- Isolated genomic DNA is compatible with various downstream applications.
- To isolate high quality genomic DNA.

Description

The Genomic DNA Isolation Reagent Kit (Blood/Cultured Cell/Tissue) is a reagent system kit. The kit is designed specifically for genomic DNA isolation from the whole blood, frozen blood, buffy coat, cultured animal/bacterial cells, fungus cells and tissue. This unique reagent system ensures genomic DNA with high yield and good quality from samples. The entire procedure can be completed in one hour without phenol/ chloroform extraction. Purified genomic DNA is suitable for use in PCR or other enzymatic reactions.

Kit Contents

Contents	Size
Buffer BR	100 ml X 1 bottle
Buffer BC	35 ml X 1 bottle
Buffer BP	12 ml X 1 bottle

Applications

- Restriction enzyme digestion.
- Southern blotting.
- PCR amplification.
- Real-Time PCR assay.

Required Materials

- RNase A (10 mg/ml)
- Air-dry equipments
- For the tissue sample: Proteinase K (10 mg/ml), Micropestle
- 1.5 ml Microcentrifuge tubes
- Absolute ethanol
- Water bath/Dry bath
- Isopropanol

Quality Control

The quality of the Genomic DNA Isolation Reagent Kit (Blood/ Cultured Cell/ Tissue) is tested on a lot-to-lot basis to ensure consistent product quality.

NUCLEIC ACID PURIFICATION SYSTEM

Dual Genomic DNA Isolation Kit (Plant)

Cat No.	Size	Sample: 100 mg of fresh plant tissue or 50 mg of dry plant tissue	Operation time: within 90-120 minutes
NA018-0100	100 Reactions	Format: Reagent and spin column	Elution volume: 50-200 µl
SN018-0100	100 Reactions		

Features

- Ready-to-use genomic DNA for high performance in any downstream application
- Highly purified and high yield genomic DNA can be extracted from various plant samples
- Optimized plant lysis buffer for the efficient lysis

Description

The Dual Genomic DNA Isolation Kit (Plant) is designed to combine reagent system and spin column system. The kit could be used to isolate genomic DNA from plant samples with high yield and good quality. The spin column system is designed to purify or concentrate DNA products which have been previously isolated with the reagents. The entire procedure can be completed in 2 hour without phenol extraction. Purified DNA is suitable for use in PCR or other enzymatic reactions.

Applications

- Gene cloning
- Real time PCR
- SNP genotyping
- Southern blotting

Required Materials

- RNase A (50 mg/ml)
- Absolute ethanol
- Liquid nitrogen
- Chloroform
- Mortar and pestle
- Water bath/Dry bath
- Isopropanol
- Microcentrifuge tubes

Kit Contents

Contents	Size
Buffer PG	100 ml X 1 bottle
Buffer BD	100 ml X 1 bottle
Buffer W1	45 ml X 1 bottle
Buffer W2 (add ethanol)	15 ml X 1 bottle (60 ml X 1 bottle)
Buffer BE	10 ml X 1 bottle
DGP Column	50 pieces X 2 bags
Collection Tube	50 pieces X 2 bags

Quality Control

The quality of the Dual Genomic DNA Isolation Kit (Plant) is tested on a lot-to-lot basis to ensure consistent product quality.

Genomic DNA Isolation Kit (Plant)

Cat No.	Size	Sample: Up to 100 mg of fresh plant tissue Up to 50 mg of dry plant tissue	Column capacity: Up to 50 µg
NA025-0100	100 Reactions	Format: Spin column	Operation time: Within 60 minutes
SN025-0100	100 Reactions		

Features

- Delivering high-quality genomic DNA with the fast procedure.
- Ready-to-use genomic DNA for high performance in any downstream application.
- Highly purified and high yield genomic DNA can be extracted from various samples.
- Optimized lysis buffer for the efficient lysis.
- Designed to rapidly purify high-quality DNA using spin column format.

Description

The Genomic DNA Isolation Kit (Plant) is designed specifically for genomic DNA isolation from plant samples. This unique buffer system ensures total DNA with high yield and good quality from samples. The spin column system is designed to purify or concentrate DNA samples which have been previously isolated using buffers. The entire procedure can be completed in one hour without phenol / chloroform extraction. The isolated DNA is suitable for PCR or other enzymatic reactions.

Applications

- Gene cloning.
- PCR.
- Southern blotting.
- SNP genotyping.

Required Materials

- Mortar and pestle
- Ethanol (96-100%)
- RNase A (50 mg/ml)
- Microcentrifuge tubes
- Isopropanol
- Water bath/Dry bath

Kit Contents

Contents	Size
Buffer PL	55 ml X 1 bottle
Buffer W1	45 ml X 1 bottle
Buffer W2 (Add ethanol)	15 ml X 1 bottle (60 ml X 1 bottle)
Buffer BE	10 ml X 1 bottle
PC Column	50 pieces X 2 bags
Collection tube	50 pieces X 2 bags

Quality Control

The quality of the Genomic DNA Isolation Kit (Plant) is tested on a lot-to-lot basis to ensure consistent product quality.

NUCLEIC ACID PURIFICATION SYSTEM

Dual Genomic DNA Isolation Kit (Tissue)

Cat No.	Size	Sample: 30~100 mg of fresh animal tissue Up to 25 mg of paraffin-embedded tissue	Operation time: Within 60 minutes Elution volume: 50~200 µl
NA019-0100	100 Reactions	Format: Reagent and spin column	
SN019-0100	100 Reactions		

Features

- Ready-to-use genomic DNA for high performance in any downstream application.
- Highly purified and high yield genomic DNA can be extracted from various tissue samples.
- Optimized tissue lysis buffer for the efficient lysis.

Description

The DUAL Genomic DNA Isolation Kit (Blood/Cultured Cell/Fungus) is designed to combine the reagent system and spin column system. The kit could be used to isolate the genomic DNA from the whole blood, frozen blood, buffy coat, cultured animal/ bacterial cells, and fungus. This unique reagent system ensures the DNA with a high yield and good quality from the samples. The spin column system is designed to purify or concentrate DNA products which have been previously isolated with the reagents. The entire procedure can be completed in 1 hour without the phenol/ chloroform extraction. The purified DNA is suitable for use in PCR or other enzymatic reactions.

Kit Contents

Contents	Size
Buffer DG	100 ml X 1 bottle
Buffer BD	100 ml X 1 bottle
Buffer W1	45 ml X 1 bottle
Buffer W2 (add ethanol)	15 ml X 1 bottle (60 ml X 1 bottle)
Buffer BE	10 ml X 1 bottle
DGT Column	50 pieces X 2 bags
Collection Tube	50 pieces X 2 bags

Applications

- Gene cloning
- Real time PCR
- SNP genotyping
- Southern blotting

Required Materials

- RNase A (50 mg/ml)
- Absolute ethanol
- Liquid nitrogen
- Chloroform
- Mortar and pestle
- Water bath/Dry bath
- Isopropanol
- Microcentrifuge tubes
- Proteinase K (20 mg/ml) (optional)

Quality Control

The quality of the Dual Genomic DNA Isolation Kit (Tissue) is tested on a lot-to-lot basis to ensure consistent product quality.

Genomic DNA Isolation Kit (Fresh Tissue)

Cat No.	Size	Sample: 30 mg of fresh animal tissue Format: Spin column	Column capacity: Up to 50 µg Operation time: Within 60 minutes
NA026-0100	100 Reactions		
SN026-0100	100 Reactions		

Features

- Ready-to-use genomic DNA for high performance in any downstream application.
- Optimized lysis buffer for the efficient lysis.
- Rapidly purify high-quality DNA using spin column format.

Description

The Genomic DNA Isolation Kit (Fresh Tissue) is designed specifically for genomic DNA isolation from animal tissue samples. This unique buffer system ensures total DNA with high yield and good quality from samples. The spin column system is designed to purify and concentrate DNA samples which have been previously isolated using buffers. The entire procedure can be completed in one hour without phenol/chloroform extraction. Purified DNA is suitable for PCR or other enzymatic reactions.

Kit Contents

Contents	Size
Buffer TL	35 ml X 1 vial
Buffer TP	15 ml X 1 vial
Buffer W1	45 ml X 1 vial
Buffer W2 (Add ethanol)	15 ml X 1 vial (60 ml X 1 vial)
Buffer BE	10 ml X 1 vial
TC Column	50 pieces X 2 bags
Collection Tube	50 pieces X 2 bags

Applications

- Gene cloning.
- PCR.
- Southern blotting.
- SNP genotyping.

Required Materials

- Proteinase K (10 mg/ml)
- Water bath/ Dry bath
- Absolute ethanol
- Mortar and pestle or micropestle
- RNase A (50 mg/ml) (Optional)
- Isopropanol
- Ethanol (96-100%)
- 1.5 ml microcentrifuge tubes

Quality Control

The quality of the Genomic DNA Isolation Kit (Fresh Tissue) is tested on a lot-to-lot basis to ensure consistent product quality.

NUCLEIC ACID PURIFICATION SYSTEM

Genomic DNA Isolation Kit (Paraffin-embedded tissue)

Cat No.	Size	Sample: 25 mg of paraffin-embedded tissue Format: Spin column	Column capacity: Up to 50 µg Operation time: Within 60 minutes
NA027-0100	100 Reactions		
SN027-0100	100 Reactions		

Features

- Ready-to-use genomic DNA for high performance in any downstream application.
- Optimized lysis buffer for the efficient lysis.
- Designed to rapidly purify high-quality DNA using spin column format.

Description

The Genomic DNA Isolation Kit (Paraffin-embedded tissue) is designed specifically for genomic DNA isolation from animal tissue samples. This unique buffer system ensures total DNA with high yield and good quality from samples. The spin column system is designed and purified or concentrate DNA products which have been previously isolated using buffers. The entire procedure can be completed in one hour without phenol/ chloroform extraction. The isolated DNA is suitable for PCR or other enzymatic reactions.

Applications

- Gene cloning.
- PCR.
- Southern blotting.
- SNP genotyping.

Required Materials

- Mortar and pestle
- Proteinase K (10 mg/ml)
- Microcentrifuge tubes
- RNase A (50 mg/ml) (Optional)
- Water bath/Dry bath
- Isopropanol
- Micropestle

Kit Contents

Contents	Size
Buffer TL	35 ml X 1 vial
Buffer TP	15 ml X 1 vial
Buffer W1	45 ml X 1 vial
Buffer W2	15 ml X 1 vial
(Add ethanol)	(60 ml X 1 vial)
Buffer BE	10 ml X 1 vial
TC Column	50 pieces X 2 bags
Collection Tube	50 pieces X 2 bags

- Absolute ethanol
- Xylene

Quality Control

The quality of the Genomic DNA Isolation Kit (Paraffin-embedded tissue) is tested on a lot-to-lot basis to ensure consistent product quality.

DUAL Genomic DNA Isolation Kit (Blood/Cultured Cell/Fungus)

Cat No.	Size	Sample: Up to 300 µl of the whole blood Up to 200 µl of the frozen blood Up to 200 µl of the buffy coat Cultured animal cells (up to 1 x 10 ⁷) Cultured bacterial cells (up to 1 x 10 ⁹) Fungus cells (up to 5 x 10 ⁸)	Format: Reagent and spin column Yield: Up to 50 µg Operation time: Within 60 minutes Elution volume: 50-200 µl
NA015-0100	100 Reactions		
SN015-0100	100 Reactions		

Features

- Fast, reproducible and easy processing by using reagent or spin column system.
- Isolated genomic DNA is compatible with various downstream applications.
- To isolate high quality genomic DNA.

Description

The DUAL Genomic DNA Isolation Kit (Blood/Cultured Cell/Fungus) is designed to combine the reagent system and spin column system. The kit could be used to isolate the genomic DNA from the whole blood, frozen blood, buffy coat, cultured animal/ bacterial cells, and fungus. This unique reagent system ensures the DNA with a high yield and good quality from the samples. The spin column system is designed to purify or concentrate DNA products which have been previously isolated with the reagents. The entire procedure can be completed in 1 hour without the phenol/ chloroform extraction. The purified DNA is suitable for use in PCR or other enzymatic reactions.

Applications

- Restriction enzyme digestion.
- PCR amplification.
- Southern blotting.
- Real-Time PCR assay .

Required Materials

- Microcentrifuge tubes
- RNase A (10 mg/ ml)
- Absolute ethanol
- Lyticase or zymolase (for fungus)
- Isopropanol
- β-mercaptoethanol
- Water bath/Dry bath

Kit Contents

Contents	Size
Buffer RL	100 ml X 1 bottle
Buffer CL	35 ml X 1 bottle
Buffer P0	12 ml X 1 bottle
Buffer BD	45 ml X 1 bottle
Buffer W1	45 ml X 1 bottle
Buffer W2	15 ml X 1 bottle
(Add ethanol)	(60 ml X 1 bottle)
Buffer BE	10 ml X 1 bottle
DG Column	50 pieces X 2 bags
Collection Tube	50 pieces X 2 bags

Quality Control

The quality of the DUAL Genomic DNA Isolation Kit (Blood/Cultured Cell/Fungus) is tested on a lot-to-lot basis to ensure consistent product quality.

NUCLEIC ACID PURIFICATION SYSTEM

Genomic DNA Isolation Kit (Blood/Cultured Cell/Fungus)

Cat No.	Size	Sample: 300 µl of the whole blood 200 µl of the buffy coat Mammalian cells (up to 1x10 ⁷) Fungus cells (up to 1x10 ⁹) Bacterial cells (up to 1x10 ⁹)	Format: Spin column Column capacity: Up to 50 µg Operation time: Within 60 minutes
NA023-0100	100 Reactions		
SN023-0100	100 Reactions		

Features

- Fast procedure and delivering high-quality genomic DNA.
- Ready-to-use genomic DNA for high performance in any downstream application.
- Highly purified and high yield genomic DNA can be extracted from various samples.
- Designed to rapidly purify high-quality DNA using spin column format.
- Optimized lysis buffer for the efficient lysis.

Description

The Genomic DNA Isolation Kit (Blood/Cultured Cell/Fungus) is designed specifically for genomic DNA isolation from the whole blood, frozen blood, buffy coat, cultured animal/bacterial cells and fungus. This unique buffer system ensures genomic DNA with high yield and good quality from samples. The spin column is designed to purify or concentrate genomic DNA products which have been previously isolated using buffers. The entire procedure can be completed in 1 hour without phenol/chloroform extraction. Purified genomic DNA is suitable for use in PCR or other enzymatic reactions.

Applications

- Gene cloning.
- Southern blotting.
- PCR.
- SNP genotyping.

Required Materials

- Microcentrifuge tubes
- Absolute ethanol
- RNase A (10 mg/ml)

Kit Contents

Contents	Size
Buffer CR	100 ml X 1 bottle
Buffer CC	35 ml X 1 bottle
Buffer CB	45 ml X 1 bottle
Buffer W1	45 ml X 1 bottle
Buffer W2 (Add ethanol)	15 ml X 1 bottle (60ml X 1 bottle)
Buffer BE	10 ml X 1 bottle
CC Column	50 pieces X 2 bags
Collection Tube	50 pieces X 2 bags

Quality Control

The quality of the Genomic DNA Isolation Kit (Blood/Cultured Cell/Fungus) is tested on a lot-to-lot basis to ensure consistent product quality.

Genomic DNA Isolation Kit (Blood/ Cultured Cell)

Cat No.	Size	Sample: Up to 200 µl of whole blood, Up to 200 µl of buffy coat, Up to 200 µl of plasma, Up to 200 µl of serum, Up to 200 µl of body fluids, Up to 5x10 ⁶ lymphocytes Up to 5X 10 ⁶ cultured cells, Up to 5x10 ⁶ of bacterial cells	Format: Spin column Yield: Up to 50 µg Operation time: Within 60 minutes Elution volume: 50-200 µl
NA028-0100	100 Reactions		
SN028-0100	100 Reactions		

Features

- Delivering high-quality genomic DNA with the fast procedure
- Ready-to-use genomic DNA for high performance in any downstream application
- Highly purified and high yield genomic DNA can be extracted from various samples
- Optimized lysis buffer for the efficient lysis
- Designed to rapidly purify high-quality DNA using spin column format

Description

The spin-column based Genomic DNA Isolation Kit (Blood/ Cultured Cell) was designed specifically for genomic DNA isolation from whole blood, frozen blood, buffy coat, cultured animal and bacterial cells. Its unique buffer system ensures genomic DNA with high yield and good quality from samples while the spin column purifies and concentrates genomic DNA products previously isolated with the buffer system. The entire procedure can be completed in 1 hour without phenol/chloroform extraction needs. Purified genomic DNA is suitable for use in PCR or other enzymatic reactions.

Applications

- Gene cloning
- PCR
- SNP genotyping

Required Materials

- Microcentrifuge tubes
- Absolute ethanol
- RNase A (10 mg/ml)

Quality Control

The quality of the Genomic DNA Isolation Kit (Blood/Cultured Cell) is tested on a lot-to-lot basis to ensure consistent product quality.

Kit Contents

Contents	Size
Buffer CK	25 ml
Buffer W1	45 ml
Buffer W2 (Add ethanol)	15 ml (60 ml)
Buffer BE	10 ml
Column CC	2 X 50 pcs / pk
Collection Tubes	2 X 50 pcs / pk
Proteinase K (Add ddH ₂ O)	40 mg (2 ml)

NUCLEIC ACID PURIFICATION SYSTEM

MBead Buffy Coat Genomic DNA Kit

Cat No.	Size	Sample: Up to 300 µl of the buffy coat Format: Magnetic Bead System	Operation time: 10-15 minutes Release volume: 200 µl
NA008-0100	100 Reactions		
SN008-0100	100 Reactions		

Features

- Fast, reproducible, and easy processing using a magnetic bead system.
- Recovered genomic DNA is compatible with various downstream applications.
- Isolate high quality genomic DNA.

Description

This magnetic bead genomic DNA purification kit was specifically designed to isolate the genomic DNA from the Buffy Coat. Its unique buffer system will efficiently lyse cells and degrade proteins, allowing for the DNA to be easily bound by the surface of the magnetic beads. The RNA and other non-specific binding particles are removed with a wash buffer, and the genomic DNA is then released into the Release Buffer. The genomic DNA can be purified manually within 10-15 minutes (using most magnetic separators) or the kit can be easily adapted to satisfy most automated nucleic acid purification systems.

Kit Contents

Contents	Size
Magnetic Bead	2 ml X 1 vial
Lysis Buffer	30 ml X 1 bottle
Wash Buffer	80 ml X 1 bottle
Release Buffer	20 ml X 1 bottle

Applications

- Restriction Enzyme Digestion.
- PCR amplification.
- Southern Blotting.
- Real-Time assay.

Required Materials

- Absolute ethanol
- 1.5 ml microcentrifuge tubes
- Magnetic separator
- Water bath/Dry bath

Quality Control

The quality of the MBead Buffy Coat Genomic DNA Kit is tested on a lot-to-lot basis to ensure consistent product quality.

MBead Tissue Genomic DNA Kit

Cat No.	Size	Sample: Up to 30 mg of the animal tissue Format: Magnetic Bead System	Operation time: Within 50 minutes Release volume: 200 µl
NA009-0100	100 Reactions		
SN009-0100	100 Reactions		

Features

- Fast, reproducible and easy processing by using a magnetic bead system
- Isolated genomic DNA is compatible with various downstream applications.
- To isolate high quality genomic DNA.

Description

This MBead Tissue Genomic DNA Kit is designed specifically for isolating the genomic DNA from animal tissue samples. Its unique buffer system will efficiently lyse cells and degrade proteins, allowing for the DNA to be easily bound by the surface of the magnetic beads. The RNA and other non-specific binding particles are removed with a wash buffer, and the genomic DNA is then released in the Release Buffer. The genomic DNA can be purified manually within 50 minutes (using most magnetic separators) or the kit can be easily adapted to satisfy most automated nucleic acid purification systems.

Kit Contents

Contents	Size
Magnetic Bead	2 ml X 1 vial
Grind Buffer	40 ml X 1 bottle
Lysis Buffer	30 ml X 1 bottle
Wash Buffer	80 ml X 1 bottle
Release Buffer	20 ml X 1 bottle

Applications

- Restriction enzyme digestion.
- PCR amplification.
- Southern blotting.
- Real-Time PCR assay.

Required Materials

- Tissue homogenizer (mortar and pestle)
- 1.5 ml microcentrifuge tubes
- Magnetic separator
- Proteinase K (10 mg/ml)
- Absolute ethanol
- Water bath/Dry bath

Quality Control

The quality of the MBead Tissue Genomic DNA Kit is tested on a lot-to-lot basis to ensure consistent product quality.

NUCLEIC ACID PURIFICATION SYSTEM

MBead Bacteria Genomic DNA Kit

Cat No.	Size	Sample: Up to 300 µl of the bacteria culture Format: Magnetic Bead System	Operation time: Within 15-20 minutes Release volume: 200 µl
NA010-0100	100 Reactions		
SN010-0100	100 Reactions		

Features

- Fast, reproducible, and easy processing with using a magnetic bead system.
- Isolated genomic DNA is compatible with various downstream applications.
- To isolate high quality genomic DNA.

Description

The MBead Bacteria Genomic DNA Kit is designed to provide a fast, simple, and cost-effective method for isolating the genomic DNA from bacterial cells. Its unique buffer system will efficiently lyse cells and degrade proteins, allowing for DNA to be easily bound by the surface of the magnetic beads. The Phenol extraction and ethanol precipitation are not required, and the high-quality genomic DNA is released in the Release Buffer. The genomic DNA purified with the MBead Bacteria Genomic DNA Kit is suitable for a variety of applications. The entire procedure can be completed within 15-20 minutes (using most magnetic separators) or the kit can be easily adapted to satisfy most automated Nucleic Acid purification systems.

Kit Contents

Contents	Size
Magnetic Bead	2 ml X 1 vial
Lysis Buffer	30 ml X 1 bottle
Wash Buffer	80 ml X 1 bottle
Release Buffer	20 ml X 1 bottle

Applications

- Restriction enzyme digestion.
- PCR amplification.
- Southern blotting.
- Real-Time PCR assay.

Required Materials

- Absolute ethanol
- 1.5 ml microcentrifuge tubes
- Magnetic separator
- Water bath/Dry bath

Quality Control

The quality of the MBead Bacteria Genomic DNA Kit is tested on a lot-to-lot basis to ensure consistent product quality.

MBead Plant Genomic DNA Kit

Cat No.	Size	Sample: Up to 100 mg of the fresh plant tissue Up to 50 mg of the dry plant tissue Format: Magnetic Bead System	Operation time: Within 50 minutes Release volume: 200 µl
NA012-0100	100 Reactions		
SN012-0100	100 Reactions		

Features

- Fast, reproducible and easy processing by using a magnetic bead system.
- Isolated genomic DNA is compatible with various downstream applications.
- To isolate high quality genomic DNA.

Description

This MBead Plant Genomic DNA Kit is designed specifically for isolating the genomic DNA from plant samples. Its unique buffer system will efficiently lyse cells and degrade proteins, allowing for the DNA to be easily bound by the surface of the magnetic beads. The RNA and other non-specific binding particles are removed with a wash buffer, and the genomic DNA is then released into the Release Buffer. The genomic DNA can be purified manually within 50 minutes (using most magnetic separators) or the kit can be easily adapted to satisfy most automated nucleic acid purification systems.

Kit Contents

Contents	Size
Magnetic Bead	2 ml X 1 vial
Grind Buffer	40 ml X 1 bottle
Lysis Buffer	30 ml X 1 bottle
Wash Buffer	80 ml X 1 bottle
Release Buffer	20 ml X 1 bottle

Applications

- Restriction enzyme digestion.
- Real-Time PCR assay.
- Southern blotting.
- PCR amplification.

Required Materials

- Tissue homogenizer (mortar and pestle)
- Liquid nitrogen
- Isopropanol
- Magnetic separator
- 1.5 ml microcentrifuge tubes

Quality Control

The quality of the MBead Plant Genomic DNA Kit is tested on a lot-to-lot basis to ensure consistent product quality.

NUCLEIC ACID PURIFICATION SYSTEM

MBead Blood Genomic DNA Kit

Cat No.	Size	Sample: Up to 300 µl of the blood Format: Magnetic Bead System	Operation time: Within 10-15 minutes Release volume: 200 µl
NA013-0100	100 Reactions		
SN013-0100	100 Reactions		

Features

- Fast, reproducible and easy processing by using a magnetic bead system.
- Isolated genomic DNA is compatible with various downstream applications.
- To isolate high quality genomic DNA.

Description

This MBead Blood Genomic DNA Kit is designed specifically for isolating the genomic DNA from the blood samples. Its unique buffer system will efficiently lyse cells and degrade proteins, allowing for the DNA to be easily bound by the surface of the magnetic beads. The RNA and other non-specific binding particles are removed with a wash buffer, and the genomic DNA is then released into the Release Buffer. The genomic DNA can be purified manually within 10-15 minutes (using most magnetic separators) or the kit can be easily adapted to satisfy most automated nucleic acid purification systems.

Kit Contents

Contents	Size
Magnetic Bead	2 ml X 1 vial
Lysis Buffer	30 ml X 1 bottle
Wash Buffer	80 ml X 1 bottle
Release Buffer	20 ml X 1 bottle

Applications

- Restriction enzyme digestion.
- PCR amplification.
- Southern blotting.
- Real-Time PCR assay.

Required Materials

- 1.5 ml microcentrifuge tubes
- Magnetic separator
- Absolute ethanol
- Water bath/Dry bath

Quality Control

The quality of the MBead Blood Genomic DNA Kit is tested on a lot-to-lot basis to ensure consistent product quality.

Virus Nucleic Acid Isolation Kit

Cat No.	Size	Sample: Up to 200 µl of virus sample Format: Reagent and mini spin column Sample material: Serum, plasma, body fluids	Operation time: 20 minutes Elution volume: 50 µl
NA016-0100	100 Reactions		
SN016-0100	100 Reactions		

Feature

- High binding capacity for viral RNA or viral DNA.

Description

The Virus Nucleic Acid Isolation Kit provides a fast, simple, and cost-effective method for the isolation of viral DNA/RNA from cell-free samples such as serum, plasma, body fluids and the supernatant of virus-infected cell cultures. Its unique buffer system will efficiently lyse cells and degrade proteins, allowing for the nucleic acid to be easily bound by the glass fiber matrix of the column. Contaminants such as salts, metabolites and soluble macromolecular cellular components are removed in the Wash Step. The phenol extraction and ethanol precipitation are not required, and the high-quality nucleic acid is eluted in the RNase-free elution buffer. The viral DNA/RNA isolated with the Total Nucleic Acid Isolation Kit (Virus) is suitable for a variety of routine applications, including the real-time PCR/RT-PCR, automated fluorescent DNA sequencing, PCR, and other enzymatic reactions. The entire procedure can be completed within 15-20 minutes.

Kit Contents

Contents	Size
Buffer V1	45 ml X 1 bottle
Buffer V2 (Add ethanol)	6 ml X 1 bottle (45 ml X 1 bottle)
Buffer W1	45 ml X 1 bottle
Buffer W2 (Add ethanol)	15 ml X 1 bottle (60 ml X 1 bottle)
Buffer RE	10 ml X 1 bottle
VN Columns	50 pieces X 2 bags
Collection Tube	50 pieces X 2 bags

Applications

- Real-time PCR.
- DNA sequencing.
- Enzymatic reactions.
- RT-PCR.
- PCR.

Required Materials

- Absolute ethanol
- Microcentrifuge tubes (DNase and RNase free)
- PBS (Phosphate Buffered Saline)

Quality Control

The quality of the Virus Nucleic Acid Isolation Kit is tested on a lot-to-lot basis to ensure consistent product quality.

NUCLEIC ACID PURIFICATION SYSTEM

MBead Virus Nucleic acid Kit

Cat No.	Size	Sample: Up to 300 µl of the virus sample Format: Magnetic Bead System	Operation time: Within 10-15 minutes Release volume: 200 µl
NA011-0100	100 Reactions		
SN011-0100	100 Reactions		

Features

- Fast, reproducible and easy processing by using a magnetic bead system.
- Isolated genomic DNA is compatible with various downstream applications.
- To isolate high quality nucleic acid.

Description

This MBead Virus Nucleic acid Kit is designed specifically for the simultaneous virus DNA/RNA purification from the plasma, serum, body fluid or supernatant of virus-infected cell cultures. Its unique buffer system will efficiently lyse cells and degrade proteins, allowing for the nucleic acid to be easily bound by the surface of the magnetic beads. The other non-specific binding particles are removed with a wash buffer, and the nucleic acid is released into the Release Buffer. The nucleic acid can be purified manually within 10-15 minutes (using most magnetic separators) or the kit can be easily adapted to satisfy most automated nucleic acid purification systems.

Kit Contents

Contents	Size
Magnetic Bead	2 ml X 1 vial
Lysis Buffer	30 ml X 1 bottle
Wash Buffer	80 ml X 1 bottle
Release Buffer	20 ml X 1 bottle

Applications

- Restriction enzyme digestion.
- PCR amplification.
- Real-Time PCR assay.

Required Materials

- Absolute ethanol
- 1.5 ml microcentrifuge tubes
- Magnetic separator
- Water bath/Dry bath

Quality Control

The quality of the MBead Virus Nucleic acid Kit is tested on a lot-to-lot basis to ensure consistent product quality.

Plasmid *mini*PREP Kit

Cat No.	Size	Sample: Up to 1.5 ml of bacterial cells Format: column form Operation time: 15-20 minutes Elution volume: 50-200 µl
NA005-0100	100 Reactions	
NA005-0300	300 Reactions	
SN005-0100	100 Reactions	

Features

- Ready-to-use DNA for high performance in any downstream application.
- Consistent DNA yields from a small amount of the starting material.
- Time flexibility.

Description

The Plasmid *mini*PREP Kit provides a fast, simple, and cost-effective method for the plasmid DNA isolation from the cultured bacterial cells. The Plasmid *mini*PREP Kit is based on the alkaline lysis of bacterial cells, followed by the binding of the DNA onto the glass fiber matrix of the spin column in the presence of high salt. The phenol extraction and ethanol precipitation are not required, and the high-quality plasmid DNA is eluted in a small volume of Tris buffer (included in the kit) or water (pH between 7.0 and 8.5, not provided in the kit). The plasmid DNA purified with the Plasmid *mini*PREP Kit is suitable for a variety of routine applications including restriction enzyme digestion, sequencing, library screening, in vitro translation, transfection of robust cells, ligation, and transformation. The entire procedure can be completed within 15-20 minutes.

Kit Contents

Contents	Size (100 rxns)	Size (300 rxns)
Buffer S1	25 ml X 1 bottle	65 ml X 1 bottle
Buffer S2	25 ml X 1 bottle	65 ml X 1 bottle
Buffer S3	35 ml X 1 bottle	95 ml X 1 bottle
Buffer W1	45 ml X 1 bottle	125 ml X 1 bottle
Buffer W2	15 ml X 1 bottle	25 ml X 2 bottles
(Add ethanol)	(60 ml X 1 bottle)	(100 ml X 2 bottles)
Buffer BE	10 ml X 1 bottle	30 ml X 1 bottle
RNase A (50mg/mL)	50 µl X 1 vial	150 µl X 1 vial
PM Column	50 pieces X 2 bags	50 pieces X 6 bags
Collection Tube	50 pieces X 2 bags	50 pieces X 6 bags

Applications

- Quantity of DNA needed.
- Molecular weight and size of DNA.
- Purity of DNA required.

Required Materials

- Ethanol (96-100%).
- Microcentrifuge tubes.

Quality Control

The quality of the Plasmid *mini*PREP Kit is tested on a lot-to-lot basis to ensure consistent product quality.

NUCLEIC ACID PURIFICATION SYSTEM

Plasmid *mid*iPREP Kit

Cat No.	Size	Sample: Up to 100 ml bacterial cells Yield: Up to 250 µg of plasmid Endotoxin value: <0.003 EU/µg	Operation time: Within 40 minutes Elution volume: 2 ml
NA205-0020	20 Reactions		
SN205-0020	20 Reactions		

Features

- Ready-to-use DNA for high performance in any downstream application.
- Consistent DNA yields from a small amount of the starting material.
- Time flexibility.

Description

The Plasmid *mid*iPREP Kit provides a fast, simple, and cost-effective method for the plasmid DNA isolation from the cultured bacterial cells. The Plasmid *mid*iPREP Kit is based on the alkaline lysis of bacterial cells, followed by binding DNA onto the glass fiber matrix of the spin column in the presence of high salt. Phenol extraction and ethanol precipitation are not required, and the high-quality plasmid DNA is eluted in a small volume of the Tris buffer (included in each kit) or water (pH is between 7.0 and 8.5). The plasmid DNA purified with the Plasmid *mid*iPREP Kit is suitable for a variety of routine applications, including the restriction enzyme digestion, sequencing, library screening, in vitro translation, transfection of robust cells, ligation, and transformation. The entire procedure can be completed within 40 minutes.

Kit Contents

Contents	Size
Buffer M1	85 ml X 1 bottle
Buffer M2	85 ml X 1 bottle
Buffer M3	125 ml X 1 bottle
Buffer W1	125 ml X 1 bottle, 40 ml X 1 bottle
Buffer W2 (Add ethanol)	25 ml x 2 bottles (100 ml X 2 bottles)
Buffer BE	50 ml X 1 bottle
RNase A (50mg/mL)	200 µl
MD Column	20 pieces X 1 bag

Applications

- Quantity of DNA needed.
- Molecular weight and size of DNA.
- Purity of DNA required.

Required Materials

- Ethanol (96-100%)
- Microcentrifuge tubes
- Swing bucket rotor centrifuge

Quality Control

The quality of the Plasmid *mid*iPREP Kit is tested on a lot-to-lot basis to ensure consistent product quality.

Plasmid *maxi*PREP Kit

Cat No.	Size	Sample: Up to 200 ml bacterial cells Yield: Up to 850 µg of plasmid Endotoxin value: <0.003 EU/µg	Operation time: Within 45 minutes Elution volume: 2 ml
NA305-0010	100 Reactions		
SN305-0010	100 Reactions		

Features

- Ready-to-use DNA for high performance in any downstream application.
- Consistent DNA yields from a small amount of the starting material.
- Time flexibility.

Description

The Plasmid *maxi*PREP Kit provides a fast, simple, and cost-effective method for the plasmid DNA isolation from the cultured bacterial cells. The Plasmid *maxi*PREP Kit is based on the alkaline lysis of bacterial cells, followed by binding DNA onto the glass fiber matrix of the spin column in the presence of high salt. Phenol extraction and ethanol precipitation are not required, and the high-quality plasmid DNA is eluted in a small volume of the Tris buffer (included in each kit) or water (pH is between 7.0 and 8.5). The plasmid DNA purified with the Plasmid *maxi*PREP Kit is suitable for a variety of routine applications, including the restriction enzyme digestion, sequencing, library screening, in vitro translation, transfection of robust cells, ligation, and transformation. The entire procedure can be completed within 40 minutes.

Kit Contents

Contents	Size
Buffer M1	85 ml X 1 bottle
Buffer M2	85 ml X 1 bottle
Buffer M3	125 ml X 1 bottle
Buffer W1	105 ml X 1 bottle
Buffer W2 (Add ethanol)	25 ml x 1 bottles (100 ml X 1 bottles)
Buffer BE	30 ml X 1 bottle
RNase A (50mg/mL)	200 µl
MX Column	10 pieces X 1 bag

Applications

- Quantity of DNA needed.
- Molecular weight and size of DNA.
- Purity of DNA required.

Required Materials

- Ethanol (96-100%)
- Microcentrifuge tubes
- Swing bucket rotor centrifuge

Quality Control

The quality of the Plasmid *maxi*PREP Kit is tested on a lot-to-lot basis to ensure consistent product quality.

NUCLEIC ACID PURIFICATION SYSTEM

PCR Clean-Up & Gel Extraction Kit

Cat No.	Size	Sample: Up to 100 µl of the PCR Product Up to 300 mg of DNA fragment from the agarose gel Format: Column form	Operation time: 15-20 minutes Elution volume: 50-200 µl Recovery: Up to 95%
NA006-0100	100 Reactions		
NA006-0300	300 Reactions		
SN006-0100	100 Reactions		

Features

- Ready-to-use DNA for high performance in any downstream.
- Time flexibility.

Description

The PCR Clean-Up & Gel Extraction Kit provides a fast, easy, and cost-effective system to isolate the DNA fragments from PCR reactions, agarose gels, or enzymatic reactions. The DNA fragments (100bp-10Kb) in the special buffers are bound by the glass fiber matrix of the spin column while contaminants pass through the column. Impurities are efficiently washed away, and the pure DNA is eluted with the Tris buffer or water without phenol extraction or alcohol precipitation. The DNA purified with the kits is suitable for any subsequent application, such as ligation and transformation, sequencing, restriction enzyme digestion, labeling, PCR, in vitro transcription, or microinjection. The entire procedure can be completed within 15-20 minutes.

Kit Contents

Contents	Size (100 rxns)	Size (300 rxns)
Buffer B	60 ml X 1 bottle	80 ml X 2 bottles
Buffer W1	45 ml X 1 bottle	125 ml X 1 bottle
Buffer W2 (Add ethanol)	15 ml X 1 bottle (60 ml X 1 bottle)	25 ml X 2 bottles (100 ml X 2 bottles)
Buffer BE	10 ml X 1 bottle	30 ml X 1 bottle
PG Column	50 pieces X 2 bags	50 pieces X 6 bags
Collection Tube	50 pieces X 2 bags	50 pieces X 6 bags

Applications

- Quantity of DNA needed.
- Purity of DNA required.

Required Materials

- Ethanol (96-100%)
- 1.5 ml microcentrifuge tubes
- Water bath/Dry bath for Gel Extraction protocol needed

Quality Control

The quality of the PCR Clean-Up & Gel Extraction Kit is tested on a lot-to-lot basis to ensure consistent product quality.



PROTEIN ANALYSIS

Protein Ladders

Product Name	Cat. No.	Size	Page
PiNK Plus Prestained Protein Ladder	PM005-0500 / SP005-0500	500 µl	56
BlueRAY Prestained Protein Ladder	PM006-0500 / SP006-0500	500 µl	57
BLUeye Prestained Protein Ladder	PM007-0500 / SP007-0500	500 µl	58
BLUelf Prestained Protein Ladder	PM008-0500 / SP008-0500	500 µl	59
BlueAQUA Prestained Protein Ladder	PM019-0500 / SP019-0500	500 µl	60

Protein Gel Prep. & Stains

Product Name	Cat. No.	Size	Page
EVOgel™	MB803-0100 / SM803-0100	100 ml	61
EVOgel™	MB803-0500 / SM803-0500	500 ml	61
Nimble Juice (Speedy Protein Gel Stain)	NJ001-0010 / SJ001-0010	10 ml	62
Nimble Juice <i>RTYPE</i>	NJ002-0500 / SJ002-0500	500 ml	62
iBlue Protein Stain	SJ003-1000M	1000 ml	63
ECLong	SM801-0500	250 ml X 2	63

Protein Labeling

Product Name	Cat. No.	Size	Page
R-PE Labeling Kit	RPE01-0010	10 µg	64
R-PE Labeling Kit	RPE01-0100	100 µg	64
R-PE (R-Phycoerythrin)	RPE02-1000	1 mg	64
R-PE (R-Phycoerythrin)	RPE02-5000	5 mg	64
SMCC-Activated R-PE	RPE03-1000	1 mg	64
SMCC-Activated R-PE	RPE03-5000	5 mg	64

PROTEIN LADDERS

PiNK Plus Prestained Protein Ladder

Cat No.	Size
PM005-0500	500 µl
SP005-0500	250 µl X 2 vials

Features

- Broad range: 10-175 kDa (Tris-glycine-SDS running buffer)
- Easy to identify: includes the ~10, ~40 and ~90 kDa reference bands coupled with an blue dyes
- Ready-to-use: supplied in a loading buffer for direct loading on gels
- Sharp bands

Description

The PiNK Plus Prestained Protein Ladder contains 11 proteins that resolve into sharp, tight bands in the range of 10-175 kilodalton (kDa). The PiNK Plus Prestained Protein Ladder allows you to monitor molecular weight separation during on SDS polyacrylamide gel electrophoresis (SDS-PAGE), estimate molecular weights of proteins of interest, and evaluate western transfer efficiency.

Applications

- Monitoring of protein migration during SDS-PAGE gel electrophoresis.
- Sizing of proteins on SDS-PAGE gels and Western blots.
- Monitoring of protein transfer onto membranes during Western blots.

Storage Buffer

Approximately 0.2-0.4 mg/ml of each protein in the buffer (20 mM Tris-phosphate, pH 7.5 at 25°C), 2 % SDS, 1 mM Dithiothreitol, 4.8 M Urea, and 12 % (v/v) Glycerol.

Quality Control

The quality of the PiNK Plus Prestained Protein Ladder is tested on a lot-to-lot basis to ensure consistent product quality.

Storage

Stable for up to 2 weeks at 25°C. Stable for up to 3 months at 4°C. For long term storage, store at -20°C.

PiNK Plus Prestained Protein Ladder Protocol

1. Thaw the ladder either at room temperature or at 37-40°C for a few minutes to dissolve precipitated solids. Do not boil.
2. Mix thoroughly to ensure the solution is homogeneous.
3. Load the following volumes of the ladder on SDS-PAGE gel:
 - 5 µl per well for mini-gels, 2.5 µl per well for blots
 - 10 µl per well for large gels, 5 µl per well for blots
 - Apply more for thicker (> 1.5 mm) or larger gel

Guide for Molecular Weight Estimation (kDa)

Migration patterns of PiNK Plus Prestained Protein Ladder in different electrophoresis conditions are listed below:

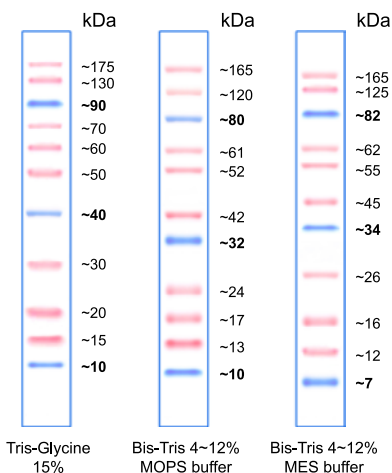

% of migration	Tris Glycine Gel					4-12% Bis Tris Gel		3-8% Tris Acetate	EVOgel
	8 %	10 %	12 %	15 %	4-20 %	MOPS	MES	TA	TG
0 %			175	175	175		165		165
10 %		175	130	130	130		125		125
20 %	175	130	70	70	70	165	82	160	85
30 %	130	90	60	60	60	120	62	115	70
40 %	90	70	50	40	50	80	35	85	60
50 %	70	60	40	30	40	61	45	65	48
60 %	60	50	30	20	30	52	34	55	38
70 %	50	40	20	15	20	42	26	45	25
80 %	40	30	15	10	15	32	16	27	19
90 %	30	20	10	10	10	24	12	18	15
100 %						17	7	15	11

Note:

1. The apparent molecular weight of each protein has been determined by calibration against unstained protein standards
 2. Supplemental data should be considered for more accurate adjustment in different electrophoresis conditions.
- All products are for research use only.

PROTEIN LADDERS

BlueRAY Prestained Protein Ladder

Cat No.	Size
PM006-0500	500 µl
SP006-0500	250 µl X 2 vials

Features

- Broad range: 10-180 kDa (Tris-glycine-SDS running buffer)
- Ready-to-use: supplied in a loading buffer for direct loading on gels
- Sharp bands
- Easy to identify: includes the ~25, ~75 kDa reference bands coupled with a green and a red dye

Description

The BlueRAY Prestained Protein Ladder is a three-color protein standard with 10 prestained proteins covering a wide range molecular weights for 10 to 180 kilodalton (kDa). Proteins are covalently coupled with a blue chromophore except for two reference bands (one green and one red band at 25 kDa and 75 kDa respectively) when separated on SDS-polyacrylamide gel electrophoresis (SDS-PAGE) with Tris-glycine-SDS running buffer. The BlueRAY Prestained Protein Ladder is designed for monitoring protein separated during SDS-PAGE, verification of Western transfer efficiency on membranes (PVDF, nylon or nitrocellulose) and for approximate sizing of proteins. The ladder is supplied in gel loading buffer and is ready to use. Do not heat, dilute, and add reducing agent before loading.

Applications

- Monitoring of protein migration during SDS-PAGE.
- Monitoring of protein transfer onto membranes during Western blots.
- Sizing of proteins on SDS-PAGE gels and Western blots.

Storage Buffer

Approximately 0.2-0.4 mg/ml of each protein in buffer (20 mM Trisphosphate pH 7.5 at 25°C), 2% SDS, 0.2 mM Dithiothreitol, 3.6 M Urea, and 15% (v/v) Glycerol.

Quality Control

The quality of the BlueRAY Prestained Protein Ladder is tested on a lot-to-lot basis to ensure consistent product quality.

Storage

Stable for up to 2 weeks at 25°C. Stable for up to 3 months at 4°C. For long term storage, store at -20°C.

BlueRAY Prestained Protein Ladder Protocol

1. Thaw the ladder either at room temperature or at 37-40°C for a few minutes to dissolve precipitated solids. Do not boil.
2. Mix thoroughly to ensure the solution is homogeneous.
3. Load the following volumes of the ladder on SDS-PAGE gel:
 - 5 µl per well for mini-gels, 2.5 µl per well for blots
 - 10 µl per well for large gels, 5 µl per well for blots
 - Apply more for thicker (> 1.5 mm) or larger gel

Guide for Molecular Weight Estimation (kDa)

Migration patterns of BlueRAY Prestained Protein Ladder in different electrophoresis conditions are listed below:

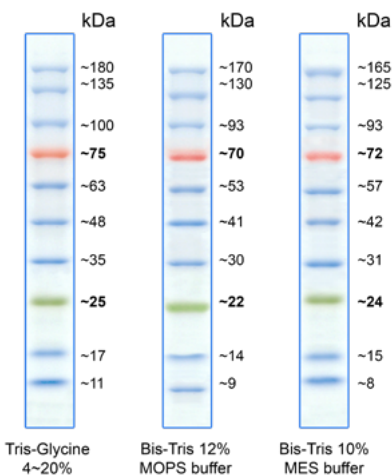

% of migration	Tris Glycine Gel						4-12% Bis Tris Gel		3-8% Tris Acetate	EVOgel	
	6 %	8 %	10 %	12 %	14 %	16 %	4-20 %	MOPS	MES	TA	TG
0 %											
10 %		180	180	180	180	180		170	165		180
20 %		135	135	135	135	135		130	125		135
30 %		100	100	100	100	100		93	93		95
40 %		75	75	75	75	75		70	70	165	70
50 %		63	63	63	63	63		57	57	120	57
60 %		48	48	48	48	48		42	42	100	45
70 %		35	35	35	35	35		31	31	70	36
80 %		25	25	25	25	25		24	24	45	26
90 %		17	17	17	17	17		15	15	30	19
100 %		11	11	11	11	11		8	8	27	10

Note:

1. The apparent molecular weight of each protein has been determined by calibration against an unstained protein ladder in each electrophoresis condition.
 2. Supplemental data should be considered for more accurate adjustment.
- All products are for research use only.

PROTEIN LADDERS

BLUeye Prestained Protein Ladder

Cat No.	Size
PM007-0500	500 µl
SP007-0500	250 µl X 2 vials

Features

- Broad range: 10-245 kDa (Tris-glycine-SDS running buffer)
- Ready-to-use: supplied in a loading buffer for direct loading on gels
- Sharp bands
- Easy to identify: includes the ~25, ~75 kDa reference bands coupled with a green and a red dye

Description

The BLUeye Prestained Protein Ladder is a three-color protein standard with 12 prestained proteins covering a wide range molecular weights from 10 to 245 kilodalton (kDa). Proteins are covalently coupled with a blue chromophore except for two reference bands (one green and one red band at 25 kDa and 75 kDa respectively) when separated on SDS-polyacrylamide gel electrophoresis (SDS PAGE) with Tris-glycine-SDS running buffer. The BLUeye Prestained Protein Ladder is designed for monitoring protein separation during, verification of Western transfer efficiency on membranes (PVDF, nylon, or nitrocellulose) and for approximating the size of proteins. The ladder is supplied in gel loading buffer and is ready to use.

Applications

- Monitoring of protein migration during SDS-PAGE.
- Monitoring of protein transfer onto membranes during Western blots.
- Sizing of proteins on SDS-PAGE gels and Western blots.

Storage Buffer

Approximately 0.1-0.4 mg/ml of each protein in the buffer (20 mM Trisphosphate, pH 7.5 at 25°C), 2 % SDS, 0.2 mM Dithiothreitol, 3.6 M Urea, and 15 % (v/v) Glycerol.

Quality Control

The quality of the BLUeye Prestained Protein Ladder is tested on a lot-to-lot basis to ensure consistent product quality.

Storage

Stable for up to 2 weeks at 25°C. Stable for up to 3 months at 4°C. For long term storage, store at -20°C.

BLUeye Prestained Protein Ladder Protocol

1. Thaw the ladder either at room temperature or at 37-40°C for a few minutes to dissolve precipitated solids. Do not boil.
2. Mix thoroughly to ensure the solution is homogeneous.
3. Load the following volumes of the ladder on SDS-PAGE gel:
 - 5 µl per well for mini-gels, 2.5 µl per well for blots
 - 10 µl per well for large gels, 5 µl per well for blots

Guide for Molecular Weight Estimation (kDa)

Migration patterns of BLUeye Prestained Protein Ladder in different electrophoresis conditions are listed below:

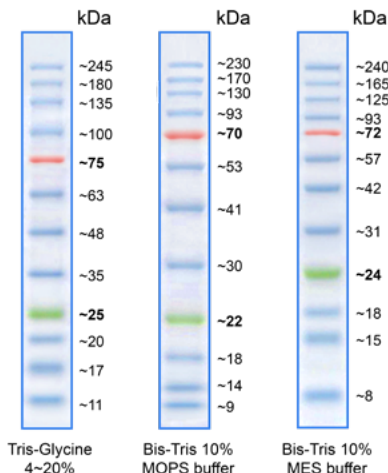

% of migration	Tris Glycine Gel						4-12% Bis Tris Gel		3-8% Tris Acetate	EVOgel	
	6 %	8 %	10 %	12 %	14 %	16 %	4-20 %	MOPS	MES	TA	TG
0 %											
10 %		245	245	245	245	245		240	240		240
20 %		180	180	180	180	180		180	180		180
30 %		135	135	135	135	135		135	135		135
40 %		100	100	100	100	100		100	100		100
50 %		75	75	75	75	75		75	75		75
60 %		53	53	53	53	53		53	53		53
70 %		42	42	42	42	42		42	42		42
80 %		31	31	31	31	31		31	31		31
90 %		24	24	24	24	24		24	24		24
100 %		18	18	18	18	18		18	18		18

Note:

1. The apparent molecular weight of each protein has been determined by calibration against an unstained protein ladder in each electrophoresis condition.
 2. Supplemental data should be considered for more accurate adjustment.
- All products are for research use only.

PROTEIN LADDERS

BLUelf Prestained Protein Ladder

Cat No.	Size
PM008-0500	500 µl
SP008-0500	250 µl X 2 vials

Features

- Broad range: 3.5-245 kDa (Tris-glycine-SDS running buffer)
- Easy to identify: includes the ~25, ~75 kDa reference bands coupled with a green and a red dye
- Ready-to-use: supplied in a loading buffer for direct loading on gels
- Sharp bands

Description

The BLUeye Prestained Protein Ladder is a three-color protein standard with 12 prestained proteins covering a wide range molecular weights from 10 to 245 kilodalton (kDa). Proteins are covalently coupled with a blue chromophore except for two reference bands (one green and one red band at 25 kDa and 75 kDa respectively) when separated on SDS-polyacrylamide gel electrophoresis (SDS PAGE) with Tris-glycine-SDS running buffer. The BLUeye Prestained Protein Ladder is designed for monitoring protein separation during, verification of Western transfer efficiency on membranes (PVDF, nylon, or nitrocellulose) and for approximating the size of proteins. The ladder is supplied in gel loading buffer and is ready to use.

Applications

- Monitoring of protein migration during SDS-PAGE.
- Sizing of proteins on SDS-PAGE gels and Western blots.
- Monitoring of protein transfer onto membranes during Western blots.

Storage Buffer

Approximately 0.1-0.4 mg/ml of each protein in the buffer (20 mM Tris-phosphate, pH 7.5 at 25°C), 2 % SDS, 0.2 mM Dithiothreitol, 3.6 M Urea, and 15 % (v/v) Glycerol.

Quality Control

The quality of the BLUelf Prestained Protein Ladder is tested on a lot-to-lot basis to ensure consistent product quality.

Storage

Stable for up to 2 weeks at 25°C. Stable for up to 3 months at 4°C. For long term storage, store at -20°C.

BLUelf Prestained Protein Ladder Protocol

1. Thaw the ladder either at room temperature or at 37-40°C for a few minutes to dissolve precipitated solids. Do not boil.
2. Mix thoroughly to ensure the solution is homogeneous.
3. Load the following volumes of the ladder on SDS-PAGE gel:
 - 15 µl per well for mini-gels, 2.5 µl per well for blots
 - 10 µl per well for large gels, 5 µl per well for blots
 - Apply more for thicker (> 1.5 mm) or larger gel

Guide for Molecular Weight Estimation (kDa)

Migration patterns of BLUelf Prestained Protein Ladder in different electrophoresis conditions are listed below:

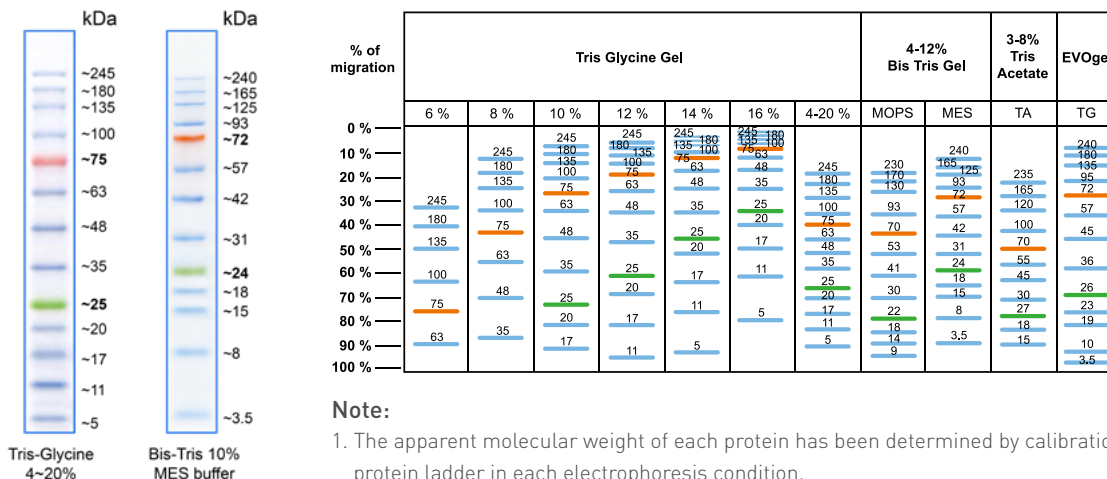

Note:

1. The apparent molecular weight of each protein has been determined by calibration against an unstained protein ladder in each electrophoresis condition.
 2. Supplemental data should be considered for more accurate adjustment.
- All products are for research use only.

PROTEIN LADDERS

BlueAQUA Prestained Protein Ladder

Cat No.	Size
PM019-0500	500 µl
SP019-0500	250 µl X 2 vials

Features

- Broad range: 10-180 kDa (Tris-glycine-SDS running buffer)
- Ready-to-use: supplied in a loading buffer for direct loading on gels
- Sharp bands
- Easy to identify: includes the ~25, ~72 kDa reference bands enhanced the intensity

Description

The BlueAQUA Prestained Protein Ladder is a blue protein standard with 11 prestained proteins covering a wide range of molecular weights from 10 to 180 kilodalton (kDa). Proteins are covalently coupled with a blue chromophore, and two reference bands (at 25 kDa and 72 kDa respectively) are enhanced in intensity when separated on SDS-polyacrylamide gel electrophoresis (SDS-PAGE) with Tris-glycine-SDS running buffer. The BlueAQUA Prestained Protein Ladder is designed for monitoring protein separation during SDS-polyacrylamide gel electrophoresis, verification of Western transfer efficiency on membranes (PVDF, nylon, or nitrocellulose) and for approximating the size of proteins. The ladder is supplied in gel loading buffer and is ready to use. Do not heat, dilute, add reducing agent before loading.

Applications

- Monitoring of protein migration during SDS-PAGE.
- Monitoring of protein transfer onto membranes during Western blots.
- Sizing of proteins on SDS-PAGE gels and Western blots.

Storage Buffer

Approximately 0.1-0.5 mg/ml of each protein in the buffer (20 mM Tris-phosphate, pH 7.5 at 25°C), 2 % SDS, 0.2 mM Dithiothreitol, 3.6 M Urea, and 15 % (v/v) Glycerol).

Quality Control

The quality of BlueAQUA Prestained Protein Ladder is tested on a lot-to-lot basis to ensure consistent product quality.

Storage

Stable for up to 2 weeks at 25°C. Stable for up to 3 months at 4°C. For long term storage, store at -20°C.

BlueAQUA Prestained Protein Ladder Protocol

1. Thaw the ladder either at room temperature or at 37-40°C for a few minutes to dissolve precipitated solids. Do not boil.
2. Mix thoroughly to ensure the solution is homogeneous.
3. Load the following volumes of the ladder on SDS-PAGE gel:
 - 5 µl per well for mini-gels, 2.5 µl per well for blots
 - 10 µl per well for large gels, 5 µl per well for blots
 - Apply more for thicker (> 1.5 mm) or larger gel

Guide for Molecular Weight Estimation (kDa)

Migration patterns of BlueAQUA Prestained Protein Ladder in different electrophoresis conditions are listed below:

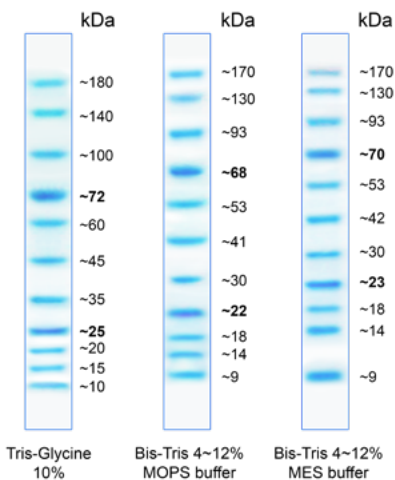

% of migration	Tris Glycine Gel				4-12% Bis Tris Gel		3-8% Tris Acetate	EVOgel	
	8 %	10 %	12 %	15 %	4-20 %	MOPS	MES	TA	TG
0 %			180	180					
10 %		180	140	100					180
20 %	180	140	72	60					135
30 %	140	100	60	45					95
40 %	100	72	45	35	180	170	165	165	72
50 %	72	60	35	25	140	130	120	120	57
60 %	60	45	25	20	100	93	70	70	45
70 %	45	35	20	15	72	68	53	55	35
80 %				10	60	53	42	45	
90 %					45	30	23	30	
100 %					35	23	18	18	
					25	18	14	14	
					20	14	11	11	
					18	11	9	9	
					14	9	7	7	
					10	7	5	5	

Note:

1. The apparent molecular weight of each protein has been determined by calibration against an unstained protein ladder in each electrophoresis condition.
 2. Supplemental data should be considered for more accurate adjustment.
- All products are for research use only.

PROTEIN GEL PREP. & STAINS

EVOgel™

Cat No.	Size
MB803-0100	100 ml
MB803-0500	500 ml
SM803-0100	100 ml
SM803-0500	500 ml

Features

- High gel strength – allows easier handling
- Ready to use in less than 10-15 minutes – just add TEMED and ammonium persulfate to polymerize the gel
- No stacking gel required – permits longer gel separations
- High resolution gels for protein separation across a broad molecular weight range

Traditional Materials

Acrylamide
Tris HCl
SDS
TEMED
APS



1 hour

EVOLUTION

EVOgel™ Protocol

Only add

- TEMED
- APS



Only 15 mins

Description

EVOgel™, evolutionary SDS polyacrylamide solution, polymerize into an advanced molecular sieve for the electrophoretic separation of proteins. Because of the advanced buffer chemistry used in the gel matrix solution, EVOgel™ allows a single separating gel. Band resolution is unparalleled over a molecular range of 2.5 to 250 kDa. The new hybrid formulation of EVOgel™ gives these gels an increased gel strength, which allows for easier handling. EVOgel™ will work with all types of universal electrophoresis apparatus. Our gel mixtures are formulated for optimal performance in mass spectrometry-based proteomics experiments.

Applications

- Western blotting
- Gel staining
- Mass spectrometry-based proteomics experiments

Required Materials

- Saran wrap
- Safety light
- Cassette

Quality Control

The quality of the EVOgel™ is tested on a lot-to-lot basis to ensure consistent product quality.

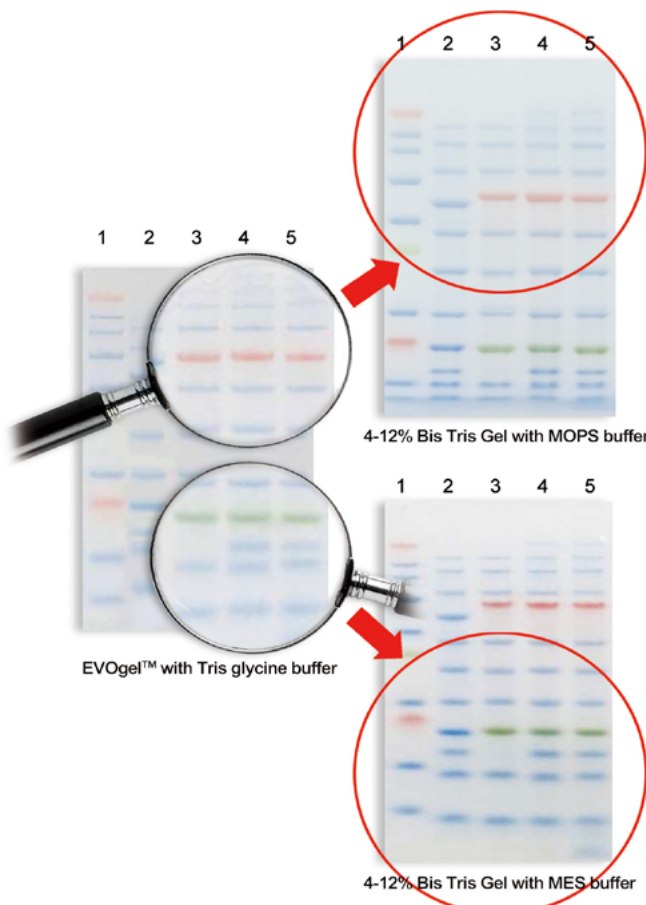

Lane 1: BLUtra Prestained Protein Ladder
Lane 2: BlueAQUA Prestained Protein Ladder
Lane 3: BlueRAY Prestained Protein Ladder
Lane 4: BLUeye Prestained Protein Ladder
Lane 5: BLUelf Prestained Protein Ladder

The pattern of EVOgel™ compares with 4-12% Bis Tris Gel.

PROTEIN GEL PREP. & STAINS

Nimble Juice Speedy Protein gel stain

Cat No.	Size
NJ001-0010	10 ml
SJ001-0010	10 ml

Description

Nimble Juice is a fast and sensitive fluorescent dye for visualization and quantitation of proteins separated by 1-D or 2-D SDS-PAGE. It comes as a 100x stock solution that is simply diluted with water by the user to its working concentration. Nimble Juice is normally low fluorescent but emits strong fluorescence (bright golden color) as bound to proteins. The staining procedure is a simple two-step protocol (fix and stain) that can be completed in as little as 30 minutes. Gels to be stained are fixed with ethanol/acetic acid solution prior to staining with Nimble Juice solution. A destain step is not normally recommended, but may be employed to reduce background, simply by agitating the gel in water for 1-5 minutes. Gels stained with Nimble Juice fluorescent gel stain may be directly visualized with a variety of different UV-based fluorescence imaging systems. The maximum emission wavelength of protein-bound Nimble Juice is near 570 nm. Nimble Juice gives exceptional sensitivity and wide dynamic range for protein detection. The bound Nimble Juice dye is easily removed from the protein by immersing the gel in sufficient water, thus it is well compatible with subsequent enzymatic digestion and mass spectrometry for proteomics applications. Stained gels may be stored in stain solution in the dark at 2-8°C; imaging sensitivity might be moderately enhanced after 4°C storage of the stained gel.

Equipment Required but Not Supplied

1. Staining containers—Glass trays are recommended.
2. Imaging equipment — Gels are best imaged using a UV-based fluorescence imager capable of excitation near 330 nm and 390 nm and detection near 570 nm.
3. Laboratory shaker or rocker.
4. Powder-free latex, vinyl, or nitrile gloves.

Reagents Required but not Supplied

1. Acetic Acid, reagent grade.
2. Ethanol, reagent grade.
3. Filtered, distilled or deionized water.

Nimble Juice *R*TYPE

Cat No.	Size
NJ002-0500	500 ml
SJ002-0500	500 ml



Description

Nimble Juice *R*TYPE is a fast and sensitive fluorescent dye for visualization and quantitation of proteins separated by SDS-PAGE. It comes as a 1x solution that is ready to use at the working concentration. Nimble Juice *R*TYPE is normally low fluorescent but emits strong fluorescence (bright golden color) when bound to proteins. The staining procedure is a simple two-step protocol (microwave and stain) that can be completed in as little as 12 minutes. During the experiment, it doesn't require organic solvents and acetic acid. A destaining step is not generally recommended, but may be employed to reduce the background, simply by agitating the gel in water for 1-5 minutes. Gels stained with the Nimble Juice *R*TYPE may be directly visualized with a variety of different UV-based fluorescence imaging systems. The maximum emission wavelength of the protein-bound Nimble Juice *R*TYPE is near 570 nm. Nimble Juice *R*TYPE gives exceptional sensitivity and a wide dynamic range for protein detection. The bound Nimble Juice *R*TYPE dye is easily removed from the protein by immersing the gel in sufficient water, thus it is well compatible with subsequent enzymatic digestion and mass spectrometry for proteomic applications. The stained gels may be stored in the stain solution in dark at 2-8°C.

Fluorescence Characteristics

Nimble Juice *R*TYPE has its excitation peaks at 330 and 390 nm and emission maximum at 570 nm, making it compatible with UV-based imagers.

Sensitivity of Nimble Juice *R*TYPE

The Nimble Juice *R*TYPE is highly sensitive, and the amount of proteins required to be visualized by Nimble Juice *R*TYPE is much less than what is needed for using the conventional coomassie blue stain. The Nimble Juice *R*TYPE exhibits a more optimal staining effect than the coomassie blue staining method while takes relatively less time than the coomassie blue. The limit of sensitivity for individual proteins is around 20 ng or less.

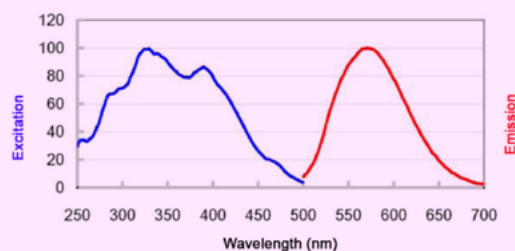

Protein Markers Suitable for Nimble Juice *R*TYPE

Molecular weight standards that have been prestained with a visible dye do not stain with Nimble Juice *R*TYPE thus cannot be imaged by fluorescence in gels stained with Nimble Juice *R*TYPE. We recommend the use of unstained protein standards as the alternative for Nimble Juice *R*TYPE.

PROTEIN GEL PREP. & STAINS

iBlue Protein Stain

Cat No.	Size
SJ003-1000M	1000 ml

Features

- Ready to use format.
- Time efficiency – Result in 15 minutes.
- One step process – No wash, fix, and destain process.
- Safe composition – Nontoxic, no fume hood or solvent disposal required.
- Mass spectrometry compatible – Destainable. No residual methylation or acetylation.

Description

The iBlue is a ready-to-use reagent, proprietary Coomassie stain that is ultra-fast, sensitive, and safe detection of protein samples. Protein gels can be stained in minutes without wash, fix, and destain. The iBlue provides a result in a low background interference and better signal to noise ratio and may also have a positive impact on the overall resolution and sensitivity. The iBlue formulation is non-toxic and does not contain methanol. Proteins stained using the iBlue stain are also compatible with mass spectrometry (MS) analysis. Subsequent enzymatic digestion and mass spectrometry for proteomics applications. Stained gels may be stored in stain solution in the dark at 2-8°C; imaging sensitivity might be moderately enhanced after 4°C storage of the stained gel.

Required Materials

- Staining container
- For gel drying:
 - 100 ml of ultrapure water
 - Microwave
 - Gel drying solution: 4% glycerol, 20% ethanol in water
 - Cellophane membranes
- Shaker
- For MS analysis:
 - Microcentrifuge tubes
 - Destain solution: 30% ethanol, 30% acetone, or 30% acetic acid
 - Dry bath (optional)

Quality Control

The quality of the iBlue Protein Stain is tested on a lot-to-lot basis to ensure consistent product quality.

ECLong

Cat No.	Size
SM801-0500	250 ml X 2

Features

- Signal Duration: 12 hours
- Suggested Antibody Dilution:
 - Primary: 1/1,000 – 1/50,000
 - Secondary: 1/50,000 – 1/250,000
- Detection Method: X-ray film or imaging acquisition system
- Lower Detection Limit:
 - Low-Picogram (10^{-14})
 - High-zeptomole (10^{-19})

Description

The principle of ECLong is based on chemiluminescence and is very convenient to detect the Horseradish peroxidase (HRP) activity in many assays such as Western blotting, Southern blotting, and Northern blotting. HRP catalyzes the chemiluminescent oxidation of cyclic diacylhydrazides such as luminol by hydrogen peroxide (H_2O_2). ECLong can enhance the luminol-dependent chemiluminescence and be widely used to detect the present of HRP-conjugated antibodies or streptavidin which binding to antigen or nucleotide sequence respectively.

Kit Contents

Contents	Size
Reagent A	250 ml
Reagent B	250 ml

Application

- Western blotting

Required Materials

- Saran wrap
- Safety light
- Cassette

Quality Control

The quality of the ECLong is tested on a lot-to-lot basis to ensure consistent product quality.

PROTEIN LABELING

R-PE Labeling Kit

Product Overview

Simply® R-PE labeling kit allows you to quickly add the label onto highly-specific antibody of your choice with simple steps, less hands-on time, and without the risk of sample loss. Applications are various from cell isolation i.e. in Circulating Tumor Cell research, to development of new antibody.

Easy to prepare

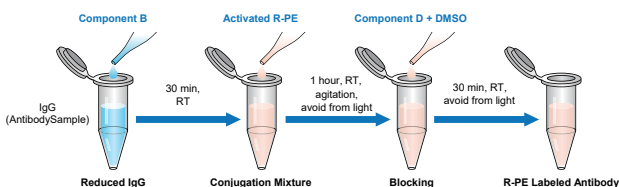

R-PE Labeled Anti-CD45 Antibody Test

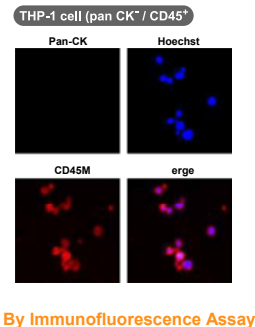
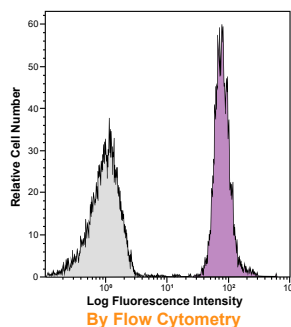

Order Details

Cat. No.	Name	Labeling Amount of Antibody	Recommended Amount of Antibody		Fixed Volume of Antibody
			Minimum (0.5 µg/mL)	Maximum (1 µg/mL)	
RPE01-0010	R-PE Labeling Kit	10 µg	5 µg	10 µg (optimal)	10 µL
RPE01-0100	R-PE Labeling Kit	100 µg	50 µg	100 µg (optimal)	100 µL

R-PE (R-Phycoerythrin)

Product Overview

Simply® R-PE is an intensely bright phycobiliprotein isolated from newly identified red algae species exclusive to coastal region of Taiwan. It exhibits extremely bright redorange fluorescence with high quantum yields. With its broad range of excitation wavelengths, it can be easily excited by laser lines from 488 nm to 561 nm (blue, green, and yellow laser lines), with absorbance peaks at 499, 541, and 565 nm and a fluorescence emission peak at 581 nm.

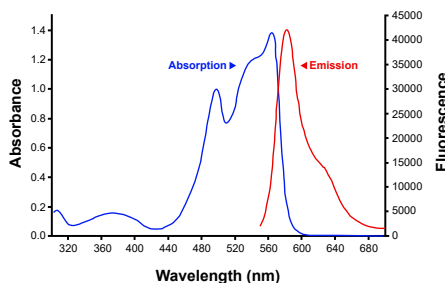

Stain index
158

Excitation max
499-565

Laser Line
488-561

Emission max
581

R-PE Spectral Characteristics Comparisons

Brand	Absorption Peaks (nm)	Emission max. (nm)	Extinction Coefficient(ε) x 10 ⁶ M ⁻¹ cm ⁻¹	Quantum Yied (QY)	Brightness (ε x QY) x 10 ⁶ M ⁻¹ cm ⁻¹
Simply	499,541,565	581	1.96	0.88	1.72
A Brand	498,539,565	578	1.96	0.82	1.67
B Brand	566	575	1.96	0.84	1.64

Features

- Brightness — Greater sensitivity and brighter than other conventional organic fluorophores
- Stability — Remains stable at variations in pH and temperature
- Quality — Meets International Purity Standard of R-PE by A566/A280→5.0, A566/A498←1.5, and A620/A566←0.01
- Compatibility — Compatible with fluorescence-based detection i.e. Flow Cytometry, Microarray, and Immunofluorescence Assay (IFA).

Order Details

Cat. No.	Name	R-PE Amount
RPE02-1000	R-PE (R-Phycoerythrin)	1 mg
RPE02-5000	R-PE (R-Phycoerythrin)	5 mg
RPE03-1000	SMCC-Activated R-PE	1 mg
RPE03-5000	SMCC-Activated R-PE	5 mg

CELL CULTURE

Transfection Reagents

Product Name	Cat. No.	Size	Page
Ultra293™ Transfection Reagent	MB506-1000 / SM506-1000	1 ml	72
Ultra293™ Transfection Reagent	MB506-0100 / SM506-0100	100 µl	72
UltraTRAX™ Transfection Reagent	MB508-1000 / SM508-1000	1 ml	72
UltraTRAX™ Transfection Reagent	MB508-0100 / SM508-0100	100 µl	72
Ultrafect-MEM	CC804-0100	100 ml	72
Ultrafect-MEM	CC804-0500	500 ml	72

Serum Reduced Formulation

Product Name	Cat. No.	Size	Page
ITS-M	CC002-1000	1 ml	73
SR Buffer	CC005-0080	80 ml	73
SR Supplement	CC006-0100	100 ml	73
SR DMEM, high glucose	CC813-0500	500 ml	74
SR RPMI 1640 Medium	CC814-0500	500 ml	74
SR DMEM/F-12 (1:1)	CC815-0500	500 ml	74

Specialty Media

Product Name	Cat. No.	Size	Page
mscGO™ XF	CC816-0100 / CC816-0500	100 ml / 500 ml	75
OneMEDIUM	CC817-0500	500 ml	76
KeraGo SFM Medium	CC818-0500	500 ml	77
CD-Freezer™ Medium	CC520-0100	100 ml	77
StemGO™ S-Replace	CC532-0050	50 ml	77
HybriGO™ SF Medium	CC801-0500	500 ml	78
NeuroGO™ Medium	CC802-0500	500 ml	78
InsectGO™ SF AOF SF9/SF21 Medium	CC811-0500	500 ml	78

Basal Media

Product Name	Cat. No.	Size	Page
DMEM, High Glucose	CC103-0500	500 mL	79
DMEM, High Glucose	CC105-0500	500 mL	79
DMEM, High Glucose	CC106-0500	500 mL	79
DMEM, High Glucose	CC107-0500	500 mL	79
DMEM, Low Glucose	CC108-0500	500 mL	79
DMEM Powder, High Glucose	CC126-1010	10 L X 1	79
RPMI 1640	CC109-0500	500 mL	79
RPMI 1640	CC110-0500	500 mL	79
RPMI 1640	CC111-0500	500 mL	79
RPMI 1640	CC112-0500	500 mL	79
RPMI 1640	CC142-0500	500 mL	79
RPMI 1640 Powder	CC128-1010	10 L X 1	79
DMEM/F-12	CC113-0500	500 mL	79
DMEM/F-12	CC115-0500	500 mL	79
MEM	CC116-0500	500 mL	80
MEM Alpha	CC117-0500	500 mL	80
MEM Powder	CC137-1010	10 L X 1	80
Ham's F-12K (Kaighn's Modification)	CC118-0500	500 mL	80
Ham's F-12	CC119-0500	500 mL	80

CELL CULTURE

Basal Media

Product Name	Cat. No.	Size	Page
Medium 199	CC121-0500	500 mL	80
Medium 199 Powder	CC141-1010	10 L X 1	80
McCoy's 5A	CC120-0500	500 mL	81
Leibovitz's L-15	CC122-0500	500 mL	81
IMDM	CC123-0500	500 mL	81

Balanced Salt

Product Name	Cat. No.	Size	Page
Dulbecco's PBS	CC702-0500	500 mL	81
Dulbecco's PBS, 10X	CC703-0500	500 mL	81
Dulbecco's PBS, 10X	CC704-0500	500 mL	81
Dulbecco's PBS Powder	CC701-1010	10 L X 1	81
HBSS	CC705-0500	500 mL	82
HBSS	CC706-0500	500 mL	82
HBSS, 10X	CC707-0500	500 mL	82
PBS (10X), pH 7.4	CC708-0500	500 mL	82
PBS, pH 7.4	CC711-0500	500 mL	82
10X PBST	CC709-0500	500 mL	82
10X TBST	CC710-0500	500 mL	82

Antibiotics

Product Name	Cat. No.	Size	Page
Antibiotic-Antimycotic, 100X	CC501-0100	100 mL	83
Penicillin-Streptomycin, 100X	CC502-0100	100 mL	83
Amphotericin B	CC505-0100	100 mL	83
Hygromycin B, 50 mg/mL	CC523-0010	10 mL	83
Gentamicin Solution, 50 mg/mL	CC527-0010	10 mL	83

Cell Dissociation Reagents

Product Name	Cat. No.	Size	Page
0.5% Trypsin-EDTA, 10X	CC507-0100	100 mL	84
0.25% Trypsin-EDTA, 1X	CC508-0100	100 mL	84
0.05% Trypsin-EDTA, 1X	CC509-0100	100 mL	84
0.25% Trypsin, 1X	CC510-0100	100 mL	84
2.5% Trypsin, 10X	CC511-0100	100 mL	84
TrypRC Clear, 1X	CC512-0100	100 mL	84

Supplements

Product Name	Cat. No.	Size	Page
L-Glutamine, 200 mM	CC515-0100	100 mL	85
GlutaGOTM Supplement, 100X	CC516-0100	100 mL	85
Non-Essential Amino Acids, 100X	CC517-0100	100 mL	85
Sodium Pyruvate, 100X	CC518-0100	100 mL	85
HEPES, 1M	CC519-0100	100 mL	85
HT Supplement, 100X	CC521-0100	50 mL	85
HAT Supplement, 50X	CC522-0100	100 mL	85
B 27 SF Supplement, 50X	CC528-0010	10 mL	86

CELL CULTURE

Supplements

Product Name	Cat. No.	Size	Page
N2 SF Supplement, 100X	CC529-0005	5 mL	86
7.5% Sodium Bicarbonate Solution	CC530-0100	100 mL	86

Water

Product Name	Cat. No.	Size	Page
Distilled Water	CC531-0500	500 ml	86

Human Recombinant Proteins

Product Name	Cat. No.	Size
IL-1 alpha, Human	SR101-0005	5 µg
	SR101-0020	20 µg
	SR101-0100	100 µg
IL-1 beta, Human	SR102-0005	5 µg
	SR102-0020	20 µg
	SR102-0100	100 µg
IL-1RA, Human	SR103-0005	5 µg
	SR103-0020	20 µg
	SR103-0100	100 µg
IL-2, Human	SR104-0005	5 µg
	SR104-0020	20 µg
	SR104-0100	100 µg
IL-3, Human	SR105-0005	5 µg
	SR105-0020	20 µg
	SR105-0100	100 µg
IL-4, Human	SR106-0005	5 µg
	SR106-0020	20 µg
	SR106-0100	100 µg
IL-5, Human	SR107-0005	5 µg
	SR107-0020	20 µg
	SR107-0100	100 µg
IL-6, Human	SR108-0005	5 µg
	SR108-0020	20 µg
	SR108-0100	100 µg
IL-7, Human	SR109-0005	5 µg
	SR109-0020	20 µg
	SR109-0100	100 µg
IL-8 (72 a.a.), Human	SR110-0005	5 µg
	SR110-0020	20 µg
	SR110-0100	100 µg
IL-9, Human	SR111-0005	5 µg
	SR111-0020	20 µg
	SR111-0100	100 µg
IL-10, Human	SR112-0005	5 µg
	SR112-0020	20 µg
	SR112-0100	100 µg
IL-11, Human	SR113-0005	5 µg
	SR113-0020	20 µg
	SR113-0100	100 µg
IL-12 p35, Human	SR114-0005	5 µg
	SR114-0020	20 µg
	SR114-0100	100 µg
IL-12 p40, Human	SR115-0005	5 µg
	SR115-0020	20 µg
	SR115-0100	100 µg

Product Name	Cat. No.	Size
IL-13, Human	SR116-0005	5 µg
	SR116-0020	20 µg
	SR116-0100	100 µg
IL-15, Human	SR117-0005	5 µg
	SR117-0020	20 µg
	SR117-0100	100 µg
IL-16 (129 a.a.), Human	SR118-0005	5 µg
	SR118-0020	20 µg
	SR118-0100	100 µg
IL-17A, Human	SR119-0005	5 µg
	SR119-0020	20 µg
	SR119-0100	100 µg
IL-17B, Human	SR120-0005	5 µg
	SR120-0020	20 µg
	SR120-0100	100 µg
IL-17D, Human	SR121-0005	5 µg
	SR121-0020	20 µg
	SR121-0100	100 µg
IL-17F, Human	SR122-0005	5 µg
	SR122-0020	20 µg
	SR122-0100	100 µg
IL-18, Human	SR123-0005	5 µg
	SR123-0020	20 µg
	SR123-0100	100 µg
IL-19, Human	SR124-0005	5 µg
	SR124-0020	20 µg
	SR124-0100	100 µg
IL-20, Human	SR125-0005	5 µg
	SR125-0020	20 µg
	SR125-0100	100 µg
IL-21, Human	SR126-0005	5 µg
	SR126-0020	20 µg
	SR126-0100	100 µg
IL-22, Human	SR127-0005	5 µg
	SR127-0020	20 µg
	SR127-0100	100 µg
IL-23 p19, Human	SR128-0005	5 µg
	SR128-0020	20 µg
	SR128-0100	100 µg
IL-24, Human	SR129-0005	5 µg
	SR129-0020	20 µg
	SR129-0100	100 µg
IL-25, Human	SR130-0005	5 µg
	SR130-0020	20 µg
	SR130-0100	100 µg

CELL CULTURE

Human Recombinant Proteins

Product Name	Cat. No.	Size
IL-26, Human	SR131-0005	5 µg
	SR131-0020	20 µg
	SR131-0100	100 µg
IL-27 EB13, Human	SR132-0005	5 µg
	SR132-0020	20 µg
	SR132-0100	100 µg
IL-28A, Human	SR133-0005	5 µg
	SR133-0020	20 µg
	SR133-0100	100 µg
IL-28B, Human	SR134-0005	5 µg
	SR134-0020	20 µg
	SR134-0100	100 µg
IL-29, Human	SR135-0005	5 µg
	SR135-0020	20 µg
	SR135-0100	100 µg
IL-30, Human	SR136-0005	5 µg
	SR136-0020	20 µg
	SR136-0100	100 µg
IL-31, Human	SR137-0005	5 µg
	SR137-0020	20 µg
	SR137-0100	100 µg
IL-32 alpha, Human	SR138-0005	5 µg
	SR138-0020	20 µg
	SR138-0100	100 µg
IL-33, Human	SR139-0005	5 µg
	SR139-0020	20 µg
	SR139-0100	100 µg
IL-34, Human	SR140-0005	5 µg
	SR140-0020	20 µg
	SR140-0100	100 µg
IL-36 alpha, Human	SR141-0005	5 µg
	SR141-0020	20 µg
	SR141-0100	100 µg
IL-36 beta, Human	SR142-0005	5 µg
	SR142-0020	20 µg
	SR142-0100	100 µg
IL-36 gamma, Human	SR143-0005	5 µg
	SR143-0020	20 µg
	SR143-0100	100 µg
IL-36RA, Human	SR144-0005	5 µg
	SR144-0020	20 µg
	SR144-0100	100 µg
IL-37, Human	SR145-0005	5 µg
	SR145-0020	20 µg
	SR145-0100	100 µg
IL-38, Human	SR146-0005	5 µg
	SR146-0020	20 µg
	SR146-0100	100 µg
TNF alpha, Human	SR147-0005	5 µg
	SR147-0020	20 µg
	SR147-0100	100 µg
TNF beta, Human	SR148-0005	5 µg
	SR148-0020	20 µg
	SR148-0100	100 µg
APRIL, Human	SR149-0005	5 µg
	SR149-0020	20 µg
	SR149-0100	100 µg

Product Name	Cat. No.	Size
AITRL, Human	SR150-0005	5 µg
	SR150-0020	20 µg
	SR150-0100	100 µg
BAFF, Human	SR151-0005	5 µg
	SR151-0020	20 µg
	SR151-0100	100 µg
CD27L, Human	SR152-0005	5 µg
	SR152-0020	20 µg
	SR152-0100	100 µg
CD30L, Human	SR153-0005	5 µg
	SR153-0020	20 µg
	SR153-0100	100 µg
CD40L, Human	SR154-0005	5 µg
	SR154-0020	20 µg
	SR154-0100	100 µg
FasL, Human	SR155-0005	5 µg
	SR155-0020	20 µg
	SR155-0100	100 µg
LIGHT, Human	SR156-0005	5 µg
	SR156-0020	20 µg
	SR156-0100	100 µg
RANKL, Human	SR157-0005	5 µg
	SR157-0020	20 µg
	SR157-0100	100 µg
TRAIL, Human	SR158-0005	5 µg
	SR158-0020	20 µg
	SR158-0100	100 µg
TL1A, Human	SR159-0005	5 µg
	SR159-0020	20 µg
	SR159-0100	100 µg
TWEAK, Human	SR160-0005	5 µg
	SR160-0020	20 µg
	SR160-0100	100 µg
BMP-2, Human	SR161-0005	5 µg
	SR161-0020	20 µg
	SR161-0100	100 µg
BMP-3, Human	SR162-0005	5 µg
	SR162-0020	20 µg
	SR162-0100	100 µg
BMP-4, Human	SR163-0005	5 µg
	SR163-0020	20 µg
	SR163-0100	100 µg
BMP-5, Human	SR164-0005	5 µg
	SR164-0020	20 µg
	SR164-0100	100 µg
BMP-6, Human	SR165-0005	5 µg
	SR165-0020	20 µg
	SR165-0100	100 µg
BMP-7, Human	SR166-0005	5 µg
	SR166-0020	20 µg
	SR166-0100	100 µg
BMP-8a, Human	SR167-0005	5 µg
	SR167-0020	20 µg
	SR167-0100	100 µg
BMP-8b, Human	SR168-0005	5 µg
	SR168-0020	20 µg
	SR168-0100	100 µg

CELL CULTURE

Human Recombinant Proteins

Product Name	Cat. No.	Size
BMP-9, Human	SR169-0005	5 µg
	SR169-0020	20 µg
	SR169-0100	100 µg
BMP-10, Human	SR170-0005	5 µg
	SR170-0020	20 µg
	SR170-0100	100 µg
BMP-11, Human	SR171-0005	5 µg
	SR171-0020	20 µg
	SR171-0100	100 µg
BMP-12, Human	SR172-0005	5 µg
	SR172-0020	20 µg
	SR172-0100	100 µg
BMP-13, Human	SR173-0005	5 µg
	SR173-0020	20 µg
	SR173-0100	100 µg
BMP-14, Human	SR174-0005	5 µg
	SR174-0020	20 µg
	SR174-0100	100 µg
BMP-15, Human	SR175-0005	5 µg
	SR175-0020	20 µg
	SR175-0100	100 µg
BMP-16, Human	SR176-0005	5 µg
	SR176-0020	20 µg
	SR176-0100	100 µg
IFN alpha 1a, Human	SR177-0005	5 µg
	SR177-0020	20 µg
	SR177-0100	100 µg
IFN beta 1a, Human	SR178-0005	5 µg
	SR178-0020	20 µg
	SR178-0100	100 µg
IFN gamma, Human	SR179-0005	5 µg
	SR179-0020	20 µg
	SR179-0100	100 µg
IFN omega, Human	SR180-0005	5 µg
	SR180-0020	20 µg
	SR180-0100	100 µg
HMGB1, Human	SR181-0005	5 µg
	SR181-0020	20 µg
	SR181-0100	100 µg
HMGB2, Human	SR182-0005	5 µg
	SR182-0020	20 µg
	SR182-0100	100 µg
4-1BBL, Human	SR183-0005	5 µg
	SR183-0020	20 µg
	SR183-0100	100 µg
Flt-3 Ligand, Human	SR184-0005	5 µg
	SR184-0020	20 µg
	SR184-0100	100 µg
LIF, Human	SR185-0005	5 µg
	SR185-0020	20 µg
	SR185-0100	100 µg
TGF alpha, Human	SR186-0005	5 µg
	SR186-0020	20 µg
	SR186-0100	100 µg
TGF beta 1, Human	SR187-0005	5 µg
	SR187-0020	20 µg
	SR187-0100	100 µg

Product Name	Cat. No.	Size
TGF beta 2, Human	SR188-0005	5 µg
	SR188-0020	20 µg
	SR188-0100	100 µg
TGF beta 3, Human	SR189-0005	5 µg
	SR189-0020	20 µg
	SR189-0100	100 µg
FGF-1, Human	SR190-0005	5 µg
	SR190-0020	20 µg
	SR190-0100	100 µg
FGF-2 (154 a.a.), Human	SR191-0005	5 µg
	SR191-0020	20 µg
	SR191-0100	100 µg
FGF-3, Human	SR192-0005	5 µg
	SR192-0020	20 µg
	SR192-0100	100 µg
FGF-4, Human	SR193-0005	5 µg
	SR193-0020	20 µg
	SR193-0100	100 µg
FGF-5, Human	SR194-0005	5 µg
	SR194-0020	20 µg
	SR194-0100	100 µg
FGF-6, Human	SR195-0005	5 µg
	SR195-0020	20 µg
	SR195-0100	100 µg
FGF-8a, Human	SR196-0005	5 µg
	SR196-0020	20 µg
	SR196-0100	100 µg
FGF-8b, Human	SR197-0005	5 µg
	SR197-0020	20 µg
	SR197-0100	100 µg
FGF-9, Human	SR198-0005	5 µg
	SR198-0020	20 µg
	SR198-0100	100 µg
FGF-10, Human	SR199-0005	5 µg
	SR199-0020	20 µg
	SR199-0100	100 µg
FGF-11 isoform 1, Human	SR200-0005	5 µg
	SR200-0020	20 µg
	SR200-0100	100 µg
FGF-11 isoform 2, Human	SR201-0005	5 µg
	SR201-0020	20 µg
	SR201-0100	100 µg
FGF-12, Human	SR202-0005	5 µg
	SR202-0020	20 µg
	SR202-0100	100 µg
FGF-13, Human	SR203-0005	5 µg
	SR203-0020	20 µg
	SR203-0100	100 µg
FGF-14, Human	SR204-0005	5 µg
	SR204-0020	20 µg
	SR204-0100	100 µg
FGF-16, Human	SR205-0005	5 µg
	SR205-0020	20 µg
	SR205-0100	100 µg
FGF-17, Human	SR206-0005	5 µg
	SR206-0020	20 µg
	SR206-0100	100 µg

CELL CULTURE

Human Recombinant Proteins

Product Name	Cat. No.	Size
FGF-18, Human	SR207-0005	5 µg
	SR207-0020	20 µg
	SR207-0100	100 µg
FGF-19, Human	SR208-0005	5 µg
	SR208-0020	20 µg
	SR208-0100	100 µg
FGF-20, Human	SR209-0005	5 µg
	SR209-0020	20 µg
	SR209-0100	100 µg
FGF-21, Human	SR210-0005	5 µg
	SR210-0020	20 µg
	SR210-0100	100 µg
FGF-22, Human	SR211-0005	5 µg
	SR211-0020	20 µg
	SR211-0100	100 µg
FGF-23, Human	SR212-0005	5 µg
	SR212-0020	20 µg
	SR212-0100	100 µg
IGF-I, Human	SR213-0005	5 µg
	SR213-0020	20 µg
	SR213-0100	100 µg
IGF-II, Human	SR214-0005	5 µg
	SR214-0020	20 µg
	SR214-0100	100 µg
GM-CSF, Human	SR215-0005	5 µg
	SR215-0020	20 µg
	SR215-0100	100 µg
M-CSF, Human	SR216-0005	5 µg
	SR216-0020	20 µg
	SR216-0100	100 µg
G-CSF, Human	SR217-0005	5 µg
	SR217-0020	20 µg
	SR217-0100	100 µg
Activin A, Human	SR218-0005	5 µg
	SR218-0020	20 µg
	SR218-0100	100 µg
Activin B, Human	SR219-0005	5 µg
	SR219-0020	20 µg
	SR219-0100	100 µg
EGF, Human	SR220-0005	5 µg
	SR220-0020	20 µg
	SR220-0100	100 µg
MIF, Human	SR221-0005	5 µg
	SR221-0020	20 µg
	SR221-0100	100 µg
HDGF, Human	SR222-0005	5 µg
	SR222-0020	20 µg
	SR222-0100	100 µg
VEGF121, Human	SR223-0005	5 µg
	SR223-0020	20 µg
	SR223-0100	100 µg
VEGF165, Human	SR224-0005	5 µg
	SR224-0020	20 µg
	SR224-0100	100 µg
TPO, Human	SR225-0005	5 µg
	SR225-0020	20 µg
	SR225-0100	100 µg

Product Name	Cat. No.	Size
CXCL1, Human	SR226-0005	5 µg
	SR226-0020	20 µg
	SR226-0100	100 µg
CXCL2, Human	SR227-0005	5 µg
	SR227-0020	20 µg
	SR227-0100	100 µg
CXCL3, Human	SR228-0005	5 µg
	SR228-0020	20 µg
	SR228-0100	100 µg
CXCL4, Human	SR229-0005	5 µg
	SR229-0020	20 µg
	SR229-0100	100 µg
CXCL5, Human	SR230-0005	5 µg
	SR230-0020	20 µg
	SR230-0100	100 µg
CXCL6, Human	SR231-0005	5 µg
	SR231-0020	20 µg
	SR231-0100	100 µg
CXCL7, Human	SR232-0005	5 µg
	SR232-0020	20 µg
	SR232-0100	100 µg
CXCL9, Human	SR233-0005	5 µg
	SR233-0020	20 µg
	SR233-0100	100 µg
CXCL10, Human	SR234-0005	5 µg
	SR234-0020	20 µg
	SR234-0100	100 µg
CXCL11, Human	SR235-0005	5 µg
	SR235-0020	20 µg
	SR235-0100	100 µg
CXCL12 (24-88), Human	SR236-0005	5 µg
	SR236-0020	20 µg
	SR236-0100	100 µg
CXCL13, Human	SR237-0005	5 µg
	SR237-0020	20 µg
	SR237-0100	100 µg
CCL2, Human	SR238-0005	5 µg
	SR238-0020	20 µg
	SR238-0100	100 µg
CCL3, Human	SR239-0005	5 µg
	SR239-0020	20 µg
	SR239-0100	100 µg
CCL4, Human	SR240-0005	5 µg
	SR240-0020	20 µg
	SR240-0100	100 µg
MMP7 (proenzyme), Human	SR241-0005	5 µg
	SR241-0020	20 µg
	SR241-0100	100 µg
MMP2 (active), Human	SR242-0005	5 µg
	SR242-0020	20 µg
	SR242-0100	100 µg
MMP7 (active), Human	SR243-0005	5 µg
	SR243-0020	20 µg
	SR243-0100	100 µg
PGA5, Human	SR244-0005	5 µg
	SR244-0020	20 µg
	SR244-0100	100 µg

CELL CULTURE

Human Recombinant Proteins

Product Name	Cat. No.	Size
CHI3L1, Human	SR245-0005	5 µg
	SR245-0020	20 µg
	SR245-0100	100 µg
OGG1, Human	SR246-0005	5 µg
	SR246-0020	20 µg
	SR246-0100	100 µg
BDNF, Human	SR247-0005	5 µg
	SR247-0020	20 µg
	SR247-0100	100 µg
CDNF, Human	SR248-0005	5 µg
	SR248-0020	20 µg
	SR248-0100	100 µg
CNTF, Human	SR249-0005	5 µg
	SR249-0020	20 µg
	SR249-0100	100 µg
GDNF, Human	SR250-0005	5 µg
	SR250-0020	20 µg
	SR250-0100	100 µg
Midkine, Human	SR251-0005	5 µg
	SR251-0020	20 µg
	SR251-0100	100 µg
Neurturin, Human	SR252-0005	5 µg
	SR252-0020	20 µg
	SR252-0100	100 µg
beta-NGF, Human	SR253-0005	5 µg
	SR253-0020	20 µg
	SR253-0100	100 µg
Pleiotrophin, Human	SR254-0005	5 µg
	SR254-0020	20 µg
	SR254-0100	100 µg
Galectin-1, Human	SR255-0005	5 µg
	SR255-0020	20 µg
	SR255-0100	100 µg
Galectin-2, Human	SR256-0005	5 µg
	SR256-0020	20 µg
	SR256-0100	100 µg
Galectin-3, Human	SR257-0005	5 µg
	SR257-0020	20 µg
	SR257-0100	100 µg
Galectin-4, Human	SR258-0005	5 µg
	SR258-0020	20 µg
	SR258-0100	100 µg
Galectin-7, Human	SR259-0005	5 µg
	SR259-0020	20 µg
	SR259-0100	100 µg
Galectin-8, Human	SR260-0005	5 µg
	SR260-0020	20 µg
	SR260-0100	100 µg
Galectin-9, Human	SR261-0005	5 µg
	SR261-0020	20 µg
	SR261-0100	100 µg
Galectin-10, Human	SR262-0005	5 µg
	SR262-0020	20 µg
	SR262-0100	100 µg
Galectin-12, Human	SR263-0005	5 µg
	SR263-0020	20 µg
	SR263-0100	100 µg

Product Name	Cat. No.	Size
Galectin-13, Human	SR264-0005	5 µg
	SR264-0020	20 µg
	SR264-0100	100 µg
Galectin-14, Human	SR265-0005	5 µg
	SR265-0020	20 µg
	SR265-0100	100 µg
Galectin-16, Human	SR266-0005	5 µg
	SR266-0020	20 µg
	SR266-0100	100 µg
Annexin V, Human	SR267-0005	5 µg
	SR267-0020	20 µg
	SR267-0100	100 µg
GIF, Human	SR268-0005	5 µg
	SR268-0020	20 µg
	SR268-0100	100 µg
CD326, Human	SR269-0005	5 µg
	SR269-0020	20 µg
	SR269-0100	100 µg
RAGE, Human	SR270-0005	5 µg
	SR270-0020	20 µg
	SR270-0100	100 µg
HMGB1, Human (mammalian cell expression)	SR271-0005	5 µg
	SR271-0020	20 µg
	SR271-0100	100 µg
HMGB1 C23AC45A, Human (mammalian cell expression)	SR272-0005	5 µg
	SR272-0020	20 µg
	SR272-0100	100 µg
HMGB1 C23AC45AC106A, Human (mammalian cell expression)	SR273-0005	5 µg
	SR273-0020	20 µg
	SR273-0100	100 µg
HMGB2, Human (mammalian cell expression)	SR274-0005	5 µg
	SR274-0020	20 µg
	SR274-0100	100 µg
Noggin, Human	SR275-0005	5 µg
	SR275-0020	20 µg
	SR275-0100	100 µg
SCF, Human	SR276-0005	5 µg
	SR276-0020	20 µg
	SR276-0100	100 µg
IL-12 p70, Human (mammalian cell expression)	SR277-0005	5 µg
	SR277-0020	20 µg
	SR277-0100	100 µg
Human IL-2 & IL-15 Fusion Protein, Tag Free	SR278-0005	5 µg
	SR278-0020	20 µg
	SR278-0100	100 µg

TRANSFECTION REAGENTS

Ultra293™ Transfection Reagent

Cat No.	Size
MB506-1000	1 ml
MB506-0100	100 µl
SM506-1000	1 ml
SM506-0100	100 µl

Description

The GeneDireX Ultra293™ is specifically optimized to provide exceptional transfection efficiency of plasmid DNA in HEK 293 and associated cell lineages. It provides all the attributes of the trusted transfection reagents: high transfection efficiency, low toxicity, simplicity of use and reproducibility. Ultra293™ is suitable for both transient and stable transfection and can be used for many applications. After Ultra293™ and plasmid mixed, the Ultra293™ / plasmid complexes protect DNA from degradation and facilitate efficient plasmid delivery into eukaryotic cells. It provides effectively, reproducibly, and affordable benefits for scientific research. The entire procedure can be completed in 35-40 minutes.

UltraTRAX™ Transfection Reagent

Cat No.	Size
MB508-1000	1 ml
MB508-0100	100 µl
SM508-1000	1 ml
SM508-0100	100 µl

Features

- Fast - only 30 minutes
- Excellent transfection efficiency in the presence or absence of serum

Description

The GeneDireX UltraTRAX™ Transfection Reagent is formulated to be a powerful transfection reagent that ensures effective and reproducible transfection with less cytotoxicity. After UltraTRAX™ and plasmid mixed, the UltraTRAX™ / plasmid complexes protect DNA from degradation and facilitate efficient plasmid delivery into eukaryotic cells. The entire procedure can be completed in 30 minutes.

Note

- For high efficiency and lower toxicity, transfect cells at 50~60% confluency is highly recommended.
- Maintain the same seeding conditions between experiments.
- Different cell types and number of passages might lead to different transfection efficiency, and we recommend using at least two different concentrations of transfection reagent as control in new transfect experiments to optimize experimental conditions.
- Endotoxin-contaminated DNA results in inefficient transfection and can cause high cellular toxicity.

Ultrafect-MEM

Cat No.	Size
CC804-0100	100 ml
CC804-0500	500 ml
[+] HEPES	[+] 2.4 g/L Sodium bicarbonate
[+] L-glutamine	

SERUM REDUCED FORMULATION

ITS-M, 500X (Insulin-Transferrin- Selenium Mixture, 500X)

Cat No.	Size
CC002-1000	1 ml

Feature

- Reduced the amount of Fetal Bovine Serum (FBS)

Description

ITS-M is a mixture of insulin, transferrin, and sodium selenite. It is a general cell supplement designed for use in basal media (e.g. MEM, DMEM, and RPMI-1640) and complex media (e.g. Ham's F-12 or DMEM/F12). It could be used to stimulate cell proliferation of a variety of cells under serum-reduced conditions and decrease the serum requirement of many cell types. Insulin is a hormone that promotes glucose and amino acid uptake by the cell. It is thought that the mitogenic effect of insulin is mediated by the insulin-like growth factor receptor, IGF-1 receptor. Transferrin is an iron transport protein that functions to transport iron into the cell. The protein also serves to detoxify the medium from oxygen radicals and peroxidase. Selenium is an enzyme cofactor that activates glutathione peroxidase, a player in the detoxification of oxygen radicals. When cells are cultured with medium contained ITS-M and low percent serum, proliferation is reported to be similar to those which medium were supplemented with 10 percent serum. Supplementation with ITS-M allows for a reduction in the serum requirement of the culture.

SR Buffer

Cat No.	Size
CC005-0080	80 ml

Features

- Economical alternative to FBS
- Performance comparable with FBS
- Low endotoxin and hemoglobin levels

Description

SR Buffer is a mixture of nutrients and designed to reduce serum in culture medium for cell proliferation. It is suitable for general basal media (e.g. MEM, DMEM, and RPMI-1640) and complex media (e.g. Ham's F-12 or DMEM/F12). The usage of SR Buffer is convenient and easy. We recommend mixing SR Buffer with fetal bovine serum (FBS) in ratio of 8 to 2. The mixture could be considered as serum replacement in culture medium. When cells are cultured within medium contained SR Buffer/FBS mixture, proliferation is reported to be similar to those which are in medium supplemented with serum. Application of SR Buffer could reduce serum in culture.

Application

- Supplement of cell culture.

Required Materials

- Cell culture medium
- FBS
- Antibiotic-Antimycotic/ Penicillin-Streptomycin

Quality Control

The quality of the SR Buffer is tested on a lot-to-lot basis to ensure consistent product quality.

SR Supplement

Cat No.	Size
CC006-1000	100 ml

Feature

- Replacement of FBS.
- Performance comparable with FBS
- Low endotoxin and hemoglobin levels

Description

SR Supplement is a mixture of fetal bovine serum (FBS) and serum replacement supplement in proportion for cell grown. SR Supplement could be considered as FBS replacement in cell culture. It is suitable for general basal media (e.g. MEM, DMEM, and RPMI-1640) and complex media (e.g. Ham's F-12 or DMEM/F12). When cells are cultured within medium contained SR Supplement, proliferation is reported to be similar to those which are in medium supplemented with FBS.

Application

- FBS replacement of cell culture.

Required Materials

- Basal medium
- Antibiotics, e.g., Antibiotic-Antimycotic/ Penicillin-Streptomycin

Quality Control

The quality of the SR Supplement is tested on a lot-to-lot basis to ensure consistent product quality.

SERUM REDUCED FORMULATION

SR DMEM, high glucose

Cat No.	Size	[+] 4.5 g/L D-Glucose	[+] MEM Non-Essential Amino Acids
CC813-0500	500 ml	[+] Phenol Red	[-] HEPES
		[+] 0.11 g/L Sodium Pyruvate	[-] L-Glutamine

Storage condition: 2-8°C, and should not be frozen, protect from light.
For research use only

Description

SR DMEM, high glucose, is widely used to culture mammalian cells with serum reduction. Compared to the classic DMEM high glucose, this formulation can reduce up to 50 ~ 90 % of serum usage without impacting cell growth rate or morphology. This medium allows for lower culture condition fluctuations and will sustain serum usage time. This product can be used to culture MDBK, HepG2, COS-7, A549, MDCK, WI-38, and Vero cells without domestication. The product is prepared using water-for-injection.

Storage and Stability

SR DMEM, high glucose should be stored at 2-8°C protected from light and should not be frozen. The product is stable until the expiration date shown on the label when stored accordingly.

Quality Control

The quality of the SR DMEM, high glucose is tested on a lot-to-lot basis to ensure consistent product quality.

SR RPMI 1640 Medium

Cat No.	Size
CC814-1000	500 ml

[+] Phenol Red	[-] HEPES
[+] 0.11 g/L Sodium Pyruvate	[-] L-Glutamine
[+] MEM Non-Essential Amino Acids	

SR DMEM/F-12 (1:1)

Cat No.	Size
CC815-0500	500 ml

Storage condition: 2-8°C, and should not be frozen, protect from light.
For research use only

Description

SR DMEM/F-12 (1:1) Medium is widely used to culture mammalian cells with serum reduction. Compared to the classic DMEM/F-12 (1:1), this formulation can reduce up to 50 ~ 90 % of serum usage without impacting cell growth rate and morphology. This medium allows for lower culture condition fluctuations and will sustain serum usage time. This product can be used to culture MRC-5, SP2, Vero, WI-38, and Jurkat cells without domestication. The product is prepared using water-for-injection. This product is for research use only not for clinical uses.

Storage and Stability

SR DMEM/F-12 (1:1) Medium should be stored at 2-8°C protected from light and should not be frozen. The product is stable until the expiration date shown on the label when stored accordingly.

Quality Control

The quality of the SR DMEM/F-12 (1:1) Medium is tested on a lot-to-lot basis to ensure consistent product quality.

[+] Phenol Red
[-] HEPES

100% pain-free transition Compatible with traditional medium
90% FBS reduction Less FBS consumption
1% FBS remain in medium Close to Serum Free!

Cell culture performance on APRE19 at day 17

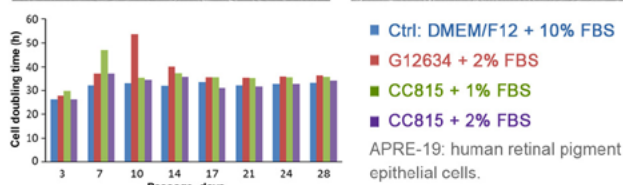
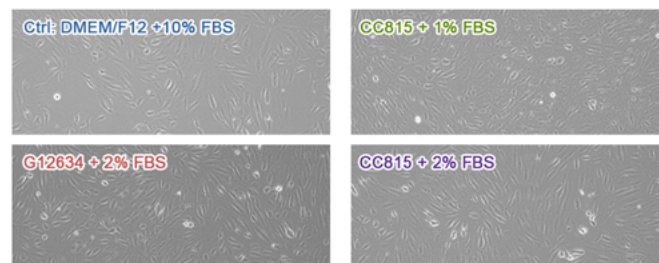

STR Verified

SR medium cultured cells were identified as the original source.

SPECIALTY MEDIA

mscGO™ XF

Cat No.	Size	
CC816-0100	100 ml	[+] Phenol Red [+] 3.9 g/L D-Glucose
CC816-0500	500 ml	[+] L-Glutamine

Storage

mscGO™ XF Medium store at 2-8°C protecting from light.

mscGO™ XF Supplement store at -20°C protecting from light.

Complete medium store at 2-8°C protecting from light.

Features

- No need to add any additional supplements.
- Suitable for the primary culture of MSC from bone marrow, adipose tissue and umbilical cord (UC).
- Enables competitive performance in human MSC growth compared to serum-supplemented (MEM-alpha + 20% FBS) as well as other commercial serum-free media.
- Using mscGO™ XF, human MSCs can be expanded beyond 5 passages while still maintaining their tri-lineage mesoderm differentiation potential (i.e., ability to differentiate into osteogenic, chondrogenic and adipogenic lineages)
- Using mscGO™ XF, no coating required.

Description

mscGO™ XF is a serum-free, xeno-free, and ready-to-use medium. The composition is optimized and recommended for ex vivo expansion of human mesenchymal stem cells (hMSCs) including bone marrow mesenchymal stem cell (BM-MSC), adipose-derived stem cell (ADSC) and umbilical cord-derived mesenchymal stem cell (UC-MSC). Human MSCs cultured within using complete mscGO™ XF Medium keep an excellent and stable expansion rate after several passages and maintain multi-lineage differentiation potential. A unique product is designed for general academic research use only. Do not use mscGO™ XF medium kit beyond the expiration date indicated on the products. The ingredients of mscGO™ XF are steady and all use GMP-compliant raw materials, so the product quality is quite stable and reliable.

Kit Contents

Contents	CC816-0100	CC816-0500
mscGO™ XF Medium	47.5 ml x 2	500 ml
mscGO™ XF Supplement	5 ml	25 ml

Application

- Cell culture.

Quality Control

The quality of the mscGO™ XF is tested on a lot-to-lot basis to ensure consistent product quality.

SPECIALTY MEDIA

OneMEDIUM

Cat No.	Size	[+] Phenol Red	[+] L-Glutamine
CC817-0500	500 ml	[+] 3.9 g/L D-Glucose	

- ✓ Sustain cell proliferation
- ✓ Genome stability/STR-PCR
- ✓ Cellular bioactivity

Description

OneMEDIUM is a new, novel and easy-to-use cell culture basal medium. It is an innovative application of cell culture methods. It simplifies experimental procedures, in the meanwhile, remains cell proliferation and maintains cellular activities. It is designed to replace the basic medium commonly used in cell culture.

Cell morphology using OneMEDIUM and their suggested medium.

Jurkat cell (human T lymphoblast) and ARPE-19 cell (human retinal pigmented epithelial cell) were expanded using OneMEDIUM supplemented with fetal bovine serum (FBS). Cell morphology culturing with OneMEDIUM is similar to their suggested medium (RPMI1640 and DMEMHG/F12).

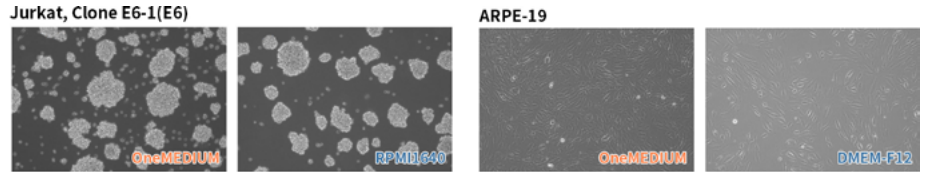

Dot blot analysis of anti-c-Myc expression in 9e10 cell conditioned medium.

9e10 cells culture using OneMEDIUM could sustain good antibody production even in reduced FBS condition.

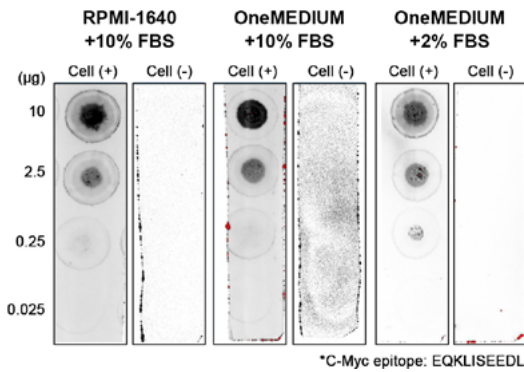

CD 45 expression on THP-1 cells.

Flow cytometry data histograms of different media has presented with a similar signal pattern of CD45 positive THP-1 cells cultured using OneMEDIUM.

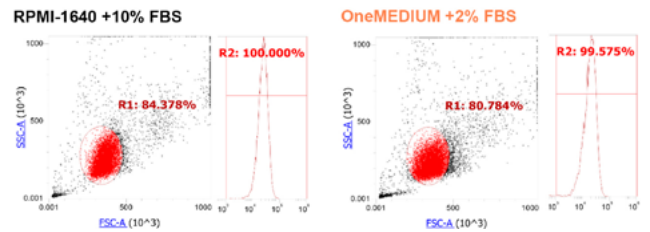

Cell morphology and CD90/CD105 expressions.

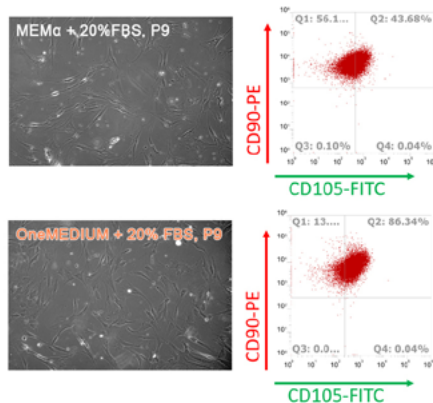

Cell differentiation tests on hBMMSC.

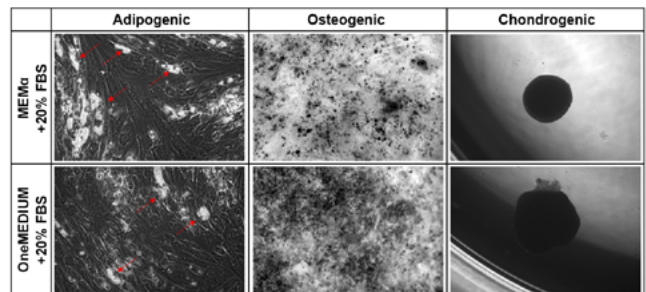

SPECIALTY MEDIA

KeraGo SFM Medium (Serum-free, Chemically-defined Culture Medium) for keratinocytes and epithelial cells

Cat No.	Size	Serum Free Medium Chemically-defined [+] L-Glutamine	[-] Supplement Supplied Separately Sterile-Filtered
CC818-0500	500 ml		

Feature

- To promote epithelial cells and keratinocytes proliferation *in vitro*.

Description

KeraGo SFM Medium is a serum-free, BPE (Bovine Pituitary Extract)-free, HPL (Human Platelet Lysate) -free, cholera toxin-free, chemically-defined culture medium for the growth and expansion of epithelial cells and keratinocytes without the use of feeder layers. KeraGo SFM Medium supports the primary culture of keratinocytes freshly isolated from tissues and the subsequent long-term culture. At the time of use, 500 mL of the basal medium of KeraGo is added with 0.5 mL of KeraGo Growth Supplement which contains recombinant human epidermal growth factor (rhEGF) and recombinant human insulin-like growth factor-1 (rhIGF-1). The calcium concentration in KeraGo SFM Medium is 60 μ M. The complete medium of KeraGo contains essential and non-essential amino acids, lipids, vitamins, organic compounds, and inorganic salts. The medium is HEPES and sodium bicarbonate buffered. KeraGo SFM Medium does not contain antibiotics or antimycotics.

Kit Contents

Contents	Size
KeraGo SFM Medium	500 ml
KeraGo Growth Supplement	0.5 ml

Storage and Stability

- KeraGo Basal Medium should be stored at 4°C protected from light and should not be frozen.
The product is stable until the expiration date shown on the label when stored accordingly.
- KeraGo Growth Supplement should be stored at -20°C or below and protected from light.
The product is stable until the expiration date shown on the label when stored accordingly.
- The complete medium (i.e. supplemented medium) of KeraGo should also be stored at 4°C in the dark without being frozen.
- Be sure that the freezer for storage does not undergo freeze-thaw cycles.

Application

- Primary cell isolation and routine culture of epithelial cells and keratinocytes.

Quality Control

- The quality of the KeraGo SFM Medium is tested on a lot-to-lot basis to ensure consistent product quality.

CD-Freezer™ Medium

Cat No.	Size	[-] Phenol red Sterile-Filtered
CC520-0100	100 ml	

Description

CD -Freezer™ Medium is a cryopreservation medium after adding DMSO and suitable for cell lines cultured with serum-free or serum-contained media. CD -Freezer™ Medium is chemically defined and animal origin-free medium to avoiding contamination from virus, fungus and mycoplasma.

StemGO™ S-Replace

Cat No.	Size
CC532-0050	50 ml

Description

StemGO™ S-Replace is a serum-free medium supplement that supports the growth of pluripotent stem cells (PSCs) cultured on fibroblast feeder cells. StemGO™ S-Replace is designed to replace fetal bovine serum (FBS) in existing protocols.

SPECIALTY MEDIA

HybriGO™ SF Medium

Cat No.	Size	Serum-Free	[+] Phenol red
CC801-0500	500 ml	[+] L-glutamine	Sterile-Filtered

Description

HybriGO™ SF Medium is a serum-free medium optimized for the growth of a variety of hybridomas and the production of monoclonal antibodies in primary cultures from both the peripheral nervous system (PNS) and the central nervous system (CNS).

NeuroGO™ Medium

Cat No.	Size	Serum-Free	[-] Glutamine	[-] Aspartic acid
CC802-0500	500 ml	[+] Phenol red	[-] Clutamic acid	Sterile-Filtered

Description

NeuroGO™ Medium is a basal medium for the special cell culture requirements of pre-natal and embryonic neuronal cells when used with Simply™ B 27 SF Supplement or N2 SF Supplement. NeuroGO™ Medium allows for long-time and short-term maintenance of homogeneous populations of neuronal cells without the need of an astrocyte feeder layer. NeuroGO™ Medium can be used to grow neuronal cells from hippocampus, cortex and other regions of the brain.

InsectGO™ SF AOF SF9/SF21 Medium

Cat No.	Size	[+] 10 g/L D-Glucose	[-] Phenol red
CC811-0500	500 ml	[+] L-glutamine	[+] Sodium bicarbonate

Description

InsectGO™ SF AOF SF9/SF21 is a serum-free, animal-free, and ready-to-use insect cell culture medium. The medium is mainly developed for Baculovirus Expression Vector System (BEVS) applications in both monolayer and suspension culture. InsectGO™ SF AOF SF9/SF21 has been optimized the contents of amino acids, carbohydrates, vitamins, lipids, and other biologically active materials to improve its performance in virus production and recombinant protein expression. InsectGO™ SF AOF SF9/SF21 is designed for Spodoptera frugiperda cells (Sf9/Sf21), and also support the cell growth for other *Trichoplusia ni* cell lines. The medium contains no phenol red.

Product parameter

Physical appearance: clear liquid

Endotoxin: ≤ 3 EU/mL

Osmotic pressure: 340-380 mOsm/kg H₂O

pH value: 6.0 - 6.4

Note: The presence of chromatic aberration in each batch of InsectGO™ SF AOF SF9/SF21 is normal and does not affect use. The main reason for the chromatic aberration is due to a batch-to-batch difference in the color of the yeast powder added to the medium.

Culture Conditions

Media: InsectGO™ SF AOF SF9/SF21 Medium

Cell lines: Sf9, Sf21, Ld, Tn-368 cells

Culture types: Adherent or suspension cells

Incubation conditions: 27-28°C, non-humidified and non-CO₂ atmosphere, minimize exposure of cultures to light.

In the following experimental protocol, the suspension culture was carried out using a 125 mL conical flask; the adherent culture vessels were all T75. For example, in the case of cell culture flasks, ensure proper gas exchange when adherent cells are cultured.

Medium preparation

InsectGO™ SF AOF SF9/SF21 is a complete, ready to use medium, no additional components are required for normal use.

BASAL MEDIA

DMEM (Dulbecco's Modified Eagle's Medium)

Description

DMEM (Dulbecco's Modified Eagle Medium) is a modification of Basal Medium Eagle (BME) that contains a four-fold higher concentration of amino acids and vitamins, as well as additional supplementary components. DMEM is well suited for supporting the growth of a broad spectrum of mammalian cell lines.

DMEM comparison list

Product Name	DMEM, High Glucose	DMEM, High Glucose	DMEM, High Glucose	DMEM, High Glucose	DMEM, Low Glucose	DMEM Powder, High Glucose
Cat no.	CC103-0500	CC105-0500	CC106-0500	CC107-0500	CC108-0500	CC126-1010
Size	500 ml	500 ml	500 ml	500 ml	500 ml	10 L X 1
High Glucose (4500 mg/L)	V	V	V	V		V
Low Glucose (1000 mg/L)					V	
With Sodium pyruvate (110 mg/L)	V			V	V	V
With L-glutamine	V	V		V	V	V
With HEPES (25 mM)						
With phenol red	V	V	V		V	V
Powder					V	V

RPMI 1640

Description

Roswell Park Memorial Institute (RPMI) 1640 Medium are enriched formulations with extensive applications for mammalian cells. RPMI 1640 Medium was developed to culture human leukemic cells in suspension and as a monolayer.

RPMI 1640 comparison list

Product Name	RPMI 1640	RPMI 1640	RPMI 1640	RPMI 1640	RPMI 1640	RPMI 1640 Powder
Cat no.	CC109-0500	CC110-0500	CC111-0500	CC112-0500	CC142-0500	CC128-1010
Size	500 ml	500 ml	500 ml	500 ml	500 ml	10 L X 1
With Glucose (2000 mg/L)	V	V	V	V	V	V
With L-glutamine		V	V	V	V	V
With HEPES (25 mM)				V		
With HEPES (10 mM)					V	
With phenol red	V	V		V	V	V
Powder						V

DMEM/F-12

Description

DMEM/F-12 (Dulbecco's Modified Eagle Medium/Nutrient Mixture F-12) is a 1:1 mixture of DMEM and Ham's F-12. DMEM/F-12 is widely used basal medium for supporting the growth of many different mammalian cells.

RPMI 1640 comparison list

Product Name	DMEM/F-12	DMEM/F-12
Cat no.	CC113-0500	CC115-0500
Size	500 ml	500 ml
With L-glutamine	V	V
With HEPES (25 mM)	V	
With phenol red	V	V

BASAL MEDIA

MEM

Description

Minimum Essential Media (MEM) are well suited for the growth of a broad spectrum of mammalian cells. MEM α (Minimum Essential Medium α) is widely used for suspension and adherent mammalian cell culture.

MEM comparison list

Product Name	MEM	MEM Alpha	MEM Powder
Cat no.	CC116-0500	CC117-0500	CC137-1010
Size	500 ml	500 ml	10 L X 1
With L-glutamine	V	V	V
With non-essential amino acids			V
With phenol red	V	V	V
Powder			V

Ham's F-12K (Kaighn's) Medium

Cat No.	Size	[+] L-glutamine	Sterile-Filtered
CC118-0500	500 ml		

Description

Ham's F-12K (Kaighn's Modification) Medium is a modification of Ham's F-12 Nutrient Mixture.

Ham's F-12 Nutrient Mix

Cat No.	Size	[+] L-glutamine	Sterile-Filtered
CC119-0500	500 ml		

Description

Ham's F-12 Nutrient Mixture (F-12) was formulated for serum-free, single-cell plating of Chinese Hamster Ovary (CHO) cells.

Medium 199

Cat No.	Size	[+] Earle's salts	[+] L-glutamine
CC121-0500	500 ml	Sterile-Filtered	

Description

Medium 199 was originally developed for nutritional studies on chick embryo fibroblasts. It is widely used in virology and vaccine production.

Medium 199 Powder

Cat No.	Size	[+] Earle's salts	[+] L-glutamine
CC141-1010	10 L X 1	[+] Sodium bicarbonate	

Description

Medium 199 was originally developed for nutritional studies on chick embryo fibroblasts. It is widely used in virology and vaccine production.

BASAL MEDIA

McCoy's 5A

Cat No.	Size	[+] L-glutamine	Sterile-Filtered
CC120-0500	500 ml		

Description

McCoy's 5A Medium is supporting the propagation of many types of primary cells, established cell lines, and explants from biopsy tissues.

Leibovitz's L-15

Cat No.	Size	[+] L-glutamine	Sterile-Filtered
CC122-0500	500 ml		

Description

Leibovitz's L-15 Media are suited for supporting cell growth in non-CO₂ equilibration environment. These formulations were developed without a sodium bicarbonate buffer system.

IMDM

Cat No.	Size	[+] L-glutamine	[+] 25mM HEPES
CC123-0500	500 ml	[+] Sodium bicarbonate	[+] alpha-thioglycerol
		[+] 2-mercaptoethanol	Sterile-Filtered

Description

Iscove's Modified Dulbecco's Media (IMDM) are highly enriched synthetic media. IMDM is well suited for rapidly proliferating, high-density cell cultures.

BALANCED SALT

Dulbecco's PBS

Cat No.	Size		
CC702-0500	500 ml		
		[-] Calcium	[-] Magnesium
		[-] Phenol red	Sterile-Filtered

Dulbecco's PBS, 10X

Cat No.	Size		
CC703-0500	500 ml		
		[+] Calcium	[+] Magnesium
		[-] Phenol red	Sterile-Filtered

Dulbecco's PBS, 10X

Cat No.	Size		
CC704-0500	500 ml		
		[-] Calcium	[-] Magnesium
		[-] Phenol red	

Dulbecco's PBS Powder

Cat No.	Size		
CC701-1010	10 L X 1		
		[-] Calcium	[-] Magnesium

BALANCED SALT

HBSS

Cat No.	Size
CC705-0500	500 ml
[+] Glucose	[-] Calcium
[-] Magnesium	[-] Phenol red
Sterile-Filtered	

HBSS

Cat No.	Size
CC706-0500	500 ml
[+] Glucose	[+] Phenol red
[-] Calcium	[-] Magnesium
Sterile-Filtered	

HBSS, 10X

Cat No.	Size
CC707-0500	500 ml
[+] Glucose	[-] Phenol red
[-] Calcium	[-] Magnesium
[-] Sodium bicarbonate	Sterile-Filtered

PBS (10X), pH 7.4

Cat No.	Size
CC708-0500	500 ml
[-] Calcium	[-] Magnesium
[-] Phenol red	

PBS, pH7.4

Cat No.	Size
CC711-0500	500 ml
[-] Calcium	[-] Magnesium
[-] Phenol Red	

10X PBST

Cat No.	Size
CC709-0500	500 ml

Description

10X PBST is a concentrated solution of Phosphate Buffered Saline with Tween 20. It contains 80mM Na₂HPO₄, 1.5M NaCl, 20mM KH₂PO₄, 30mM KCl, 0.5% Tween 20, and has a pH of 7.4.

This product is commonly used as a wash solution for Western blot membranes and microtiter plate wells in ELISA assays. It is an optimal formulation of pH stabilizers, salts, and detergents that is designed to effectively remove excess material from membranes and microtiter plate wells without disrupting the antigen/antibody binding reaction. By maintaining the proper buffering environment, unbound components can be washed away without suppressing antigen-antibody binding interactions, thereby reducing nonspecific background and increasing the specific signal.

10X TBST

Cat No.	Size
CC710-0500	500 ml

100mM Tris.HCl, 150mM NaCl, 0.5% Tween-20 at pH7.5

ANTIBIOTICS

Antibiotic-Antimycotic, 100X

Cat No.	Size	[+] 10,000 units/mL penicillin [+] 25ug/mL Amphotericin B	[+] 10,000 ug/mL streptomycin Sterile-Filtered
CC501-0100	100 ml		

Description

Contains 10,000 units/mL of penicillin, 10,000µg/mL streptomycin, and 25µg/mL amphotericin B in a 0.85% saline solution. Effective against bacteria, fungi, and yeasts.

Penicillin-Streptomycin (10,000 U/ml)

Cat No.	Size	[+] 10,000 units/mL penicillin Sterile-Filtered	[+] 10,000 ug/mL streptomycin
CC502-0100	100 ml		

Description

Contains 10,000 units/mL of penicillin and 10,000 µg/mL streptomycin in 0.85% saline. Effective against gram-positive and gram-negative bacteria. Suitable for use in cell culture.

Amphotericin B

Cat No.	Size	[+] 5,000 units/mL penicillin Sterile-Filtered	[+] 5,000 µg/mL streptomycin
CC505-0100	100 ml		

Description

Contains 250µg/mL amphotericin B and 250µg/mL sodium deoxycholate in distilled water. Effective against fungi and yeasts.

Hygromycin B, 50 mg/ml

Cat No.	Size	Sterile-Filtered
CC523-0010	10 ml	

Description

Formula: $C_{20}H_{37}N_3O_{13}$

Formula Weight: 527.5

Hygromycin B is a water-soluble antibiotic purified from the bacterium *Streptomyces hydroscopicus*.

Hygromycin B is used as a bacterial selection antibiotic in the concentration range of 200–500 µg/mL.

This product is supplied as a 50 mg/mL solution.

Gentamicin Solution, 50 mg/ml

Cat No.	Size	Application: Prevention of Cell Culture Contamination Sterile-Filtered
CC527-0010	10 ml	

Description

Gentamicin sulfate is a water-soluble antibiotic originally purified from the fungus *Micromonospora purpurea*. Gentamicin is effective against a wide variety of gram-positive and gram-negative bacteria, and is used to prevent the contamination of cell cultures by bacteria. The recommended working concentration ranges from 0.5 to 50 µg/mL.

CELL DISSOCIATION REAGENTS

0.5% Trypsin-EDTA, 10X

Cat No.	Size	[-] Phenol red
CC507-0100	100 ml	Sterile-Filtered

Description

Contains 5.0 g/L trypsin (from Porcine pancreas), 2.0 g/L EDTA-4Na and 8.5 g/L NaCl. 0.5% Trypsin-EDTA is concentrated form. It can be diluted to 1X using a balanced salt solution without calcium and magnesium.

0.25% Trypsin-EDTA, 1X

Cat No.	Size	[+] Phenol red
CC508-0100	100 ml	Sterile-Filtered

Description

Contains 2.5 g/L trypsin (from Porcine pancreas), 0.38 g/L EDTA-4Na and phenol red in HBSS without calcium and magnesium.

0.05% Trypsin-EDTA, 1X

Cat No.	Size	[+] Phenol red
CC509-0100	100 ml	Sterile-Filtered

Description

Contains 0.5 g/L trypsin (from Porcine pancreas), 0.2 g/L EDTA-4Na and phenol red in HBSS without calcium and magnesium.

0.25% Trypsin, 1X

Cat No.	Size	[+] Phenol red
CC510-0100	100 ml	Sterile-Filtered

Description

Contains 2.5 g/L trypsin (from Porcine pancreas) and phenol red in HBSS without calcium and magnesium.

2.5% Trypsin, 10X

Cat No.	Size	[-] Phenol red
CC511-0100	100 ml	Sterile-Filtered

Description

Contains 25 g/L trypsin (from Porcine pancreas) and 8.5 g/L NaCl but no phenol red.

TrypRC Clear, 1X

Cat No.	Size	[-] Phenol red
CC512-0100	100 ml	Sterile-Filtered

Description

TrypRC™ is a recombinant enzyme alternative to animal trypsin for the dissociation of adherent cell lines from plasticware. TrypRC™ is animal origin-free and thus ideal for both serum and serum-free cultures.

SUPPLEMENTS

L-Glutamine, 200 mM

Cat No.	Size	
CC515-0100	100 ml	Sterile-Filtered

Description

Contains 29.2 mg/ml L-glutamine in 0.85% sodium chloride solution.

GlutaGO™ Supplement, 100X

Cat No.	Size	
CC516-0100	100 ml	200 mM dipeptide L-alanyl-L-glutamine Sterile-Filtered

Description

GlutaGO™ Supplement is 200 mM dipeptide L-alanyl-L-glutamine in 0.85% sodium chloride. GlutaGO™ Supplement is highly soluble, heat-stable, and does not spontaneously break down to form ammonia for longer lasting cultures. GlutaGO™ Supplement can be used as a direct substitute for L-glutamine at equimolar concentrations in both adherent and suspension mammalian cell cultures.

Non-Essential Amino Acids, 100X

Cat No.	Size	
CC517-0100	100 ml	Sterile-Filtered

Description

The non-essential amino acids in this solution are 100X the concentration in the MEM medium.

Sodium Pyruvate, 100X

Cat No.	Size	
CC518-0100	100 ml	11 g/L Sodium pyruvate Sterile-Filtered

Description

Contains 11 g/L sodium pyruvate in purified water.

HEPES, 1M

Cat No.	Size	
CC519-0100	100 ml	Buffer Solution Sterile-Filtered

Description

Contains 238.3 g/L HEPES in purified water. pH range is 7.2 - 7.5.

HT Supplement, 100X

Cat No.	Size	
CC521-0050	50 ml	Protect from light

HAT Supplement, 50X

Cat No.	Size	
CC522-0100	100 ml	

SUPPLEMENTS

B 27 SF Supplement, 50X

Cat No.	Size	
CC528-0010	10 ml	Sterile-Filtered

N2 SF Supplement, 100X

Cat No.	Size	
CC529-0005	5 ml	Sterile-Filtered

7.5% Sodium Bicarbonate Solution

Cat No.	Size	
CC530-0100	100 ml	Sterile-Filtered

Description

Contains 75 mg/ml sodium bicarbonate in purified water.

WATER

Distilled Water

Cat No.	Size	
CC531-0500	500 ml	Purification: Membrane-Filtered Sterile-Filtered



PLASTIC CONSUMABLES

Centrifuge Tube

Product Name	Cat. No.	Size	Page
1.5 ml Microcentrifuge Tube	PC101-5000	5000 Tubes/Case	89
2 ml Microcentrifuge Tube	PC102-5000	5000 Tubes/Case	89
15 ml Centrifuge Tube	PC115-0500	500 Tubes/Case	90
15 ml Conical Centrifuge Tube	PC116-0500	500 Tubes/Case	90
50 ml Centrifuge Tube	PC150-0500	500 Tubes/Case	91
50 ml Conical Centrifuge Tube	PC151-0500	500 Tubes/Case	91

PCR Tube

Product Name	Cat. No.	Size	Page
0.2 ml PCR Tube	PC121-1000	1000 Tubes/Case	92

Cryogenic Vial

Product Name	Cat. No.	Size	Page
Cryogenic Vial, 2.0 ml, External	PC130-1000	1000 Tubes/Case	92
Cryogenic Vial, 2.0 ml, Internal (w/ o-ring)	PC131-1000	1000 Tubes/Case	93

Cell Strainers

Product Name	Cat. No.	Size	Page
Cell Strainers, 100 μ m	PC171-0050	50 PCS/Box	94
Cell Strainers, 70 μ m	PC172-0050	50 PCS/Box	94
Cell Strainers, 40 μ m	PC173-0050	50 PCS/Box	94

Cell Culture Dish

Product Name	Cat. No.	Size	Page
35 mm Cell Culture Dish	PC201-0500	500 Dishes/Case	95
60 mm Cell Culture Dish	PC202-0500	500 Dishes/Case	95
60 mm Cell Culture Dish	PC203-0600	600 Dishes/Case	95
100 mm Cell Culture Dish	PC205-0300	300 Dishes/Case	96
100 mm Cell Culture Dish	PC206-0300	300 Dishes/Case	96
150 mm Cell Culture Dish	PC207-0100	100 Dishes/Case	96

Glass Bottom Culture Dish

Product Name	Cat. No.	Size	Page
30 mm Glass Bottom Culture Dish with 15 mm Glass Diameter	PC208-0010	10 PCS/Bag	97
30 mm Glass Bottom Culture Dish with 20 mm Glass Diameter	PC209-0010	10 PCS/Bag	98

Petri Dishes

Product Name	Cat. No.	Size	Page
90 mm Petri Dishes, Sterile	PC800-0500	500 Dishes/Case	99

PLASTIC CONSUMABLES

Cell Culture Flask

Product Name	Cat. No.	Size	Page
25 cm ² Cell Culture Flask, Vent Cap	PC272-0200	200 PCS/Case	100
75 cm ² Cell Culture Flask, Vent Cap	PC275-0100	100 PCS/Case	100
175 cm ² Cell Culture Flask, Vent Cap	PC277-0040	40 PCS/Case	101
225 cm ² Cell Culture Flask, Vent Cap	PC279-0025	25 PCS/Case	101

ELISA Plate

Product Name	Cat. No.	Size	Page
96 well ELISA Plate	PC301-0200	200 Plates/Case	102

Cell Culture Plate

Product Name	Cat. No.	Size	Page
6 Well Cell Culture Plate	PC306-0050	50 Plates/Case	103
12 Well Cell Culture Plate	PC312-0050	50 Plates/Case	104
24 Well Cell Culture Plate	PC324-0050	50 Plates/Case	105
48 Well Cell Culture Plate	PC348-0050	50 Plates/Case	106
96 Well Cell Culture Plate	PC396-0100	100 Plates/Case	107

Serological Pipet

Product Name	Cat. No.	Size	Page
2 ml Serological Pipet	PC502-0500	500 Pipets/Case	108
5 ml Serological Pipet	PC505-0200	200 Pipets/Case	108
10 ml Serological Pipet	PC510-0200	200 Pipets/Case	109
25 ml Serological Pipet	PC525-0150	150 Pipets/Case	109
50 ml Serological Pipet	PC550-0100	100 Pipets/Case	110

Filter

Product Name	Cat. No.	Size	Page
PES Syringe Filter 33 mm, 22 um	PC601-0050	50 PCS/Case	111
PVDF Syringe Filter 33 mm, 22 um	PC602-0050	50 PCS/Case	111
Filter Cup 500 ml	PC651-0024	24 PCS/Case	111
Filter Cup 500 ml RTYPE	PC652-0024	24 PCS/Case	112

Cell Scrape

Product Name	Cat. No.	Size	Page
Cell Scrape 220 mm, 13 mm	PC722-0100	100 PCS/Case	112
Cell Scrape 280 mm, 20 mm	PC728-0100	100 PCS/Case	112

CENTRIFUGE TUBE

1.5 ml Microcentrifuge Tube

Cat No.	Size
PC101-5000	5000 Tubes/Case

Features

- Using imported PP materials, resistant to chemical corrosion and low temperature, compliant to USP Class 6 standard
- Ultra high centrifugal stability, centrifugal tolerance up to 30,000xg
- Withstand sterilization under high temperature and pressure 121°C/15psi
- Tube cap can be opened or closed with one hand, easy to operate
- Available in sterile or unsterile options
- None of DNA RNA enzyme or endotoxin

Description

Microcentrifuge tubes are made of transparent high polymer materials polypropylene (PP), used with microcentrifuge and widely used in molecular biology, clinical chemistry and biochemical research.

Sterile

No

Materials

Tube: PP

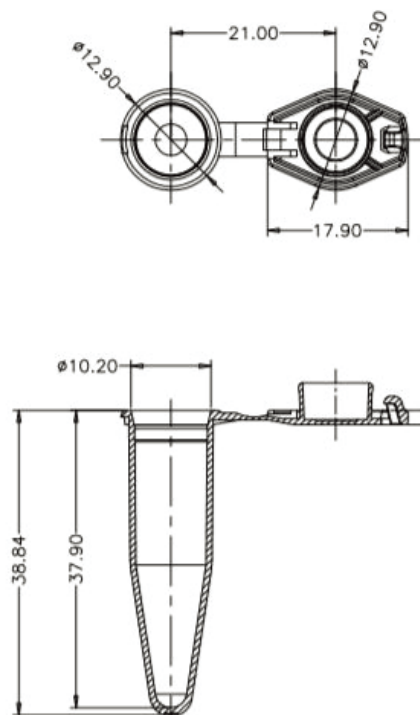

2 ml Microcentrifuge Tube

Cat No.	Size
PC102-5000	5000 Tubes/Case

Features

- Using high quality PP materials, resistant to chemical corrosion and low temperature, compliant to USP Class 6 standard
- Ultra high centrifugal stability, centrifugal tolerance up to 30,000xg
- Withstand sterilization under high temperature and pressure 121°C/15psi
- Tube cap can be opened or closed with one hand, easy to operate
- Available in sterile or unsterile options
- None of DNA RNA enzyme or endotoxin

Description

Microcentrifuge tubes are made of transparent high polymer materials polypropylene (PP), used with microcentrifuge and widely used in molecular biology, clinical chemistry and biochemical research.

Sterile

No

Materials

Tube: PP

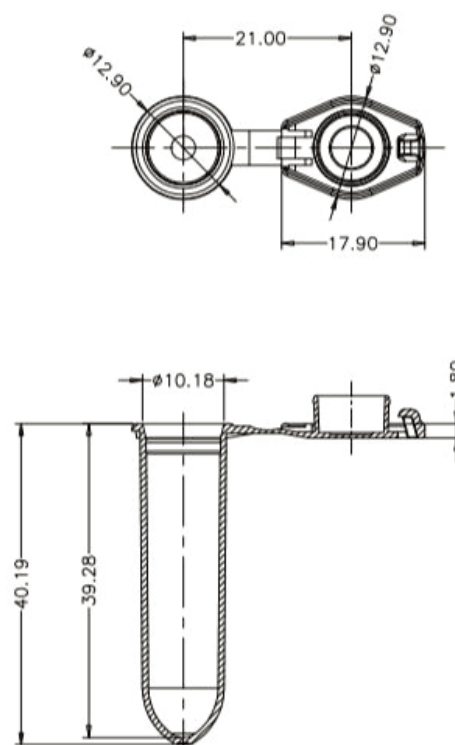

CENTRIFUGE TUBE

15 ml Centrifuge Tube

Cat No.	Size
PC115-0500	25 Tubes/Bag, 500 Tubes/Case

Features

- Tubes are made from high grade gamma resistance polypropylene
- Easy-to-read black graduations in $\pm 2\%$ increments
- Contains a large, white frosted writing area
- Autoclavable at 121°C and freezable to -80°C
- Max rotate speed up to 12,000xg for conical bottom tubes
- DNase/RNase free
- Non-pyrogenic
- Leak-proof
- Sterilized by gamma irradiation SAL10⁻⁶ (ISO11137)
- Shelf Life: 3 years after month of production
- Manufactured in a Class 100,000 cleanroom environment
- Manufactured under ISO13485 and ISO9001 quality management system

Description: 15 ml, Flat cap, Conical Bottom, Sterilized

Sterile: Yes

Purpose: Popular in samples centrifuging or storage in many research area

Materials

Tube: PP (Polypropylene) Color: Clear
 Cap: PE (Polyethylene) Color: Blue

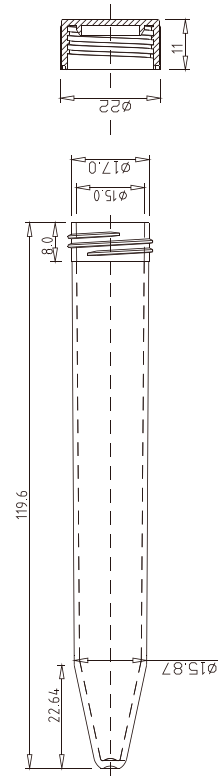

15 ml Conical Centrifuge Tube

Cat No.	Size
PC116-0500	50 Tubes/Bag, 500 Tubes/Case

Features

- USP VI Materials
- Meet the requirements of analytical level
- High strength non-toxic materials
- Printed clear graduations with marking area
- PP for the tube and HDPE for the cap
- One-hand operation design
- Sterilized by E-Beam
- DNase, RNase and pyrogen free

Description

Temperature Range: Approx. -80 to +121°C

Shelf Life: 3 years after date of production

Sterile: Yes

Product Range

Volume(ml): 15 ml

Color: Transparency

Packaging: Bagged

Max.RCF[xg]: 12,000

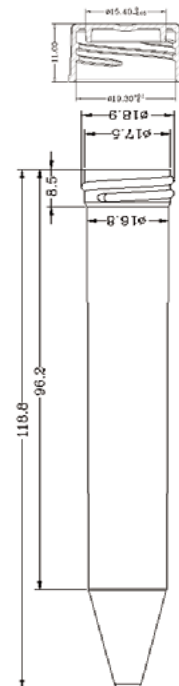

CENTRIFUGE TUBE

50 ml Centrifuge Tube

Cat No.	Size
PC150-0500	25 Tubes/Bag, 500 Tubes/Case

Features

- Tubes are made from high grade gamma resistance polypropylene
- Easy-to-read black graduations in $\pm 2\%$ increments
- Contains a large, white frosted writing area
- Autoclavable at 121°C and freezable to -80°C
- Max rotate speed up to 12,000xg for conical bottom tubes, while 6,000xg for self-standing tubes
- DNase/RNase free
- Non-pyrogenic
- Leak-proof
- Sterilized by gamma irradiation SAL10⁻⁶ (ISO11137)
- Shelf Life: 3 years after month of production
- Manufactured in a Class 100,000 cleanroom environment
- Manufactured under ISO13485 and ISO9001 quality management system

Description

50 ml, Flat cap,
Conical Bottom, Sterilized

Sterile

Yes

Purpose

Popular in samples centrifuging
or storage in many research
area

Materials

Tube: PP (Polypropylene)
Color: Clear
Cap: PE (Polyethylene)
Color: Blue

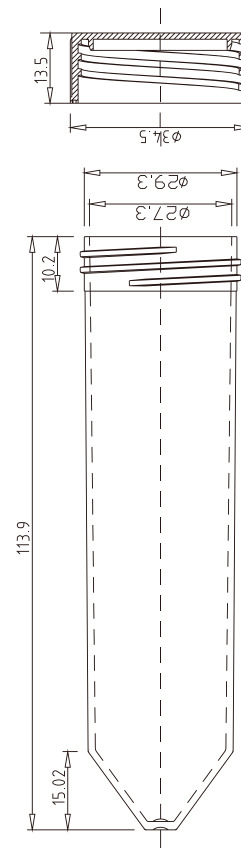

50 ml Conical Centrifuge Tube

Cat No.	Size
PC151-0500	25 Tubes/Bag, 500 Tubes/Case

Features

- USP VI Materials
- Meet the requirements of analytical level
- High strength non-toxic materials
- Printed clear graduations with marking area
- PP for the tube and HDPE for the cap
- One-hand operation design
- Sterilized by E-Beam
- DNase, RNase and pyrogen free

Description

Temperature Range: Approx. -80 to +121°C
Shelf Life: 3 years after date of production
Sterile: Yes

Product Range

Volume(ml): 50 ml
Color: transparency
Packaging: Bagged
Max.RCF[xg]: 12,000

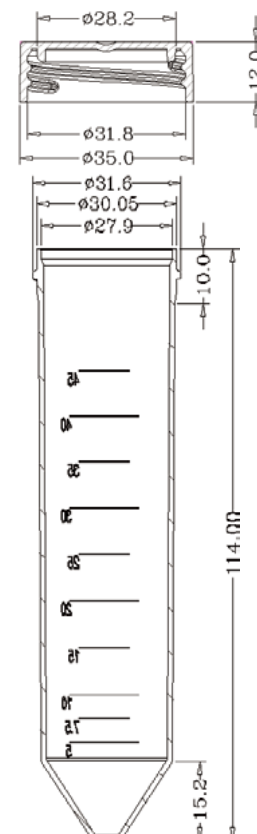

PCR TUBE & CRYOGENIC VIAL

0.2 ml PCR tube

Cat No.	Size
PC121-1000	1000 Tubes/Case

Features

- Compatible with most thermal cyclers PCR machine
- Extra-thin walls provide the optimal thermal transfer and shorter cycle times
- Easy open leak proof cap makes the loss of reaction less than 5%
- Free of Dnase and Rnase, human DNA and PCR inhibitor
- Autoclavable

Made from USP grade VI polypropylene

Cap Type: Flat

Color: Transparent

Volume (ml): 0.2 ml

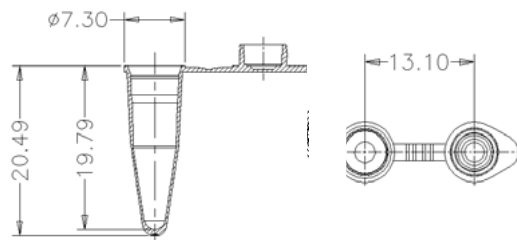

Cryogenic Vials, 2.0 ml, External

Cat No.	Size
PC130-1000	1000 Tubes/Case

Applications

- Cryogenic storage
- Cell centrifugation
- Reaction tube
- Centrifugation of precipitates

Tube features

- Materials: Strong, medical grade polypropylene Autoclavable, can be repeatedly frozen and thawed.
- Strong mechanical and chemical resistance.
- Transparent wall permits easy viewing of tube contents.
- Stable from -196°C to 121°C (gas phase liquid nitrogen).
- Designed & tested for long-term liquid nitrogen storage.
- Sterile, RNase & DNase Endotoxin Free, Foreign DNA Free.
- No O-ring, reduces risk of sample contamination.
- Manufactured under ISO 9001:2015 quality management system

Warning

Do not use cryogenic vials in liquid phase of liquid nitrogen.
Ideal for cryogenic sample storage in gas phase of liquid nitrogen.

Tube design

- Starfoot design design; easy single handed opening and closing.
- Clearly visible with either clear or cloudy samples.
- With black graduations and white writing area.

Cap design

- O-ring free design for super seal.
- 2 ml vials with white caps.

Sterility

Yes



CRYOGENIC VIAL

Cryogenic Vials, 2.0 ml, Internal

Cat No.	Size
PC131-1000	1000 Tubes/Case

Applications

- Sample storage
- Cell centrifugation
- Reaction tube
- Centrifugation of precipitates

Tube features

- Materials: Strong, medical grade polypropylene.
- Chemically resistant to alcohols and mild organic solvents.
- Transparent wall permits easy viewing of tube contents.
- Working temperature: stable from -196°C to 121°C (Autoclavable, freeze proof and boil proof).
- Sterile, RNase & DNase Free, Endotoxin Free.
- Manufactured under ISO 9001:2015 quality management system

Warning

Do not use cryogenic vials in liquid phase of liquid nitrogen.
Ideal for cryogenic sample storage in gas phase of liquid nitrogen.

Tube design

- Self standing design.
- Available in 2.0 ml volumes.
- Clearly visible with either clear or turbid samples.
- With graduations and writing area.
- With interior screw thread type

Cap design

- Clear Screw cap with silicone o-ring screwed on the tubes.
- 2 ml Vials with red caps.

Sterility

Yes



CELL STRAINERS

Cell Strainers (100 µm, 70 µm, 40 µm)

Name	Cat No.	Size
Cell Strainers, 100 µm	PC171-0200	200 PCS/Case
Cell Strainers, 70 µm	PC172-0200	200 PCS/Case
Cell Strainers, 40 µm	PC173-0200	200 PCS/Case

Features

- Available in 3 mesh pore sizes: 100 µm, 70 µm and 40 µm
- 3 different colors: blue, white and yellow, for easy identification
- Made of a strong nylon mesh with evenly spaced mesh pores
- Improved uniformity of single cell suspensions
- The extended lip on the strainer enables aseptic handling with forceps
- Design to fit perfectly into a Simply® 50 ml centrifuge tube
- Non-cytotoxic
- DNase/RNase free and Non-pyrogenic
- Sterilized by irradiation SAL10⁻⁶ (ISO11137)
- Shelf Life: 3 years after month of production
- Manufactured in a class 100,000 room environment
- Manufactured under ISO13485 and ISO9001 quality management system

Dimensions (Unit:mm)

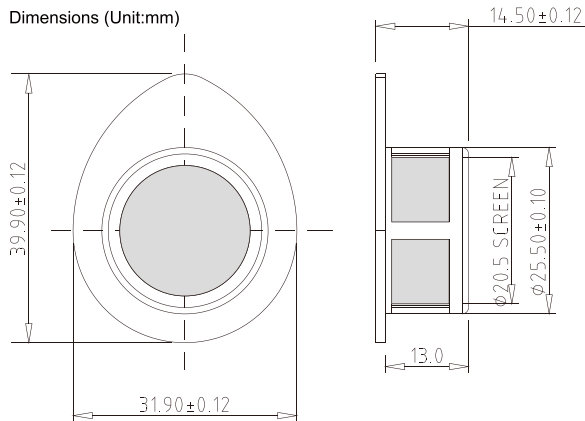

Description: Cell Strainers, Nylon mesh, Blister packed

Sterile: Yes

Purpose

Cell strainers are sterile, rapid, easy-to-use devices for isolating primary cells to consistently obtain a uniform single-cell suspension from tissues

Materials

Cat. No.	Color	Frame	Mesh
PC171-0200	Yellow	PP (Polypropylene)	Nylon
PC172-0200	White		
PC173-0200	Blue		



CELL CULTURE DISH

35 mm Cell Culture Dish

Cat No.	Size
PC201-0500	500 Dishes/Case

Features

- High clarity polystyrene
- Flat transparent surface for distortion-free observation
- Vacuum plasma TC treatment, excellent cell adherence
- Stackable for easy storage and handling
- Sterilized by E-Beam
- Non-pyrogenic

Description

Temperature Range: Approx. -86 to +64°C
 Shelf Life: 3 Years after date of production (ensure package is in good)
 Sterile: Yes

Spec		Cell Growth	Recommended
Type	Height (mm)	Area (cm ²)	Medium Volume (ml)
35	12	8.5	1.8-2.7

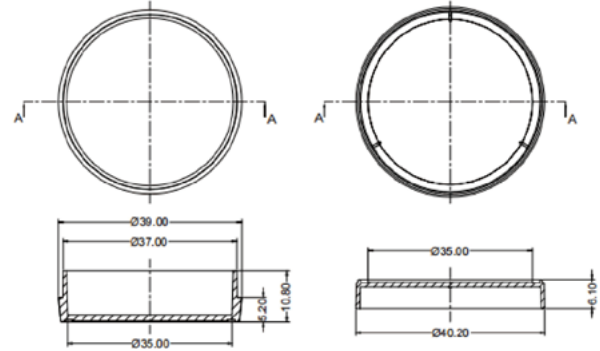

60 mm Cell Culture Dish

Cat No.	Size
PC202-0500	500 Dishes/Case

Features

- High clarity polystyrene
- Flat transparent surface for distortion-free observation
- Vacuum plasma TC treatment, excellent cell adherence
- Stackable for easy storage and handling
- Sterilized by E-Beam
- Non-pyrogenic

Description

Temperature Range: Approx. -86 to +64°C
 Shelf Life: 3 Years after date of production (ensure package is in good)
 Sterile: Yes

Spec		Cell Growth	Recommended
Type	Height (mm)	Area (cm ²)	Medium Volume (ml)
60	15	22.9	4.2-6.3

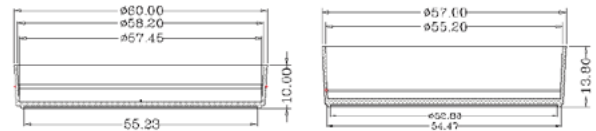

60 mm Cell Culture Dish (Gripping Ring)

Cat No.	Size
PC203-0600	600 Dishes/Case

Features

- Every inner bag is printed with a batch number for traceability
- Sterilized by gamma irradiation SAL10⁻⁶ (ISO11137)
- Non-pyrogenic
- Flat bottom uniform wall thickness ensures distortion-free bottom
- Lids with several little chimbs to shape vents are available for very effective gas exchange
- Bulk packed in zip-Lock bag
- Autoclavability: No
- Manufactured in a Class 100,000 cleanroom environment
- Manufactured under ISO13485 and ISO9001 quality management system

Description

Temperature Range: Approx. -20°C--+50°C
 Shelf Life: 3 years after month of production
 Sterile: Yes

Spec		Cell Growth	Recommended
Type	Height (mm)	Area (cm ²)	Medium Volume (ml)
60 (With Gripping Ring)	12	8.5	1.8-2.7

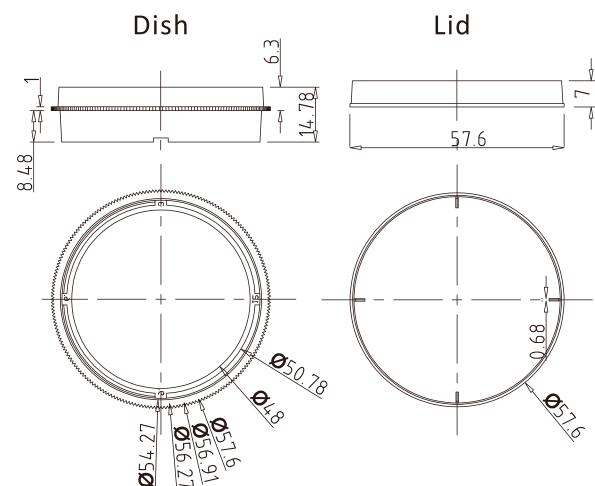

CELL CULTURE DISH

100 mm Cell Culture Dish

Cat No.	Size
PC205-0300	300 Dishes/Case

Features

- High clarity polystyrene
- Flat transparent surface for distortion-free observation
- Vacuum plasma TC treatment, excellent cell adherence
- Stackable for easy storage and handling
- Sterilized by E-Beam
- Non-pyrogenic

Description

Temperature Range: Approx. -86 to +64°C
 Shelf Life: 3 Years after date of production (ensure package is in good)
 Sterile: Yes

Spec		Cell Growth Area (cm ²)	Recommended Medium Volume (ml)
Type	Height (mm)		
100	20	57.6	11-16.5

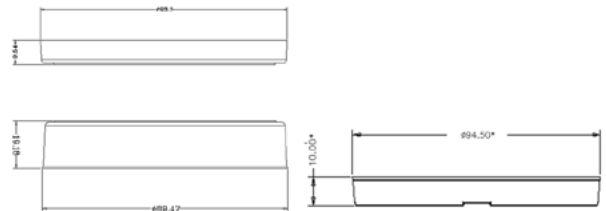

100 mm Cell Culture Dish (Gripping Ring)

Cat No.	Size
PC206-0300	300 Dishes/Case

Features

- High clarity polystyrene
- Flat transparent surface for distortion-free observation
- Vacuum plasma TC treatment, excellent cell adherence
- Stackable for easy storage and handling
- Sterilized by E-Beam
- Non-pyrogenic

Description

Temperature Range: Approx. -86 to +64°C
 Shelf Life: 3 Years after date of production (ensure package is in good)
 Sterile: Yes

Spec		Cell Growth Area (cm ²)	Recommended Medium Volume (ml)
Type	Height (mm)		
100 (With Gripping Ring)	20	59.3	11-16.5

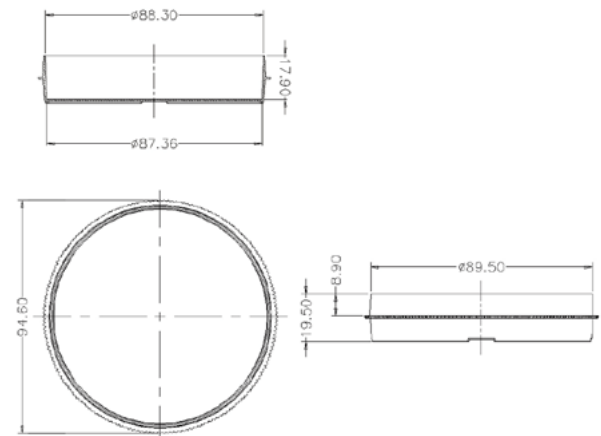

150 mm Cell Culture Dish

Cat No.	Size
PC207-0100	100 Dishes/Case

Features

- High clarity polystyrene
- Flat transparent surface for distortion-free observation
- Vacuum plasma TC treatment, excellent cell adherence
- Stackable for easy storage and handling
- Sterilized by E-Beam
- Non-pyrogenic

Description

Temperature Range: Approx. -86 to +64°C
 Shelf Life: 3 Years after date of production (ensure package is in good)
 Sterile: Yes

Spec		Cell Growth Area (cm ²)	Recommended Medium Volume (ml)
Type	Height (mm)		
150	25	150.1	30.4-45.6

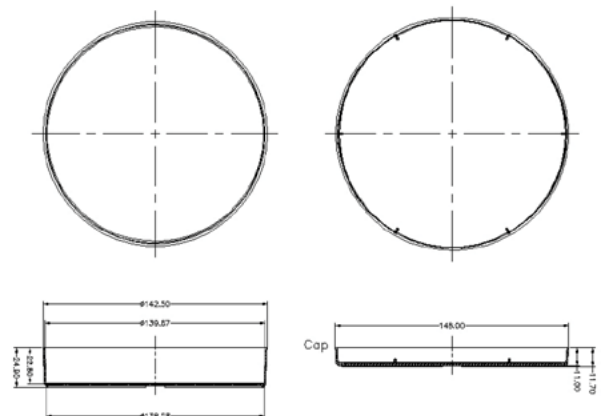

GLASS BOTTOM CULTURE DISH

30 mm Glass Bottom Culture Dish with 15 mm Glass Diameter

Cat No.	Size
PC208-0010	10/Bag

Features

- High clarity, 100% virgin polystyrene and high clarity glass as bottoms. Product Materials meets USP, Class VI.
- High quality cover glass of standard thickness 0.17 mm.
- Medical adhesive glue to guarantee non-cytotoxicity.
- With stand temperature range: Approx. -86°C to 64°C
- Can be used for live cell observation.
- Special bottom design for easy grip, Round cover glass insert for good appearance.

Product Application

Simply® glass bottom series are applied in confocal microscope, high resolution microscope, differential interference contrast microscope, polarized light microscope and phase contrast microscope for cell observation.

- Cell biology: STEM cell research, cell cycle regulation
- Protein chemistry: GFP (green fluorescent protein) identification
- Molecular biology: genetic mapping and complex genetic research
- Biological research based on Laser Confocal Microscopy
- Research based on dual / multi-photon confocal microscopy
- High-quality imaging system
- Infrared imaging

Product Materials

PS + Imported borosilicate glass (bottom)
Meets USP, Class VI standards. Yes

Product Specifications

Temperature range: stored at room temperature
Shelf life: 3 Years after date of production (ensure package is in good)

Sterilization

Yes.
Sterilized by E-beam, Sterility Assurance Level: SAL=10⁻⁶. The product has been irradiated and dosimetrically released based on ANSI/AAMI/ISO 11137

Pyrogens

Non-Pyrogenic

RNase/DNase

DNase/RNase free

BSE/TSE

These products are deemed animal free.

Performance Testing

Each manufacturing lot is sampled and tested in accordance with standard operating procedures.
Appearance inspection: qualified
Hydrophilic test: qualified
Cell culture test: qualified
Packaging inspection: qualified

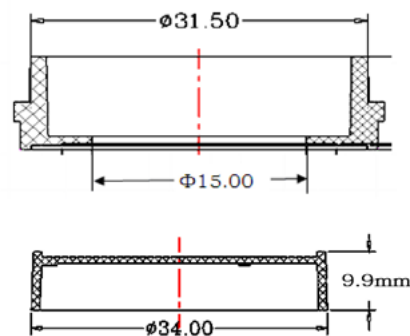

Product Description			Pack
Spec (mm)		Cultivation Area (cm ²)	
Type	Glass Diameter		
28.5	15	6.2	10

GLASS BOTTOM CULTURE DISH

30 mm Glass Bottom Culture Dish with 20 mm Glass Diameter

Cat No.	Size
PC209-0010	10/Bag

Features

- High clarity, 100% virgin polystyrene and high clarity glass as bottoms. Product Materials meets *USP, Class VI*.
- High quality cover glass of standard thickness 0.17 mm.
- Medical adhesive glue to guarantee non-cytotoxicity.
- With stand temperature range: Approx. -86°C to 64°C
- Can be used for live cell observation.
- Special bottom design for easy grip, Round cover glass insert for good appearance.

Product Application

Simply® glass bottom series are applied in confocal microscope, high resolution microscope, differential interference contrast microscope, polarized light microscope and phase contrast microscope for cell observation.

- Cell biology: STEM cell research, cell cycle regulation
- Protein chemistry: GFP (green fluorescent protein) identification
- Molecular biology: genetic mapping and complex genetic research
- Biological research based on Laser Confocal Microscopy
- Research based on dual / multi-photon confocal microscopy
- High-quality imaging system
- Infrared imaging

Product Materials

PS + Imported borosilicate glass (bottom)
Meets *USP, Class VI* standards. Yes

Product Specifications

Temperature range: stored at room temperature
Shelf life: 3 Years after date of production (ensure package is in good)

Sterilization

Yes.
Sterilized by E-beam, Sterility Assurance Level: SAL=10⁻⁶. The product has been irradiated and dosimetrically released based on ANSI/AAMI/ISO 11137

Pyrogens

Non-Pyrogenic

RNase/DNase

DNase/RNase free

BSE/TSE

These products are deemed animal free.

Performance Testing

Each manufacturing lot is sampled and tested in accordance with standard operating procedures.
Appearance inspection: qualified
Hydrophilic test: qualified
Cell culture test: qualified
Packaging inspection: qualified

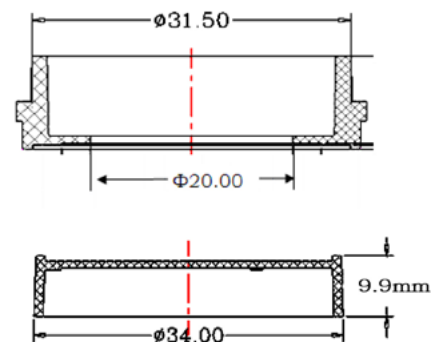

Product Description			Pack
Spec (mm)		Cultivation Area (cm ²)	
Type	Glass Diameter		
28.5	20	6.2	10

PETRI DISHES

90 mm Petri Dishes, Sterile

Cat No.	Size
PC800-0500	500 Dishes/Case

Features

- Temperature: -20°C~+50°C
- Non-pyrogenic
- Uniform wall thickness ensures distortion-free bottom
- Lids with several little chimbs to shape vents are available for very effective gas exchange
- Dish surface is smooth and free from striation to maximize usable area for growth
- DNase/RNase free
- Growth area: 55 cm²
- Autoclavability: No
- Every inner bag is printed with a batch number for traceability
- Shelf Life: 3 years after month of production
- Sterilized by gamma irradiation SAL=10⁻⁶
- Manufactured in a Class 100,000 clean room environment
- Manufactured under 15013485 and ISO9001 quality management system

Purpose

Petri dishes are right containers for bacterial culture, and also useful for sample separation, pre-treatment and storage

Materials

Dish: GPPS (General polystyrene)	Color: Clear
Lid: GPPS (General polystyrene)	Color: Clear

Dimensions (Unit: mm)

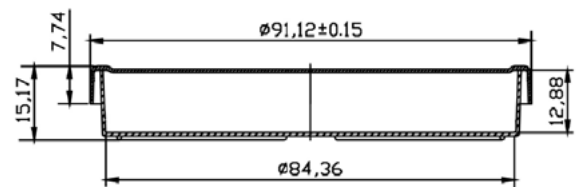

CELL CULTURE FLASK

25 cm² Cell Culture Flask

Cat No.	Size
PC272-0200	200 PCS/Case

Features

- Temperature Range: Approx. -86 to +64°C
- High clarity medical grade polystyrene material
- Sterilized by E-Beam SAL=10⁻⁶
- Non-pyrogenic, DNase/ RNase free, free, Non-Cytotoxicity
- Packaged in sterile, zip-sealable bags
- Cap style : vent caps
- Vent caps with 0.22 μm hydrophobic filters for gas exchange without contamination
- Fosted writing and clear graduation
- Shelf Life: 3 Years after date of production (ensure package is in good)
- Clear lot number for batch traceability
- Stackable

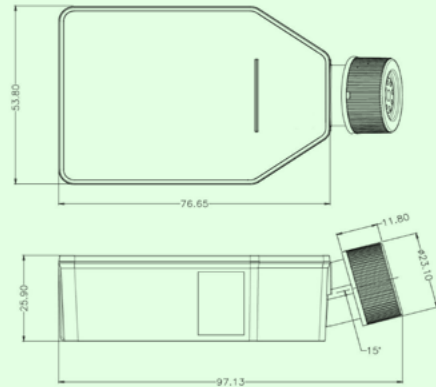

Simply cell culture flasks are an ideal solution for enhanced cell attachment and growth of a variety of primary cells and transformed cells in serum free or serum-containing cultures.

Description

Tissue Culture Treated Cell Culture Flasks, 50 ml

Sterile

Yes

Materials

Flask: PS (Polystyrene)

Cap: HDPE (Polyethylene)

Vent cap: 0.22 μm hydrophobic filters

Cat. No.	Cell Growth Area(cm ²)	Cap Style	Volume (ml)	Recommended Medium Volume(ml)
PC272-0200	25	Vent Cap	50	5-7.5

75 cm² Cell Culture Flask

Cat No.	Size
PC275-0100	100 PCS/Case

Features

- Temperature Range: Approx. -86 to +64°C
- High clarity medical grade polystyrene material
- Sterilized by E-Beam SAL=10⁻⁶
- Non-pyrogenic, DNase/ RNase free, free, Non-Cytotoxicity
- Packaged in sterile, zip-sealable bags
- Cap style : vent caps
- Vent caps with 0.22 μm hydrophobic filters for gas exchange without contamination
- Fosted writing and clear graduation
- Shelf Life: 3 Years after date of production (ensure package is in good)
- Clear lot number for batch traceability
- Stackable

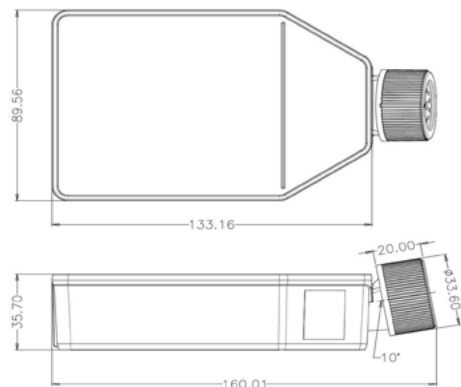

Simply cell culture flasks are an ideal solution for enhanced cell attachment and growth of a variety of primary cells and transformed cells in serum free or serum-containing cultures.

Description

Tissue Culture Treated Cell Culture Flasks, 250 ml

Sterile

Yes

Materials

Flask: PS (Polystyrene)

Cap: HDPE (Polyethylene)

Vent cap: 0.22 μm hydrophobic filters

Cat. No.	Cell Growth Area(cm ²)	Cap Style	Volume (ml)	Recommended Medium Volume(ml)
PC275-0100	75	Vent Cap	250	15-22.5

CELL CULTURE FLASK

175 cm² Cell Culture Flask

Cat No.	Size
PC277-0040	40 PCS/Case

Features

- Temperature Range: Approx. -86 to +64°C
- High clarity medical grade polystyrene material
- Sterilized by E-Beam SAL=10⁻⁶
- Non-pyrogenic, DNase/ RNase free, free, Non-Cytotoxicity
- Packaged in sterile, zip-sealable bags
- Cap style : vent caps
- Vent caps with 0.22 μm hydrophobic filters for gas exchange without contamination
- Fostered writing and clear graduation
- Shelf Life: 3 Years after date of production (ensure package is in good)
- Clear lot number for batch traceability
- Stackable

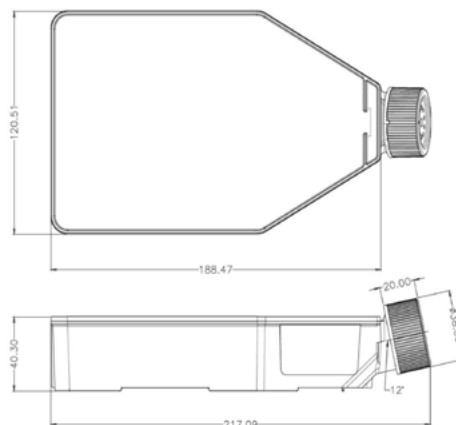

Simply cell culture flasks are an ideal solution for enhanced cell attachment and growth of a variety of primary cells and transformed cells in serum free or serum-containing cultures.

Description

Tissue Culture Treated Cell Culture Flasks, 750 ml

Sterile

Yes

Materials

Flask: PS (Polystyrene)

Cap: HDPE (Polyethylene)

Vent cap: 0.22 μm hydrophobic filters

Cat. No.	Cell Growth Area(cm ²)	Cap Style	Volume (ml)	Recommended Medium Volume(ml)
PC277-0040	175	Vent Cap	750	35-52.5

225 cm² Cell Culture Flask

Cat No.	Size
PC279-0025	25 PCS/Case

Features

- Temperature Range: Approx. -86 to +64°C
- High clarity medical grade polystyrene material
- Sterilized by E-Beam SAL=10⁻⁶
- Non-pyrogenic, DNase/ RNase free, free, Non-Cytotoxicity
- Packaged in sterile, zip-sealable bags
- Cap style : vent caps
- Vent caps with 0.22 μm hydrophobic filters for gas exchange without contamination
- Fostered writing and clear graduation
- Shelf Life: 3 Years after date of production (ensure package is in good)
- Clear lot number for batch traceability
- Stackable

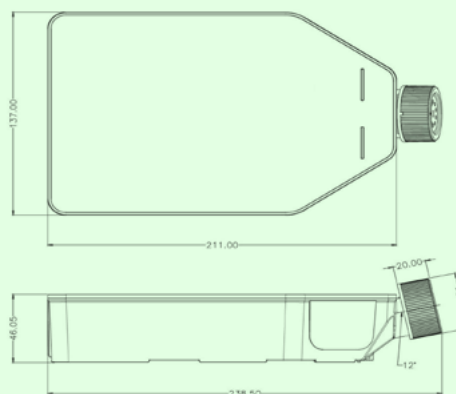

Simply cell culture flasks are an ideal solution for enhanced cell attachment and growth of a variety of primary cells and transformed cells in serum free or serum-containing cultures.

Description

Tissue Culture Treated Cell Culture Flasks, 950 ml

Sterile

Yes

Materials

Flask: PS (Polystyrene)

Cap: HDPE (Polyethylene)

Vent cap: 0.22 μm hydrophobic filters

Cat. No.	Cell Growth Area(cm ²)	Cap Style	Volume (ml)	Recommended Medium Volume(ml)
PC279-0025	225	Vent Cap	950	45-67.5

ELISA PLATE

96-Well ELISA Plate

Cat No.	Size
PC301-0200	200 Plates/Case

Features

- Available protein binding capability well surface
- Well surface is uniform, smooth and free from striation to eliminate error
- CV of transmittance is less than 5.00%
- Wells are labeled with alphanumeric code for easy identification
- DNase/RNase free and Non-pyrogenic
- Sterilized by irradiation SAL10⁻⁶ (ISO11137)
- Shelf life: 3 years after month of production
- Manufactured in a Class 100,000 cleanroom environment
- Manufactured under ISO13485 and ISO9001 quality management system

Description

96 Well, Fixed flat bottom, Sterile

Binding Capacity

High Binding

Purpose

ELISA Plates are optimal products for ELISA and provide reliable performance in binding assays when consistent coating of wells is required.

Materials

Strip: GPPS (General polystyrene)

Color: Clear

Dimensions (Unit: mm)

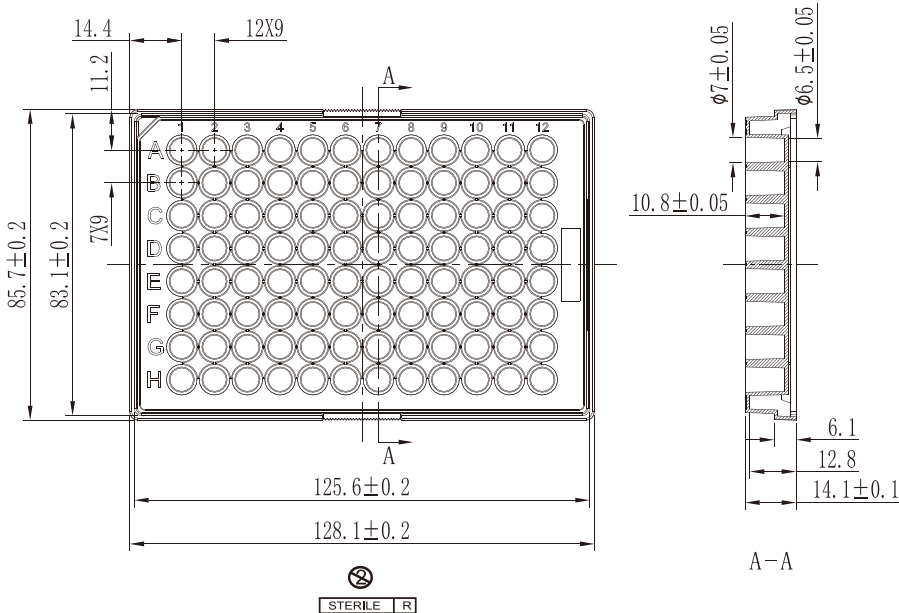

CELL CULTURE PLATE

6-well Cell Culture Plate

Cat No.	Size
PC306-0050	50 Plates/Case

Features

- High clarity, 100% virgin polystyrene
- Sterilized by E beam
- Vacuum Plasma tissue culture treatment
- Clear lot number for batch traceability
- Markings of well coordinates available for 6, 12, 24, 48 96 well plates
- Non Pyrogenic, DNase/RNase Free
- The package box of Simply® cell culture plates can be used as reservoirs

Cell Growth Area[cm²]: 9.5

Recommended Medium Volume[ml]: 1.9-2.9

Bottom: Flat

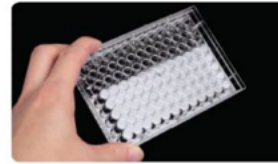

Excellent bottom uniformity



Special lid design low evaporation

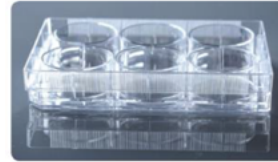

Frosted and noise-free bottom design for easy grip



Lot. No. for traceability

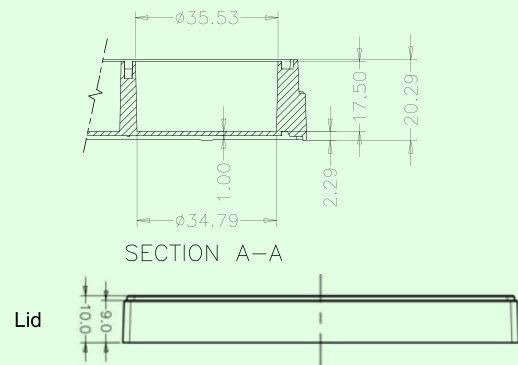
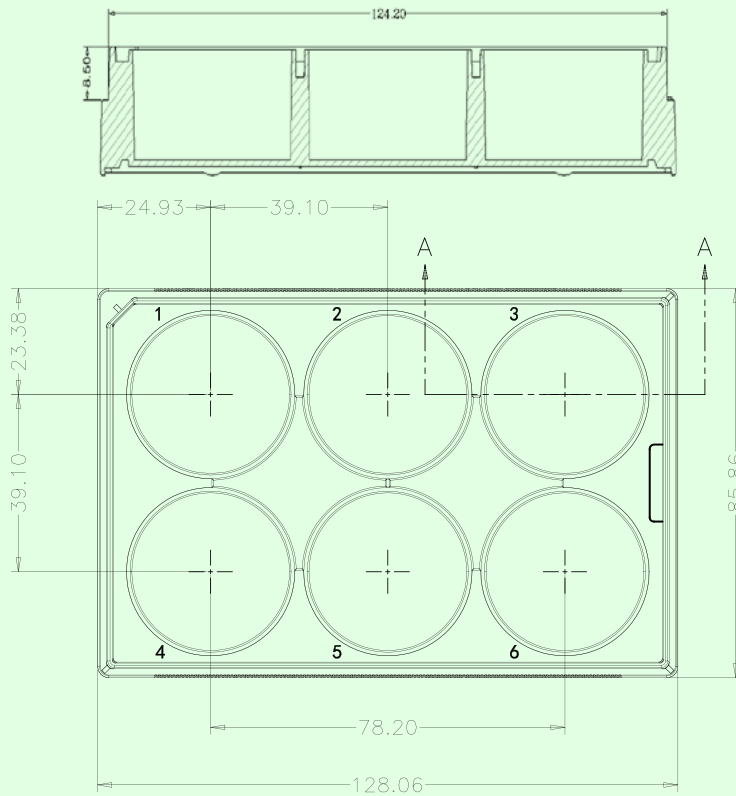

CELL CULTURE PLATE

12-well Cell Culture Plate

Cat No.	Size
PC312-0050	50 Plates/Case

Features

- High clarity, 100% virgin polystyrene
- Sterilized by E beam
- Vacuum Plasma tissue culture treatment
- Clear lot number for batch traceability
- Markings of well coordinates available for 6, 12, 24, 48 96 well plates
- Non Pyrogenic, DNase/RNase Free
- The package box of Simply® cell culture plates can be used as reservoirs

Cell Growth Area[cm²]: 3.6

Recommended Medium Volume[ml]: 0.76-1.14

Bottom: Flat

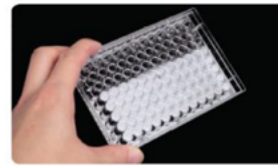

Excellent bottom uniformity



Special lid design low evaporation

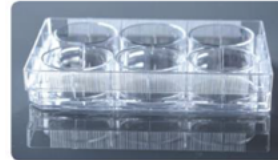

Frosted and noise-free bottom design for easy grip



Lot. No. for traceability

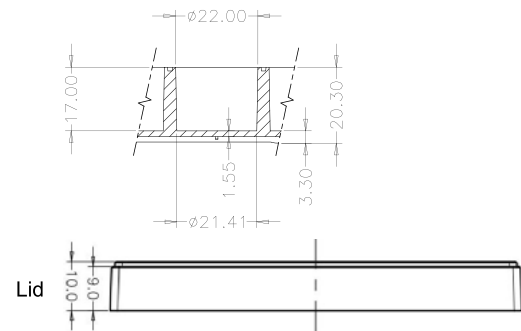
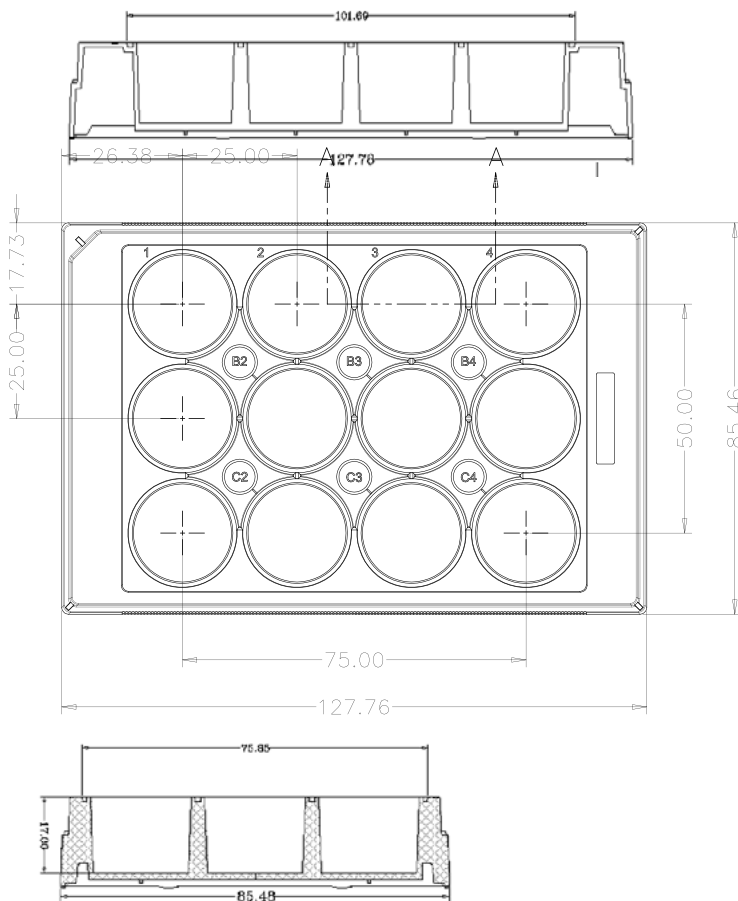

CELL CULTURE PLATE

24-well Cell Culture Plate

Cat No.	Size
PC324-0050	50 Plates/Case

Features

- High clarity, 100% virgin polystyrene
- Sterilized by E beam
- Vacuum Plasma tissue culture treatment
- Clear lot number for batch traceability
- Markings of well coordinates available for 6, 12, 24, 48 96 well plates
- Non Pyrogenic, DNase/RNase Free
- The package box of Simply® cell culture plates can be used as reservoirs

Cell Growth Area[cm²]: 1.9

Recommended Medium Volume[ml]: 0.38-0.57

Bottom: Flat

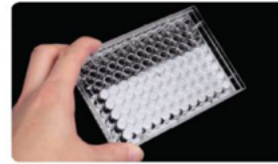

Excellent bottom uniformity



Special lid design low evaporation

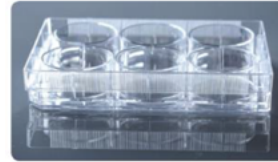

Frosted and noise-free bottom design for easy grip



Lot. No. for traceability

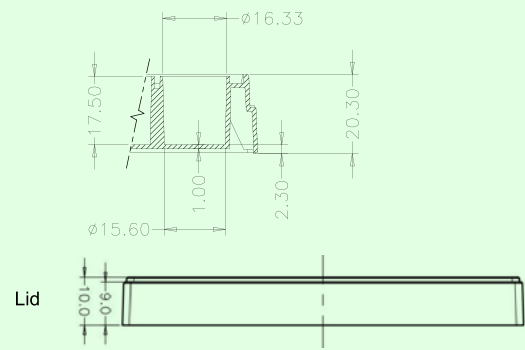
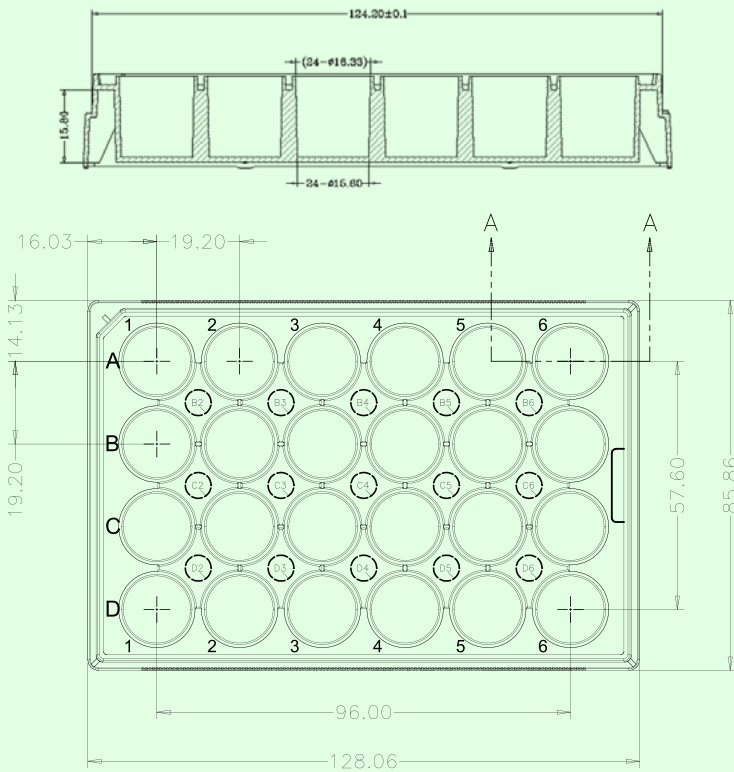

CELL CULTURE PLATE

48-well Cell Culture Plate

Cat No.	Size
PC348-0050	50 Plates/Case

Features

- High clarity, 100% virgin polystyrene
- Sterilized by E beam
- Vacuum Plasma tissue culture treatment
- Clear lot number for batch traceability
- Markings of well coordinates available for 6, 12, 24, 48 96 well plates
- Non Pyrogenic, DNase/RNase Free
- The package box of Simply® cell culture plates can be used as reservoirs

Cell Growth Area[cm²]: 0.88

Recommended Medium Volume[ml]: 0.19-0.285

Bottom: Flat

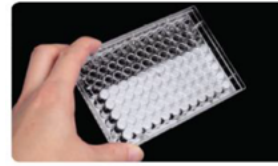

Excellent bottom uniformity



Special lid design low evaporation

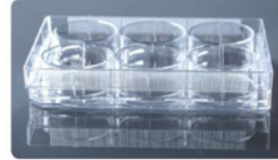

Frosted and noise-free bottom design for easy grip



Lot. No. for traceability

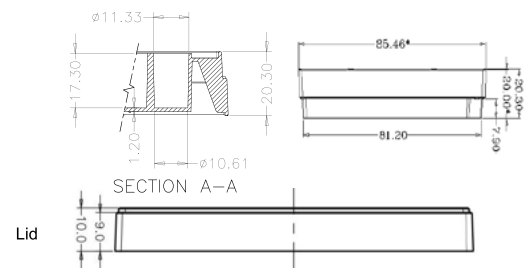
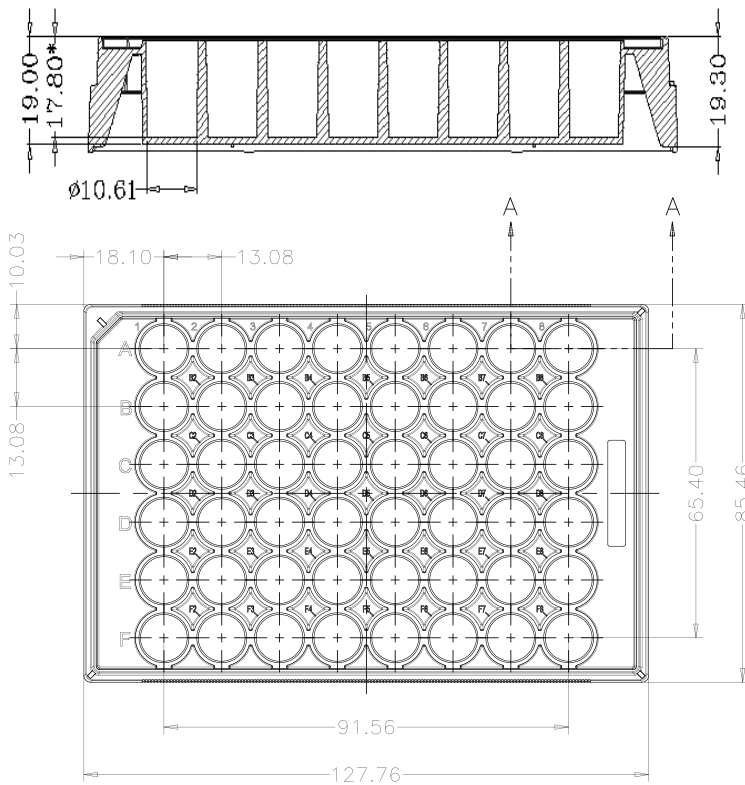

CELL CULTURE PLATE

96-well Cell Culture Plate

Cat No.	Size
PC396-0100	100 Plates/Case

Features

- High clarity, 100% virgin polystyrene
- Sterilized by E beam
- Vacuum Plasma tissue culture treatment
- Clear lot number for batch traceability
- Markings of well coordinates available for 6, 12, 24, 48 96 well plates
- Non Pyrogenic, DNase/RNase Free
- The package box of Simply® cell culture plates can be used as reservoirs

Cell Growth Area[cm²]: 0.32

Recommended Medium Volume[ml]: 0.1-0.2

Bottom: Flat

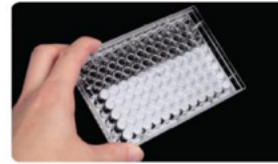

Excellent bottom uniformity



Special lid design low evaporation

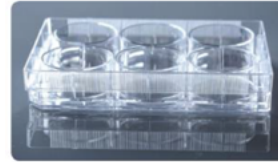

Frosted and noise-free bottom design for easy grip



Lot. No. for traceability

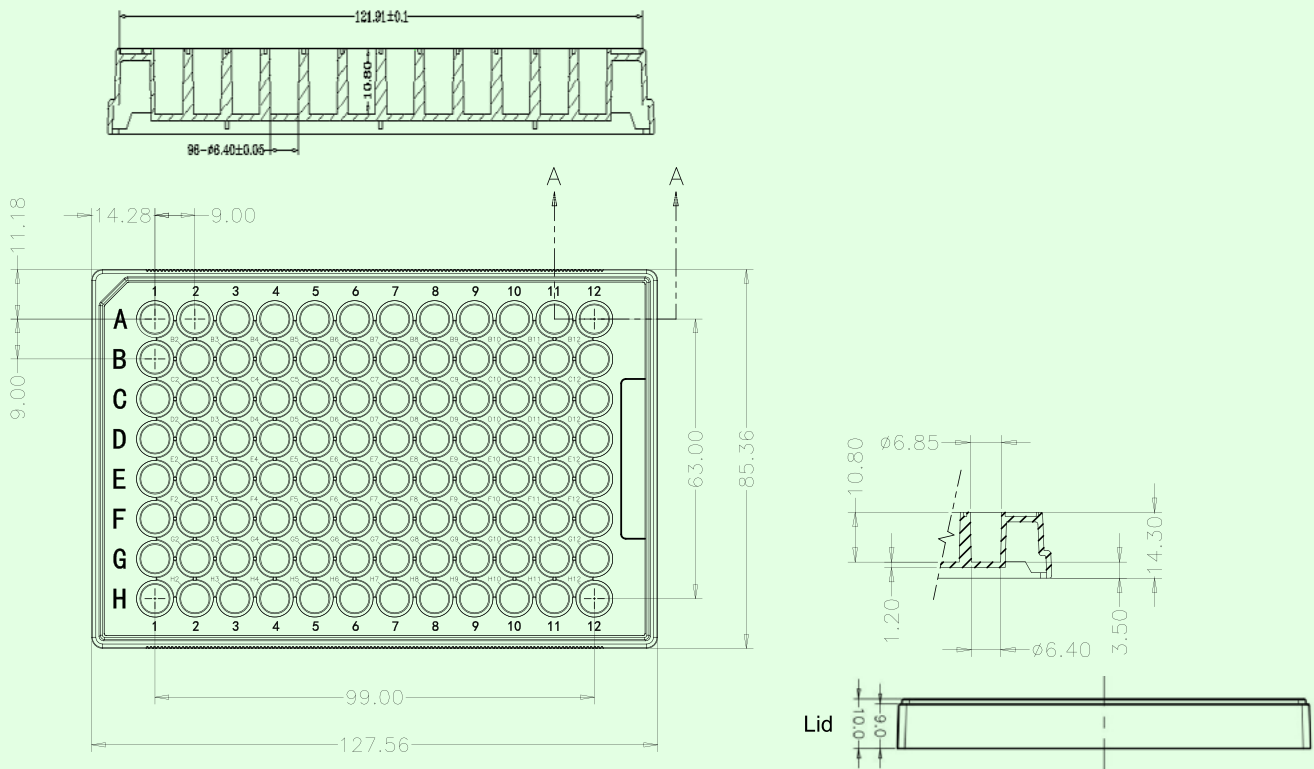

SEROLOGICAL PIPET

2 ml Serological Pipet

Cat No.	Size
PC502-0500	500 Pipets/Case

Features

- Temperature: -20°C to +50°C
- Sterilized by gamma irradiation SAL10⁻⁶(ISO11137)
- Latex Statement: this product is latex free
- DNase/RNase free, non-pyrogenic, non-cytotoxic
- Meet the requirements of BSE/TSE
- Use dispenser box for easy opening
- Available in Individually packed in peel-to-open wrap
- Autoclavability: No
- Negative graduations up to -0.6 ml (total volume = 2.6 ml)
- Graduation [ml]: in 1/50 ml
- Graduations are calibrated for accurate dispensing to within ±2%
- Color coded: green
- Shelf Life: 3 years after month of production
- Every product is printed with a batch number for traceability
- Manufactured in a class 100,000 room environment
- Manufactured under ISO13485 and ISO9001 quality management system

Description: 2 ml in 1/50 ml, Individually wrapped, paper / plastic

Sterile: Yes

Materials

Pipet: GPPS (General polystyrene), Compliance with USP Class VI
 Filter: PO (Polyolefin)
 Color: Clear

Purpose: Use for liquid transfer

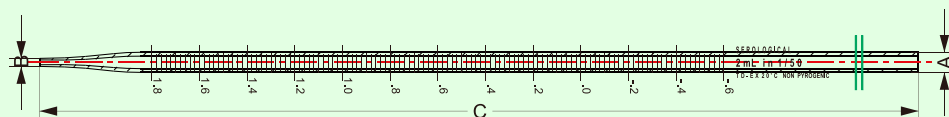

Unit: mm

	Dimensions	Tolerance
A	Ø6.3	±0.1
B	Ø2.93	±0.1
C	272.0	±0.1

5 ml Serological Pipet

Cat No.	Size
PC505-0200	200 Pipets/Case

Features

- Temperature: -20°C to +50°C
- Sterilized by gamma irradiation SAL10⁻⁶(ISO11137)
- Latex Statement: this product is latex free
- DNase/RNase free, non-pyrogenic, non-cytotoxic
- Meet the requirements of BSE/TSE
- Use dispenser box for easy opening
- Available in Individually packed in peel-to-open wrap
- Autoclavability: No
- Negative graduations up to -3 ml (total volume = 8 ml)
- Graduation [ml]: in 1/10 ml
- Graduations are calibrated for accurate dispensing to within ±2%
- Color coded: blue
- Shelf Life: 3 years after month of production
- Every product is printed with a batch number for traceability
- Manufactured in a class 100,000 room environment
- Manufactured under ISO13485 and ISO9001 quality management system

Description: 5 ml in 1/10 ml, Individually wrapped, paper / plastic

Sterile: Yes

Materials

Pipet: GPPS (General polystyrene), Compliance with USP Class VI
 Filter: PO (Polyolefin)
 Color: Clear

Purpose: Use for liquid transfer

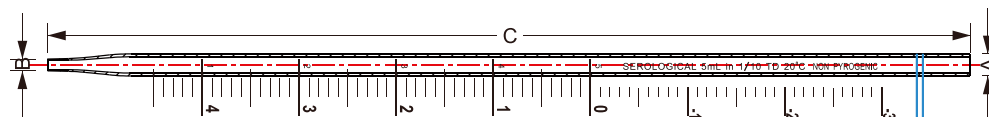

Unit: mm

	Dimensions	Tolerance
A	Ø8.2	±0.1
B	Ø2.5	±0.35
C	341.0	±2.0

SEROLOGICAL PIPET

10 ml Serological Pipet

Cat No.	Size
PC510-0200	200 Pipets/Case

Features

- Temperature: -20°C to +50°C
- Sterilized by gamma irradiation SAL10⁻⁶(ISO11137)
- Latex Statement: this product is latex free
- DNase/RNase free, non-pyrogenic, non-cytotoxic
- Meet the requirements of BSE/TSE
- Use dispenser box for easy opening
- Available in Individually packed in peel-to-open wrap
- Autoclavability: No
- Negative graduations up to -3 ml (total volume = 13 ml)
- Graduation [ml]: in 1/10 ml
- Graduations are calibrated for accurate dispensing to within ±2%
- Color coded: orange
- Shelf Life: 3 years after month of production
- Every product is printed with a batch number for traceability
- Manufactured in a class 100,000 room environment
- Manufactured under ISO13485 and ISO9001 quality management system

Description: 10 ml in 1/10 ml, Individually wrapped, paper / plastic

Sterile: Yes

Materials

Pipet: GPPS (General polystyrene), Compliance with USP Class VI
 Filter: PO (Polyolefin)
 Color: Clear

Purpose: Use for liquid transfer

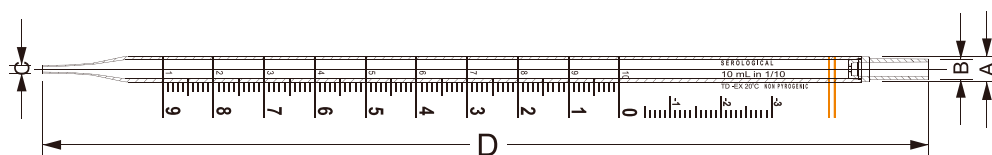

Unit: mm

	Dimensions	Tolerance
A	Ø10.96	±0.10
B	Ø7.95	±0.25
C	Ø2.95	±0.25
D	303.4	±2.0

25 ml Serological Pipet

Cat No.	Size
PC525-0150	150 Pipets/Case

Features

- Temperature: -20°C to +50°C
- Sterilized by gamma irradiation SAL10⁻⁶(ISO11137)
- Latex Statement: this product is latex free
- DNase/RNase free, non-pyrogenic, non-cytotoxic
- Meet the requirements of BSE/TSE
- Use dispenser box for easy opening
- Available in Individually packed in peel-to-open wrap
- Autoclavability: No
- Negative graduations up to -8 ml (total volume = 33 ml)
- Graduation [ml]: in 2/10 ml
- Graduations are calibrated for accurate dispensing to within ±2%
- Color coded: red
- Shelf Life: 3 years after month of production
- Every product is printed with a batch number for traceability
- Manufactured in a class 100,000 room environment
- Manufactured under ISO13485 and ISO9001 quality management system

Description: 25 ml in 2/10 ml, Individually wrapped, paper / plastic

Sterile: Yes

Materials

Pipet: GPPS (General polystyrene), Compliance with USP Class VI
 Filter: PO (Polyolefin)
 Color: Clear

Purpose: Use for liquid transfer

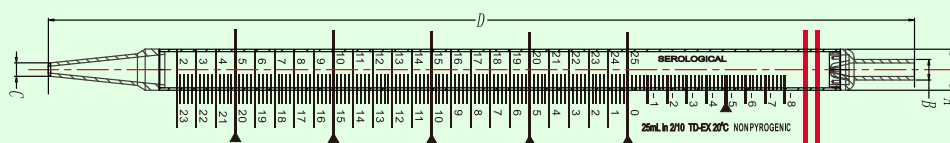

Unit: mm

	Dimensions	Tolerance
A	Ø15.1	±0.10
B	Ø7.95	±0.25
C	Ø5.0	±0.25
D	308.5	±2.0

SEROLOGICAL PIPET

50 ml Serological Pipet

Cat No.	Size
PC550-0100	100 Pipets/Case

Features

- Temperature: -20°C to +50°C
- Sterilized by gamma irradiation SAL1⁰⁻⁶(ISO11137)
- Latex Statement: this product is latex free
- DNase/RNase free, non-pyrogenic, non-cytotoxic
- Meet the requirements of BSE/TSE
- Use dispenser box for easy opening
- Available in Individually packed in peel-to-open wrap
- Autoclavability: No
- Negative graduations up to -10 ml (total volume = 60 ml)
- Graduation (ml): in 5/10 ml
- Graduations are calibrated for accurate dispensing to within ±2%
- Color coded: purple
- Shelf Life: 3 years after month of production
- Every product is printed with a batch number for traceability
- Manufactured in a class 100,000 room environment
- Manufactured under ISO13485 and ISO9001 quality management system

Description: 50 ml in 5/10 ml, Individually wrapped, paper / plastic

Sterile: Yes

Materials

Pipet: GPPS (General polystyrene), Compliance with USP Class VI
 Filter: PO (Polyolefin)
 Color: Clear

Purpose: Use for liquid transfer

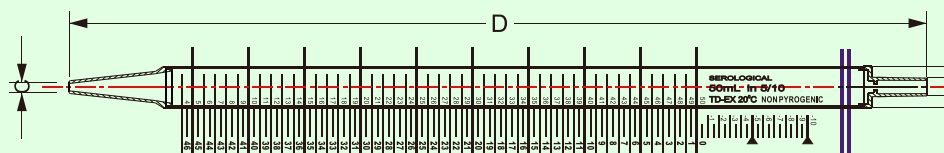

Unit: mm

	Dimensions	Tolerance
A	Ø18.4	±0.10
B	Ø8.0	±0.25
C	Ø5.8	±0.25
D	346.6	±2.0

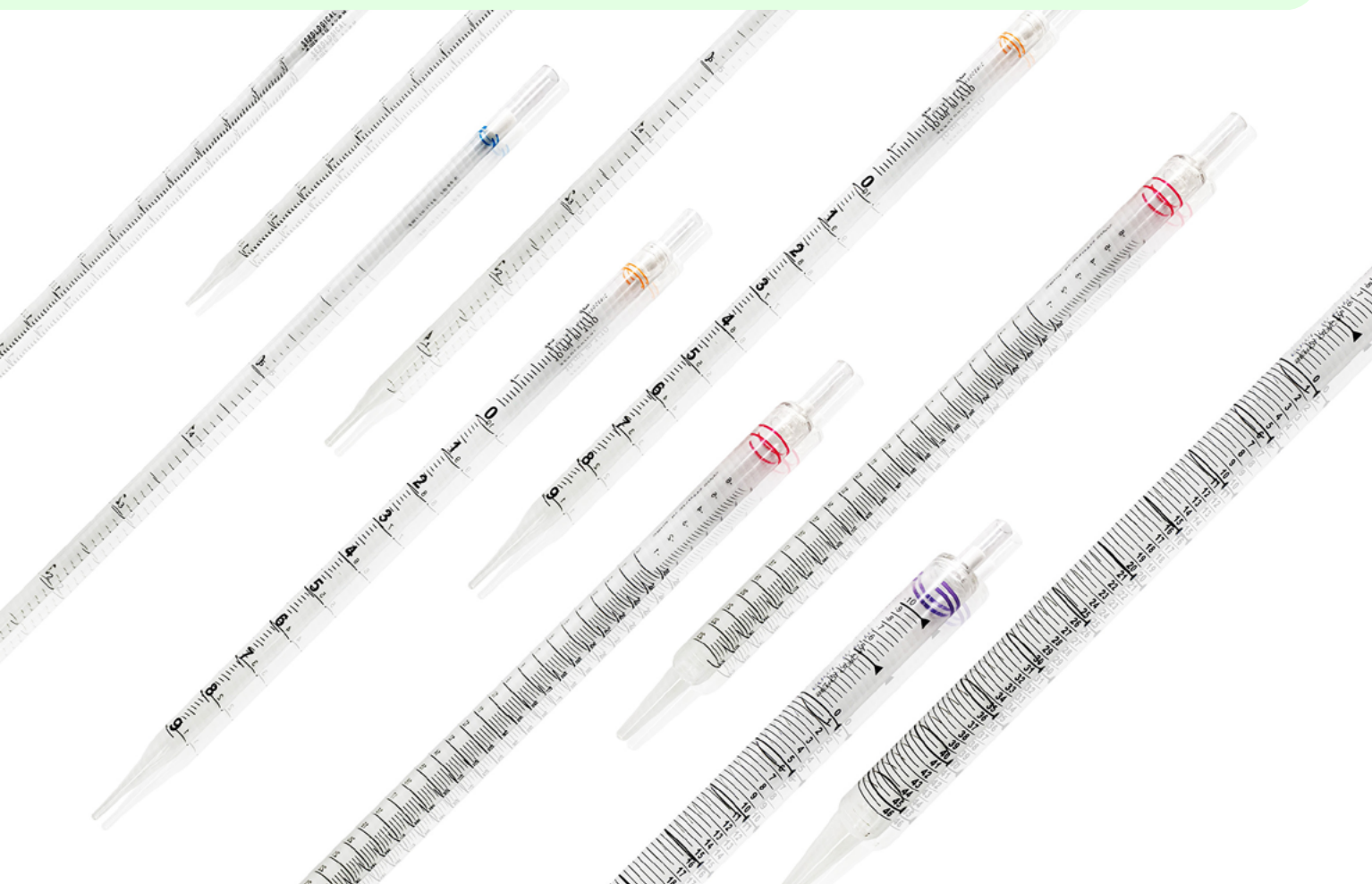

FILTER



PES Syringe Filter 33 mm, 22 µm

Cat No.	Size
PC601-0050	50 PCS/Case

Description

- Membrane: PES
- Diameter: 33mm
- Pore size: 0.22µm
- EO Gas sterilization
- Housing material: Polypropylene (PP)

Test	Specification
Hold-up volume	< 100 µl
Air leakage	No leak or visible bubbles during one minute at 3 Bar
Housing Burst Test	Burst pressure of ≥ 70 psi
Transmembrane Flow (ml/min. cm ² bar)	> 45
Bubble Point (water)	> 52 PSI

PVDF Syringe Filter 33 mm, 22 µm

Cat No.	Size
PC602-0050	50 PCS/Case

Description

- Membrane: PVDF
- Diameter: 33mm
- Pore size: 0.22µm
- EO Gas sterilization
- Housing material: Polypropylene (PP)

Test	Specification
Hold-up volume	< 100 µl
Air leakage	No leak or visible bubbles during one minute at 3 Bar
Housing Burst Test	Burst pressure of ≥ 70 psi
Water Flow Time (50cc water @ 30 kPa) Effective area 12.68 cm ²	33 -36 ml/min
Bubble Point (water)	400-410 kPa

Filter Cup 500 ml

Cat No.	Size
PC651-0024	1/Bag, 24/Case

Features

- Membrane type and pore size printed on unit
- Light weight and heavy wall construction
- Engraved graduation ensure veracity
- Designed hose connector can fit multiplicate hose diameters
- Effective filtration area of membrane: 38.04cm²
- Hold-up Volume after purge: <3mL

- DNase/RNase free and Non-pyrogenic
- Sterilized by irradiation SAL10⁻⁶ (ISO11137)
- Shelf Life: 3 years after month of production
- Manufactured in a class 100,000 room environment
- Manufactured under ISO13485 and ISO9001 quality management system

Description

500 mL Filter Upper Cup, Sterile

Purpose

Intended for the sterile vacuum filtration of aqueous solutions such as cell culture media and biological fluids

Materials

- Upper filter cup: Polystyrene (PS)
- Connector: Acrylonitrile-butadiene-styrene copolymer (ABS) and Polypropylene (PP)
- USP CLASS VI
 - Gamma irradiation Steriled 0.22 µm PES membrane, SAL 10⁻⁶
 - Membrane Diameter of 75 mm with the volume size of 500 ml
 - Good transparency, clear scale, easy to observe and read capacity
 - The upper cup has a GL-45 thread and fits most of glass and plastic mediastorage bottles
 - DNase/RNase-free, Non-pyrogenic
 - Sterilization: Yes
 - Pore size: 0.22 µm
 - Volume size: 500 ml
 - Qty. per bag/case: 1/24

Membrane Performance Characteristics

Pore size: 0.22 µm

Water flow rate (mL/min/cm² @ 0.7bar, 10psi): 19.3-34.6

Water bubble point (psi): 53.0-69.0

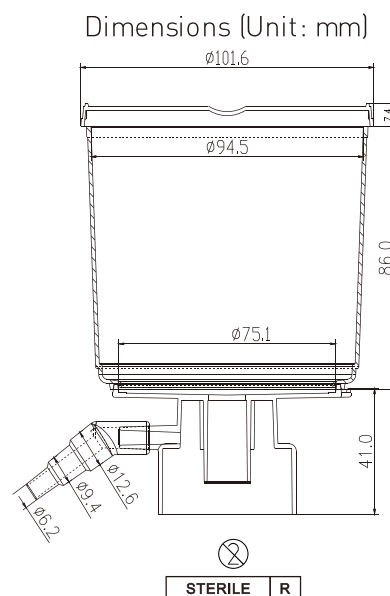

FILTER & CELL SCRAPE

Filter Cup 500 ml *R*TYPE

Cat No.	Size
PC652-0024	1/Bag, 24/Case

Features

- Membrane type and pore size printed on unit
- Light weight and heavy wall construction
- Engraved graduation ensure veracity
- Designed hose connector can fit multiplicate hose diameters
- Effective filtration area of membrane: 38.04cm²
- Hold-up Volume after purge: <3mL

Description

500 mL Filter Upper Cup, Sterile

Purpose

Intended for the sterile vacuum filtration of aqueous solutions such as cell culture media and biological fluids

Materials

- Upper filter cup: Polystyrene (PS)
- Connector: Acrylonitrile-butadiene-styrene copolymer (ABS) and Polypropylene (PP)
- USP CLASS VI
 - Gamma irradiation Steriled 0.22 μm PES *R*TYPE membrane, SAL 10⁻⁶
 - PES *R*TYPE membrane has faster filtration and a lower clogging rate
 - Membrane Diameter of 75 mm with the volume size of 500 ml
 - Good transparency, clear scale, easy to observe and read capacity
 - The upper cup has a GL-45 thread and fits most of glass and plastic media storage bottles
 - DNase/RNase-free, Non-pyrogenic
 - Sterilization: Yes
 - Pore size: 0.22 μm
 - Volume size: 500 ml
 - Qty. per bag/case: 1/24

- DNase/RNase free and Non-pyrogenic
- Sterilized by irradiation SAL10⁻⁶ (ISO11137)
- Shelf Life: 3 years after month of production
- Manufactured in a class 100,000 room environment
- Manufactured under ISO13485 and ISO9001 quality management system

Membrane Performance Characteristics

Pore size: 0.22 μm

Bubble point: ≥20 psi

Flow rate: Roll Average ≤115 sec/500 mL

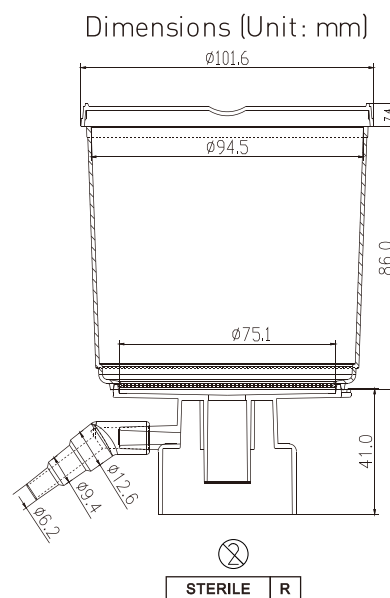

Cell Scraper

Name	Cat. No.	Size	Total Length	Blade Width
Cell Scraper 220mm, 13mm	PC722-0100	100 P/Box	220 mm	13 mm
Cell Scraper 280mm, 20mm	PC728-0100	100 P/Box	280 mm	20 mm

Simply® cell scrape can be used to scrap and collect cells easily and effectively. Push the handle with a slight pressure to change the blade angle. Then push down the handle towards the bottom of the container. Rotate the handle slightly to make the blade twist to right direction.

Features

- Blade is made of HIPS and handle is made of PP
- Free rotating blade, make the blade twist to right direction
- Easy-tear sterile packing

- Sterilized by E-beam, SAL=10⁻⁶
- Non-pyrogenic and DNase/RNase free

Description

Shelf Life: 3 Years after date of production
(ensure package is in good)

Application

blue handle & transparent blade

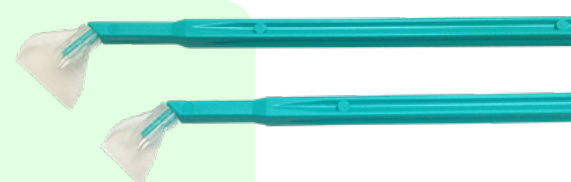

CUSTOM SERVICE

Product Name	Page
Dual Labeled Probe	114
PRIME Gene Synthesis & Subcloning	114
Custom Peptide Synthesis	114
Custom Antibody Production Service	115
Acro miR Vector System	115
Acro miR mimics & inhibitor System	116
Acro shRNA System	116
Acro siRNA System	116

CUSTOM SERVICE

Dual Labeled Probe

- We provide custom designed dual labeled probe set, including one probe and a pair of primers.
- Regular package: one vial of probe 5 OD (HPLC) with 5' FAM (reporter) and 3' TAMRA (quencher), and two vials of primers 2 OD each (PAGE).
- No extra charge for probe and primer design.
- BHQ: black hole quencher, one kind of nonfluorescent quencher.

Fluorescence	Excitation maximum (nm)	Emission maximum (nm)
FAM	490	525
JOE	520	548
Cy3	554	568
Cy5	649	666
ROX	575	602

Quencher	Absorption Max, nm	Quenching Range, nm
TAMRA	544	520-570
BHQ1	534	480-580
BHQ2	579	550-650
BHQ3	672	620-730

5'-FAM/3'-BHQ1	5'-FAM/3'-TAMRA
5'-JOE/3'-BHQ1	5'-JOE/3'-TAMRA
5'-ROX/3'-BHQ2	5'-Cy3/3'-BHQ2
5'-Cy5/3'-BHQ3	

PRIME Gene Synthesis & Subcloning

Custom Gene Synthesis Service — From DNA sequences to constructs with 100% accuracy guaranteed.

- We provide gene of interest into shuttle vector (pUC57, or other) of 2-4 µg lyophilized plasmid, sequencing data and QC reports
- Subcloning service: we can subclone the target gene sequence into your choice expression vector.
- We provide codon optimization for better protein yield.
- We provide library construction service including combinatorial variant libraries, CRISPR library, and NGS library probes.

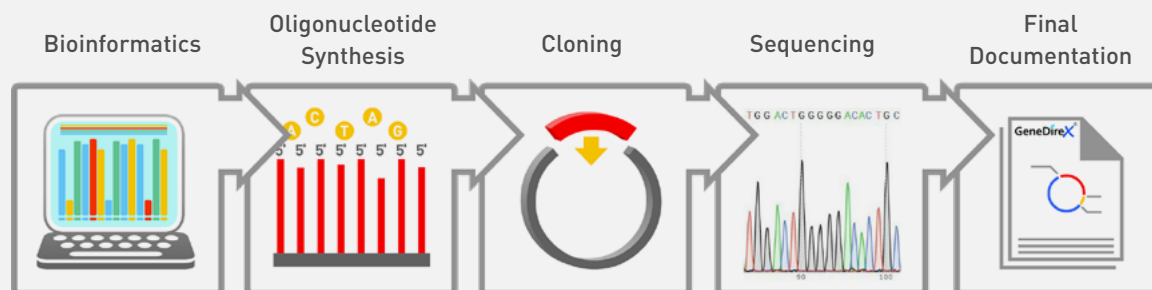

Custom Peptide Synthesis

- We can produce peptides from 3 to 100 AAs in length at purities from 80% up to 98%.
- Peptide quantity: 1-4 mg, 5-9 mg, 10 mg, 15 mg, 20 mg and other quantities.
- Research and cosmetic grade
- Modifications:

Fluorescent labeling	Biotin conjugation	Ahx linker or long carbon (LC) linker	BSA, KLH and OVA conjugation
FRET pairs	D form	Amidation and acetylation	Phosphorylation
Methylation	Disulfide bridge	Side chain modification	Cyclization

- custom peptide library service for screening including overlapping peptide library, alanine scanning library, truncation library, positional scanning library, random library and scrambled library.
- QC data: MS and HPLC analysis for each peptide
- Peptide solubility test
- Optional service:
 - Endotoxin test
 - TFA removal (salt form: acetate and hydrochloride)
 - Aliquoting service

CUSTOM SERVICE

Custom Antibody Production Service

We offer high quality custom antibody production services and professional antigen design. We provide professional affinity purification technique to increase the purity of antibodies.

Custom Rabbit Polyclonal Antibody

Reports and products

1. Control IgG antibody, 50 µg
2. Purified rabbit polyclonal antibody, 2-10 mg
3. QC report of antibody titration by ELISA, titer > 1:50,000

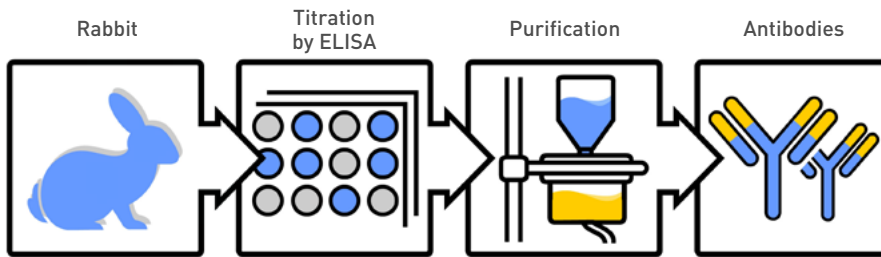

Custom Mouse Monoclonal Antibody

Reports and products

1. Two cryo-vials of hybridoma clones.
2. Each 5 mL supernatant from hybridoma culture media for each hybridoma clone.
3. QC report of antibody titration by ELISA

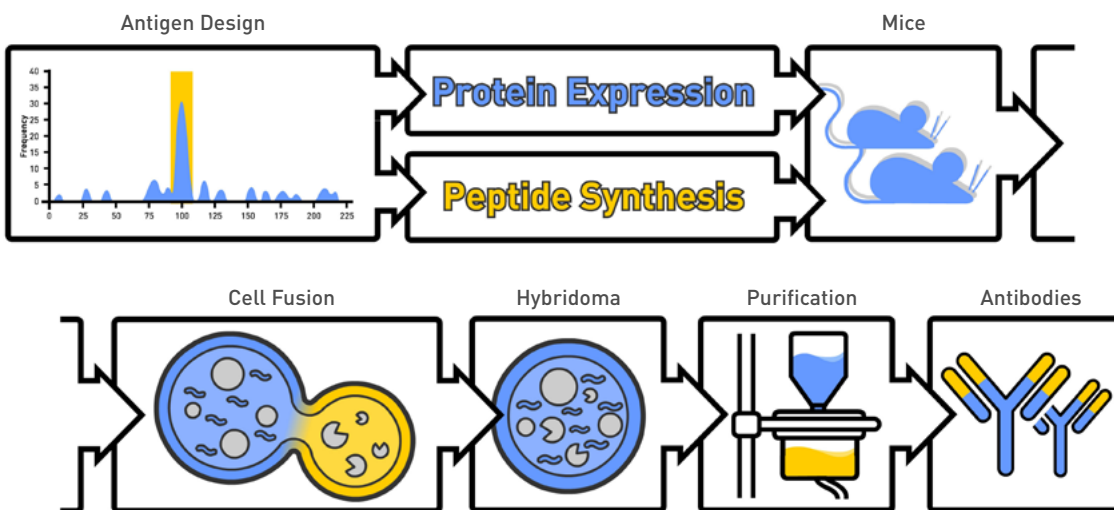

Acro miR Vector System

MicroRNA are typically 19 to 22 nucleotides long and are thought to regulate gene expression posttranscriptionally by binding to the 3' untranslated regions (UTRs) of target mRNAs and inhibiting their translation.

For constitutive microRNA expression, Acro miR vector construction is the best choice.

- We provide pre-miR, miR and miR inhibitor vector construction service.
- Latest version of miRBase sequence database version 22.1.
- Deliverable: One vial of 50µg for one miR vector construct.
- Delivery form: lyophilizing DNA powder

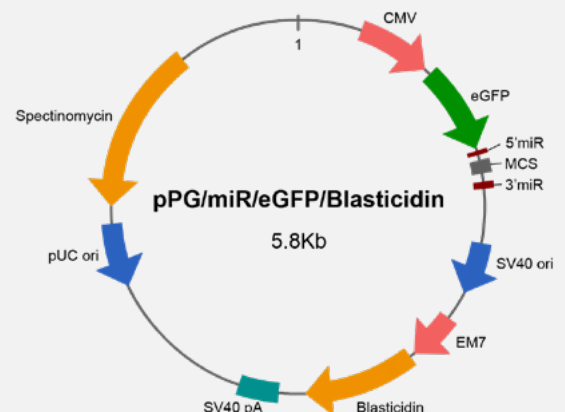

CUSTOM SERVICE

Acro miR mimics & inhibitor System

- We provide updated and comprehensive miR mimics and inhibitors for human, mouse, rat, and other species.
- Latest version of miRBase sequence database version 22.1.
- Regular package: One vial of 4 OD for double-stranded miR mimics or single-stranded miR inhibitors plus 1 OD of FAM-labeled universal negative control for free.
- High quality: HPLC purification.
- 2'OMe modification provides high stability.
- Modification: biotin, fluorescence-conjugation (FAM, Cy3, and Cy5) linker (5'-NH₂ or 3'-NH₂) and special labeling are available
- Special-modified Angomir and Antagomir are also available.
 - 2'OMe modification
 - Phosphorothioate oligonucleotides
 - Phosphorylation
 - 3' Cholesterol
 - 5' fluorescence conjugation is available.

Acro shRNA System

RNA interference (RNAi) is the most effective method to knock down gene expression with transfected siRNA. shRNAs are used in vector-based approaches for supplying siRNA to cells to produce stable gene silencing. We provide custom and pre-designed shRNA construct.

- Regular package: One vial of 50ug for one shRNA construct
- Regular set: Four vials of 50ug for each shRNA constructs of target gene plus one negative control for free.

shRNA set	Target gene	Universal N.C	Positive Control (GAPDH or β -actin)	Amount of shRNA
pGP system	4	1	1	6
pGLV system	4	1	NA	5

- Comprehensive vectors are available, including GFP, RFP and mCherry reporters and lentiviral backbone.
- Constitutive promoters are available (U6/H1).
- We provide custom shRNA design and siRNA to shRNA design.

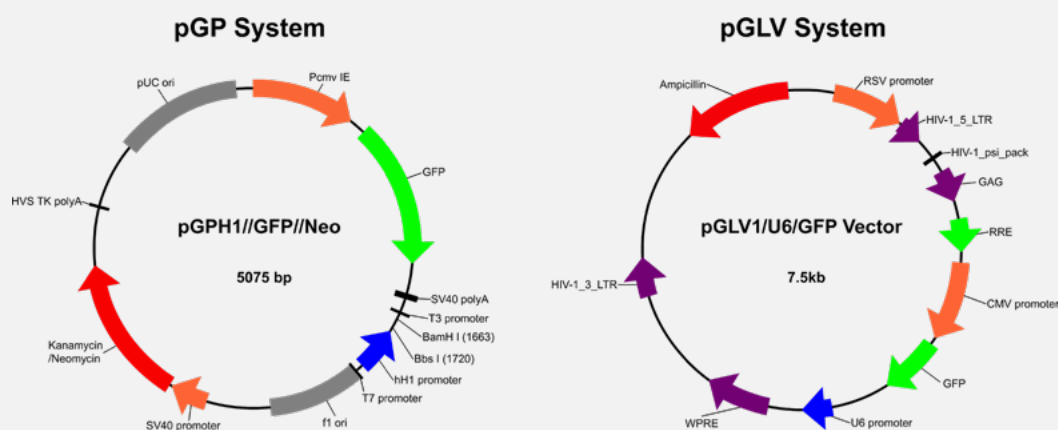

Acro siRNA System

RNA interference (RNAi) is the most effective method to knock down gene expression to study protein function. For transient silencing experiments, siRNAs are the best choice for this purpose.

- We provide custom and pre-designed siRNA duplex.
- Regular package: One vial of 4 OD for siRNA duplex plus 1 OD of FAM-labeled universal negative control for free.
- Regular set: Three vials of 2 OD for each siRNA duplex plus 1 OD of FAM-labeled universal negative control for free.
- High quality: HPLC purification.
- 2'OMe modification prolong siRNA half-life and provides high stability.
- Modification: Biotin, fluorescence-conjugation (FAM, Cy5, and Cy3), linker (5'-NH₂ or 3'-NH₂) and special labeling are available.
- Special custom modification is available.
- We provide siRNA design.

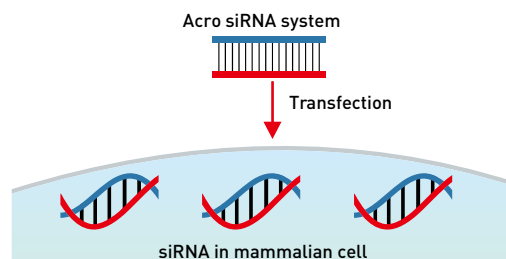

GeneDireX, Inc.

 www.genedirex.com  info@genedirex.com